

Mathematics 4C

Mathematics Department
Phillips Exeter Academy
Exeter, NH
August 2012

To the Student

Contents: Members of the PEA Mathematics Department have written the material in this book. As you work through it, you will discover that algebra, geometry, and trigonometry have been integrated into a mathematical whole. There is no Chapter 5, nor is there a section on tangents to circles. The curriculum is problem-centered, rather than topic-centered. Techniques and theorems will become apparent as you work through the problems, and you will need to keep appropriate notes for your records — there are no boxes containing important theorems. There is no index as such, but the reference section that starts on page 201 should help you recall the meanings of key words that are defined in the problems (where they usually appear italicized).

Comments on problem-solving: You should approach each problem as an exploration. Reading each question carefully is essential, especially since definitions, highlighted in italics, are routinely inserted into the problem texts. It is important to make accurate diagrams whenever appropriate. Useful strategies to keep in mind are: create an easier problem, guess and check, work backwards, and recall a similar problem. It is important that you work on each problem when assigned, since the questions you may have about a problem will likely motivate class discussion the next day.

Problem-solving requires persistence as much as it requires ingenuity. When you get stuck, or solve a problem incorrectly, back up and start over. Keep in mind that you're probably not the only one who is stuck, and that may even include your teacher. If you have taken the time to think about a problem, you should bring to class a written record of your efforts, not just a blank space in your notebook. The methods that you use to solve a problem, the corrections that you make in your approach, the means by which you test the validity of your solutions, and your ability to communicate ideas are just as important as getting the correct answer.

About technology: Many of the problems in this book require the use of technology (graphing calculators or computer software) in order to solve them. Moreover, you are encouraged to use technology to explore, and to formulate and test conjectures. Keep the following guidelines in mind: write before you calculate, so that you will have a clear record of what you have done; store intermediate answers in your calculator for later use in your solution; pay attention to the degree of accuracy requested; refer to your calculator's manual when needed; and be prepared to explain your method to your classmates. Also, if you are asked to “graph $y = (2x - 3)/(x + 1)$ ”, for instance, the expectation is that, although you might use your calculator to generate a picture of the curve, you should sketch that picture in your notebook or on the board, with correctly scaled axes.

Mathematics 4C

1. Consider the sequence defined recursively by $x_n = \sqrt{\sqrt{1996x_{n-1}}}$ and $x_0 = 1$. Calculate the first few terms of this sequence, and decide whether it approaches a *limiting value*.
2. In many states, automobile license plates display six characters — three letters followed by a three-digit number, as in SAS-311. Would this system work adequately in your state?
3. *Polar coordinates.* Given a point P in the xy -plane, a pair of numbers $(r; \theta)$ can be assigned, in which r is the distance from P to the origin O , and θ is the size of an angle in *standard position* that has OP as its terminal ray. Notice that there is more than one correct value for θ . Find polar coordinates for the following pairs (x, y) , giving at least two values of θ for each:
(a) $(0, 2)$ (b) $(-1, 1)$ (c) $(8, -6)$ (d) $(1, 7)$ (e) $(-1, -7)$
4. After being dropped from the top of a tall building, the height of an object is described by $y = 400 - 16t^2$, where y is measured in feet and t is measured in seconds.
(a) How many seconds did it take for the object to reach the ground, where $y = 0$?
(b) How high is the projectile when $t = 2$, and (approximately) how fast is it falling?
5. A potato is taken from the oven, its temperature having reached 350 degrees. After sitting on a plate in a 70-degree room for twelve minutes, its temperature has dropped to 250 degrees. In how many more minutes will the potato's temperature reach 120 degrees? Assume *Newton's Law of Cooling*, which says that the difference between an object's temperature and the ambient temperature is an exponential function of time.
6. Find coordinates x and y that are equivalent to polar coordinates $r = 8$ and $\theta = 112$.

7. *Spirals* are fundamental curves, but awkward to describe using only the Cartesian coordinates x and y . The example shown at right, on the other hand, is easily described with polar coordinates — all its points fit the equation $r = 2^{\theta/360}$ (using degree mode). Choose three specific points in the diagram and make calculations that confirm this. What range of θ -values does the graph represent? Show that the spiral can also be described by a pair of parametric equations $x = f(t)$ and $y = g(t)$. Use your graphing calculator (in both polar mode and parametric mode) to obtain pictures of this spiral.

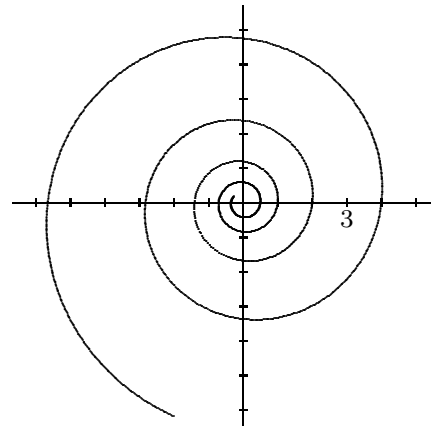

8. Find a function f for which $f(x + 3)$ is *not* equivalent to $f(x) + f(3)$. Then find an f for which $f(x + 3)$ *is* equivalent to $f(x) + f(3)$.
9. Draw a graph that displays plausibly how the temperature changes during a 48-hour period at a desert site. Assume that the air is still, the sky is cloudless, the Sun rises at 7 am and sets at 7 pm. Be prepared to explain the details of your graph.

Mathematics 4C

1. Before I can open my gym locker, I must remember the combination. Two of the numbers of this three-term sequence are 17 and 24, but I have forgotten the third, and do not know which is which. There are 40 possibilities for the third number. At ten seconds per try, at most how long will it take me to test every possibility? The answer is not 40 minutes!

2. Draw a picture of the spiral $r = 3^{\theta/720}$ in your notebook. Identify (and give coordinates for) at least four intercepts on each axis.

3. If $P(x) = 3(x + 1)(x - 2)(2x - 5)$, then what are the x -intercepts of the graph of $y = P(x)$? Find an example of an equation whose graph intercepts the x -axis only at -2 , $22/7$, and 8.

4. The x -intercepts of $y = f(x)$ are -1 , 3 , and 6 . Find the x -intercepts of
(a) $y = f(2x)$ **(b)** $y = 2f(x)$ **(c)** $y = f(x + 2)$ **(d)** $y = f(mx)$
 Compare the appearance of each graph to the appearance of the graph $y = f(x)$.

5. Some functions f have the property that $f(-x) = f(x)$ for all values of x . Such a function is called *even*. What does this property tell us about the appearance of the graph of $y = f(x)$? Show that $C(x) = \frac{1}{2}(2^x + 2^{-x})$ is an even function. Give other examples.

6. Let the focal point F be at the origin, the horizontal line $y = -2$ be the directrix, and $P = (r; \theta)$ be equidistant from the focus and the directrix. Using the polar variables r and θ , write an equation that says that the distance from P to the directrix equals the distance from P to F . The configuration of all such P is a familiar curve; make a rough sketch of it. Then rearrange your equation so that it becomes $r = \frac{2}{1 - \sin \theta}$, put your calculator into polar mode, and graph this familiar curve. On which polar ray does no point appear?

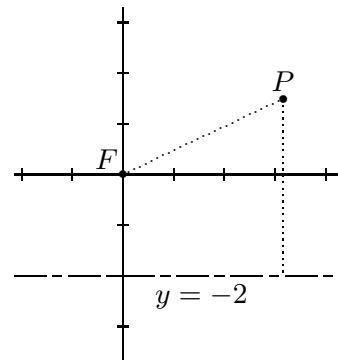

7. Let $f(x) = \sqrt{\sqrt{1996x}}$. On the same coordinate-axis system, graph both $y = f(x)$ and $y = x$. What is the significance of the first-quadrant point where the graphs intersect?

8. The sequence defined recursively by $x_n = \sqrt{\sqrt{1996x_{n-1}}}$ and $x_0 = 1$ approaches a limiting value as n grows infinitely large. Would this be true if a different value were assigned to x_0 ?

9. After being thrown from the top of a tall building, a projectile follows a path described parametrically by $(x, y) = (48t, 400 - 16t^2)$, where x and y are in feet and t is in seconds.
(a) How many seconds did it take for the object to reach the ground, where $y = 0$? How far from the building did the projectile land?
(b) How fast was the projectile moving at $t = 0$ when it was thrown?
(c) Where was the projectile when $t = 2$, and (approximately) how fast was it moving?

Mathematics 4C

1. What single word describes functions f that have the property $f(x + 6) = f(x)$ for all values of x ? Name two such functions. What geometric symmetry does such a graph $y = f(x)$ have?

2. The shape assumed by a hanging chain looks suspiciously like a parabola. Extract data from the figure at right and test this hypothesis. The graph paper has been positioned so that the chain is suspended at the points $(4, 7)$ and $(-4, 7)$, with the lowest point on the chain sitting at the origin.

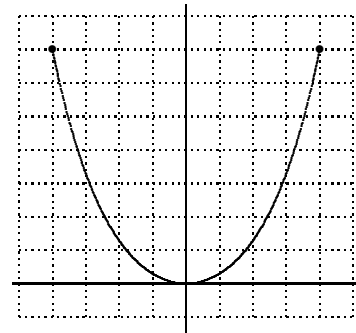

3. Garbanzo bean cans usually hold 4000 cc (4 liters). It seems likely that the manufacturers of these cans have chosen the dimensions so that the material required to enclose 4000 cc is as small as possible. Let's find out what the optimal dimensions are.

(a) Find an example of a right circular cylinder whose volume is 4000. Calculate the total surface area of your cylinder, in square cm.

(b) Express the height and surface area of such a cylinder as a function of its radius r .

(c) Find the value of r that gives a cylinder of volume 4000 the smallest total surface area that it can have, and calculate the resulting height.

4. (Continuation) Graph the functions $f(x) = 2\pi x^2$ and $g(x) = \frac{8000}{x}$, using the graphing window $-30 < x < 30$, $-2000 < y < 3000$. In the same window, graph $f + g$, and explain whatever asymptotic behavior you see.

5. Simplify without resorting to a calculator:

(a) $\sin(\sin^{-1} x)$ (b) $10^{\log y}$ (c) $F(F^{-1}(y))$ (d) $F^{-1}(F(x))$

6. Many sequences are defined by applying a function f repeatedly, using the recursive scheme $x_n = f(x_{n-1})$. The long-term behavior of such a sequence can be visualized by building a *web diagram* on the graph of $y = f(x)$. To set up stage 0 of the recursion, add the line $y = x$ to the diagram, and mark the point (x_0, x_0) on it. Stage 1 is reached by adding two segments — from (x_0, x_0) to (x_0, x_1) , and from (x_0, x_1) to (x_1, x_1) . In general, stage n is reached from stage $n - 1$ by adding two segments — from (x_{n-1}, x_{n-1}) to (x_{n-1}, x_n) , and from (x_{n-1}, x_n) to (x_n, x_n) . Identify the parts of the example shown at right. Then draw the first stages of a new web diagram — the one associated with the function $f(x) = (1996x)^{1/4}$ and the *seed value* $x_0 = 1$.

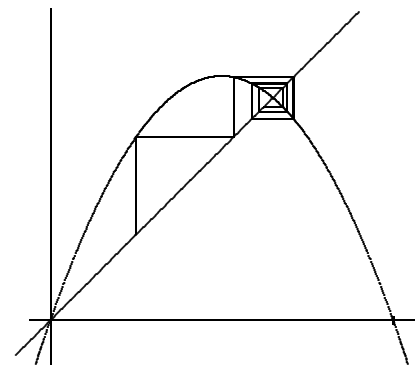

7. It is true that $(5/6)^n < 0.0001$ for all sufficiently large values of n . How large is “sufficiently large”?

8. *What “limit” means.* If p is any small positive number, then $(5/6)^n < p$ is true for all sufficiently large values of n . How large is “sufficiently large”? It is customary to summarize this situation by writing $\lim_{n \rightarrow \infty} (5/6)^n = 0$.

Mathematics 4C

1. Some functions f have the property that $f(-x) = -f(x)$ for all values of x . Such a function is called *odd*. What does this property tell us about the appearance of the graph of $y = f(x)$? Show that $S(x) = \frac{1}{2}(2^x - 2^{-x})$ is an odd function. Give other examples.
2. Many quadratic equations have no real solutions. The simplest example is $x^2 + 1 = 0$. Rather than continuing to ignore such problems, let us do something about them. The traditional approach is to let i stand for a number that has the property $i^2 = -1$. The solutions to $x^2 + 1 = 0$ are therefore $x = i$ and $x = -i$, and the solutions to $x^2 - 4x + 5 = 0$ are $x = 2 + i$ and $x = 2 - i$. By completing the square, find the solutions to $x^2 - 6x + 13 = 0$, expressing them in the same $a + bi$ form.
3. (Continuation) Numbers of the form $a + bi$, in which a and b are real, are called *complex numbers*. They are often called *imaginary numbers*, but this is inaccurate, for ordinary real numbers are included among them (for example, 3 is the same as $3 + 0i$). Strictly speaking, the number i is called the *imaginary unit*, and bi is called *pure imaginary* whenever b is a nonzero real number.

Whatever these numbers may represent, it is important to be able to visualize them. Here is how to do it: The number $a + bi$ is matched with the point (a, b) , or with the vector $[a, b]$ that points from the origin to (a, b) . Points $(0, y)$ on the y -axis are thereby matched with pure imaginary numbers $0 + yi$, so the y -axis is sometimes called the *imaginary axis*. The x -axis is called the *real axis* because its points $(x, 0)$ are matched with real numbers $x + 0i$. The real-number line can thus be thought of as a subset of the *complex-number plane*. Plot the following complex numbers: $1 + i$, $-5i$, and $1 + i\sqrt{3}$.

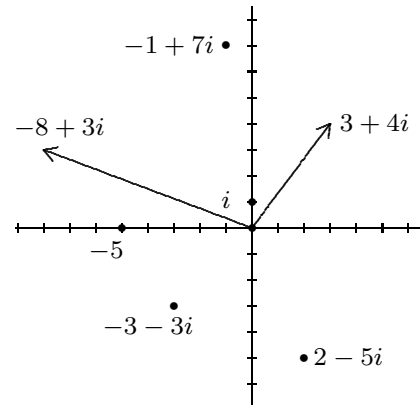

4. Because complex numbers have two components, which are usually referred to as x and y , it is traditional to use another letter to name complex numbers, as in $z = x + yi$. The components of $z = x + yi$ are usually called the *real part of z* and the *imaginary part of z* . Notice that i is not included in the imaginary part; for example, the imaginary part of $3 - 4i$ is -4 . Thus the imaginary part of a complex number is a real number. What do we call a complex number whose imaginary part is 0? What do we call a complex number whose real part is 0? Describe the configuration of complex numbers whose real parts are all 2. Describe the configuration of complex numbers whose real and imaginary parts are the same.
5. Because complex numbers are identified with vectors in the plane, it makes sense to talk about their *magnitudes*. Calculate (a) $|3 + 4i|$ (b) $|i|$ (c) $|3 - 2i|$ (d) $|3 + 2i|$
6. Given that function f has the property $f(180 - x) = f(x)$ for all x -values, show that the graph $y = f(x)$ has reflective symmetry. Identify the mirror. Name two such functions.

Mathematics 4C

1. Let F be the focal point $(0, 0)$, the horizontal line $y = -12$ be the directrix, and P be a generic point in the plane. Using the polar variables r and θ , write an equation that says that the distance from P to F is half the distance from P to the directrix. For example, you should find that the coordinates $r = 4.8$ and $\theta = 210$ degrees describe such a P . The configuration of all such points P is a familiar curve. After you make a rough sketch of it, put your calculator into polar mode and graph this equation. (First rearrange your equation so that r is expressed as a function of θ .) What type of curve is this?

2. (Continuation) Find a Cartesian equation. Calculate a , b , c , and the eccentricity c/a .

3. Part of the graph of $y = f(x)$ is shown at right. Draw the rest of the figure, given the additional information that (a) f is an even function; (b) f is an odd function.

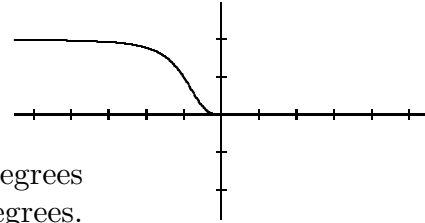

4. A Butterball® turkey whose core temperature is 70 degrees is placed in an oven that has been preheated to 325 degrees.

After one hour, the core temperature has risen to 100 degrees. The turkey will be ready to serve when its core temperature reaches 190 degrees. To the nearest minute, how much more time will this take?

5. Describe the configuration of complex numbers whose magnitude is 5. Give examples.

6. Perform the following arithmetic calculations, remembering the unusual fact $i^2 = -1$. Put your answers into the standard $a + bi$ form. Draw a diagram for each part.

(a) add $3 - i$ and $2 + 3i$ (b) multiply $3 + 4i$ by i (c) multiply $3 + i$ by itself
How does your answer to part (a) relate to the vector nature of complex numbers?

7. Suppose that $f(2 + u) = f(2 - u)$ holds for all values of u . What does this tell you about the graph of $y = f(x)$?

8. Starting at the origin, a bug jumps randomly along a number line. Each second it jumps either one unit to the right or one unit to the left, either move being equally likely. This is called a *one-dimensional random walk*. What is the probability that,

(a) after eight jumps, the bug has returned to the point of departure?
(b) after eight jumps, the bug will be within three units of the point of departure?

9. The useful abbreviation $\text{cis } \theta$ stands for the complex number $\cos \theta + i \sin \theta$. Where have you seen cosine and sine combined in this way before? Explain the abbreviation *cis*, then show that each of the following can be written in the form $\text{cis } \theta$:

(a) $0.6 + 0.8i$ (b) $-\frac{1}{2} + \frac{\sqrt{3}}{2}i$ (c) $0.28 + 0.96i$

10. (Continuation) A complex number can be expressed in *rectangular form*, which means $a + bi$, or in *polar form*, which means $r \text{cis } \theta$. Working in degree mode, find the rectangular form that is equivalent to $2 \text{cis } 72$. Find the polar form that is equivalent to $3 + 4i$.

Mathematics 4C

1. You have recently studied the statements $f(-x) = f(x)$, $f(180 - x) = f(x)$, and $f(-x) = -f(x)$, each of which is called an *identity*. When such a statement is true for all values of x , the function f is said to “satisfy the identity.” Each of the identities above is a concise way to describe a symmetry of a graph $y = f(x)$. Write an identity that says that the graph $y = f(x)$ **(a)** has period 72; **(b)** has reflective symmetry in the line $x = 72$.
2. Write $x^2 - 4$ as a product of linear factors. Now do the same for $x^2 + 4$.
3. Two numbers, x and y , are randomly chosen between 0 and 1. (Your calculator has a random-number generator.) What is the probability that $x + y$ will be less than 1?
4. Does the graph of $y = x^3 - x$ have half-turn symmetry at the origin? Explain.
5. Given $f(x) = \sqrt{x}$ and $g(x) = x^2 + 9$, find:
(a) $f(x - 1)$ **(b)** $g(2x)$ **(c)** $f(g(5))$ **(d)** $g(f(5))$ **(e)** $f(g(x))$
6. Find functions p and q that show that $p(q(x))$ can be equivalent to $q(p(x))$.
7. In Dilcue, ND, the fire and police departments hold fund-raising raffles each year. This year, the fire department is giving away a \$250 cash prize and has printed 1000 tickets and the police department is giving away a \$100 prize and has printed 500 tickets. All tickets cost the same amount and you can afford only one. Which raffle will you play, and why?
8. Consider the recursive formula $x_n = x_{n-1} + 1.25(1 - x_{n-1}) \cdot x_{n-1}$. Find the long-term behavior of this sequence for each of the following initial values:
(a) $x_0 = 0.2$ **(b)** $x_0 = -0.001$ **(c)** $x_0 = 0.999$ **(d)** $x_0 = 1.2$ **(e)** $x_0 = 1.801$
Does the long-term behavior depend on the value of x_0 ?
9. It is evident that $s(x) = \sin(2x)$ is expressed in the form $p(q(x))$. It is customary to say that s is a *composite* of functions p and q . Notice that s is periodic. Is $q(p(x))$?
10. (Continuation) A natural question here is whether a composite of two functions is *guaranteed* to be periodic whenever one of the two constituent functions is periodic. As you explore this question, consider the composites formed from $g(x) = 2^x$ and $h(x) = \sin x$.
11. Draw the spiral $r = 3^{\theta/360}$, for $-420 \leq \theta \leq 210$. Pick a point P on the spiral that no one else in the class will think of. Using a point on the spiral that is very close to your P , calculate a good approximate value for the slope of the tangent line at P . Calculate the size of the acute angle formed by this tangent line and the ray that goes from the origin through P . It might seem silly to compare answers to this question with your neighbor, but there is a reason to do so.
12. What is $i^{1234567890}$?

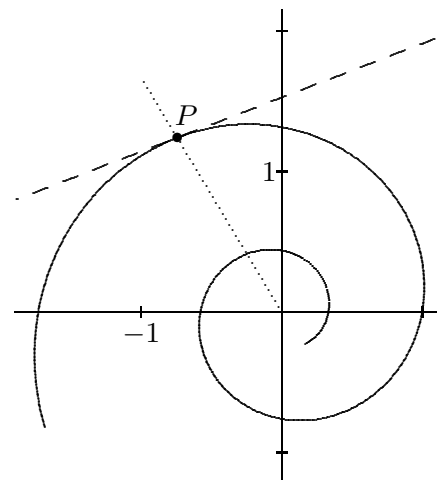

Mathematics 4C

1. When two six-sided dice both land showing ones, it is called *snake-eyes*. What is the probability of this happening? What is the most likely sum of two dice?
2. If three dice are tossed, their sum could be 7. What is the probability of this really happening, however?
3. Find a function f for which $f(x)f(a) = f(x+a)$ for all numbers x and a .
4. Write an identity that says that the graph of $y = f(x)$
(a) has reflective symmetry in the line $x = 40$ (b) has half-turn symmetry at $(40, 0)$
5. When you formulate your answer to the following, it will help to regard $a + bi$ as a vector: What is the effect of multiplying an arbitrary complex number $a + bi$ by i ?
6. Verify that $\left| \frac{2^n - 1}{2^n + 1} - 1 \right| < 0.0001$ for all sufficiently large values of n . In other words, how large is “sufficiently large”?
7. What “limit” means. If p is any small positive number, then $\left| \frac{2^n - 1}{2^n + 1} - 1 \right| < p$ is true for all sufficiently large values of n . How large is “sufficiently large”? It is customary to summarize this situation by writing $\lim_{n \rightarrow \infty} \frac{2^n - 1}{2^n + 1} = 1$.
8. Which is best, to have money in a bank that pays 9 percent annual interest, one that pays 9/12 percent monthly interest, or one that pays 9/365 percent daily interest? A bank is said to *compound* its annual interest when it applies its annual interest rate to payment periods that are shorter than a year.
9. (Continuation) Inflation in the country of Syldavia has reached alarming levels. Many banks are paying 100 percent annual interest, some banks are paying 100/12 percent monthly interest, a few are paying 100/365 percent daily interest, and so forth. Trying to make sense of all these promotions, Milou decides to graph the function E defined by $E(x) = \left(1 + \frac{1}{x}\right)^x$. What does this graph reveal about the sequence $v_n = \left(1 + \frac{1}{n}\right)^n$? Calculate the specific values v_1 , v_{12} , v_{365} , and $v_{31536000}$.
10. (Continuation) This sequence has a *limiting value*. This example is so important that a special letter is reserved for the limiting value (as is done for π). It is now traditional to write $e = \lim_{n \rightarrow \infty} \left(1 + \frac{1}{n}\right)^n$, which means that $\left(1 + \frac{1}{n}\right)^n$ approaches e as n approaches infinity. This limit is an example of an *indeterminate form*. For some additional limit practice, use your calculator to evaluate $\lim_{n \rightarrow \infty} \left(1 + \frac{0.09}{n}\right)^n$, which is greater than 1. Make up a story to go with this question.
11. You have seen some examples of sequences that approach limiting values. Evaluate each of the following. Notice that (b) concerns the partial sums of a geometric series.
(a) $\lim_{n \rightarrow \infty} \frac{1}{n}$ (b) $\lim_{n \rightarrow \infty} \frac{1 - (0.97)^n}{1 - 0.97}$ (c) $\lim_{n \rightarrow -\infty} \frac{2^n - 1}{2^n + 1}$

Mathematics 4C

1. Show that the product of the two non-real numbers $3 + 2i$ and $3 - 2i$ is a positive real number. Assuming that a and b are real numbers, explain why the product $(a + bi)(a - bi)$ is always a nonnegative real number.
2. Expand $(x + x^{-1})^7$ as a sum of powers of x . What information does the answer reveal about 7-step random walks?
3. In the *Tri-State Megabucks Lottery*, a player chooses six different numbers from 1 to 40, hoping to match all six numbers to be randomly drawn that week. The order in which the numbers are drawn is unimportant. What is the probability of winning this lottery?
4. (Continuation) The jackpot is ten million dollars (ten *megabucks*). A fair price to pay for a ticket is its *expected value*. Why? Calculate this value, which is more than \$2. Assume that there is a unique winner (the winning ticket was sold only once).
5. Given a function f , each solution to the equation $f(x) = 0$ is called a *zero* of f . Without using a calculator, find the zeros of the following:
(a) $s(x) = \sin 3x$ (b) $L(x) = \log_5(x - 3)$ (c) $r(x) = \sqrt{2x + 5}$ (d) $p(x) = x^3 - 4x$
6. The zeros of the function Q are -4 , 5 , and 8 . Find the zeros of the functions
(a) $f(x) = Q(4x)$ (b) $p(x) = -2Q(x)$ (c) $t(x) = Q(x - 3)$
(d) $j(x) = Q(2x/5)$ (e) $k(x) = Q(2x - 3)$
7. Pat and Kim are each in the habit of taking a morning coffee break in Grill. Each arrives at a random time between 9 am and 10 am, and stays for exactly ten minutes. What is the probability that Pat and Kim will see each other tomorrow during their breaks?
8. Find the angle formed by the complex numbers $3 + 4i$ and $-5 + 12i$ (drawn as vectors placed tail to tail).
9. For what value of x does the infinite geometric series $1 + x + x^2 + x^3 + \dots$ have $2/3$ as its sum? For this value of x , it is customary to say that the series *converges* to $2/3$. Is it possible to find a value for x that makes the series converge to $1/5$?
10. Working in radian mode, verify that $|\arctan(x) - \frac{1}{2}\pi| < 0.0001$ for all sufficiently large values of x . In other words, how large is “sufficiently large”?
11. *What “limit” means.* If p is any small positive number, then $|\arctan(x) - \frac{1}{2}\pi| < p$ is true for all sufficiently large positive values of x . How large is “sufficiently large”? It is customary to summarize this situation by writing $\lim_{x \rightarrow \infty} \arctan x = \frac{1}{2}\pi$.
12. Find a function f for which $f(x/a) = f(x) - f(a)$ for all positive numbers x and a .
13. If h is a number that is close to 0, the ratio $\frac{2^h - 1}{h}$ is close to $0.693 \dots$. Express this using limit notation. Interpret the answer by using a *secant line* for the graph of $y = 2^x$. Notice that this limit provides another example of an *indeterminate form*.

Mathematics 4C

1. A basket contains three green apples and six red apples. Three of the apples are selected at random. What is the probability that all three will be green? To make this probability smaller than 0.1%, how many red apples must be added to the basket?

2. You are familiar with Cartesian graph paper (see the illustration at right), which is useful for problems expressed in Cartesian coordinates. Draw what you think a sheet of *polar graph paper* would look like.

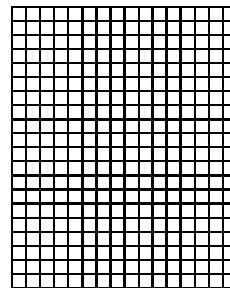

3. The *arithmetic mean* of two numbers p and q is $\frac{1}{2}(p + q)$. The *geometric mean* of two positive numbers p and q is \sqrt{pq} . Explain the meanings of these terms. You will probably need to make reference to arithmetic and geometric sequences in your explanation.

4. Write $3 + 4i$ and $1 + i$ in polar form. Then calculate the product of $3 + 4i$ and $1 + i$, and write this complex number in polar form as well. Do you notice anything remarkable?

5. *The Babylonian algorithm.* Calculate a few terms of the sequence defined by the seed value $x_0 = 1$ and the recursion $x_n = \frac{1}{2}\left(x_{n-1} + \frac{5}{x_{n-1}}\right)$. Find $\lim_{n \rightarrow \infty} x_n$, and thereby discover what this sequence was designed to do (*circa* 1600 BCE).

6. (Continuation) What is the effect of changing the seed value?

7. A coin is tossed n times. Let $p(n)$ be the probability of obtaining exactly three heads. It is written this way because it depends on the value of n . Calculate $p(3)$, $p(4)$, and $p(5)$, and then write a formula for $p(n)$. What is the domain of p ? What is $\lim_{n \rightarrow \infty} p(n)$?

8. The equation $f(x) = (x + 1)(x - 1)(x^2 + 4)$ defines a *quartic* function f . How many zeros does f have? How many x -intercepts does the graph of $y = f(x)$ have?

9. The product of the complex numbers $\text{cis}(35)$ and $\text{cis}(21)$ can itself be written in the form $\text{cis}\theta$. What is θ ? What is the product of $4 \text{cis}(35)$ and $3 \text{cis}(21)$?

10. The *slope of the curve* $y = 2^x$ at its y -intercept is slightly less than 0.7, while the slope of the curve $y = 3^x$ at its y -intercept is nearly 1.1. This suggests that there is a number b for which the slope of the curve $y = b^x$ is exactly 1 at its y -intercept. The figure shows the line $y = 1 + x$, along with the graph of $y = k^x$, where k is slightly smaller than the special number b . The curve crosses the line at $(0, 1)$ and (as the magnified view shows) at another point Q nearby in the first quadrant. Given the x -coordinate of Q , it is possible to calculate k by just solving the equation $k^x = 1 + x$ for k . Do so when $x = 0.1$, when $x = 0.01$, and when $x = \frac{1}{n}$. The last

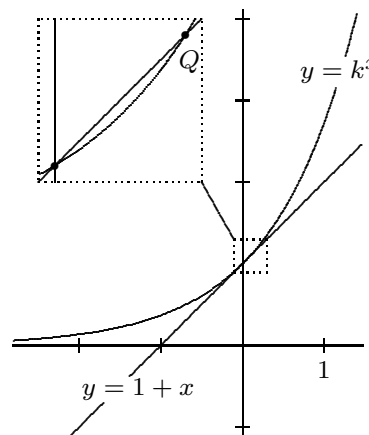

answer expresses k in terms of n ; evaluate the limit of this expression as n approaches infinity, and deduce the value of b . What happens to Q as n approaches infinity?

Mathematics 4C

1. When logarithms are calculated using e as the base, they are called *natural*, and the function is named \ln . Graph the equation $y = e^x$ and (using the LN key) the equation $y = \ln x$ on the same screen. What is the slope of the logarithm curve at its x -intercept? There is a simple matching of the points on one curve and the points on the other curve. What can be said about the slopes of the curves at a pair of corresponding points? By the way, the *slope of a curve at a point* means the slope of the tangent line at that point.

2. Write $(1 + i)^8$ in standard $a + bi$ form.

3. Given a positive number b other than 1, the polar equation $r = b^{\theta/360}$ represents a *logarithmic spiral*. Such a graph crosses the positive x -axis infinitely many times. What can be said about the sequence of crossings? What about the intercepts on the negative x -axis? What if b is less than 1? Examine these questions using the examples $b = 3$, $b = 1.25$, $b = 0.8$, and $b = \frac{1}{3}$.

4. A standard six-sided die is to be rolled 3000 times. Predict the average result of all these rolls. The correct answer to this question is called the *expected value* of rolling a die. What is the expected *sum* of two dice? of ten dice? of n dice?

5. How many ways are there of arranging the six numbers on a die? The diagram shows the standard way of arranging one, two, and three, and it is customary to put six opposite one, five opposite two, and four opposite three. This is just *one* way of doing it, however.

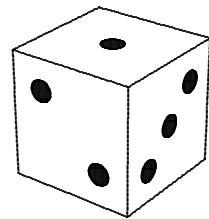

6. The sine graph has many symmetries, each of which can be described by means of an identity. For example, the sine graph has point symmetry at the origin, thus the sine function fits the identity $f(x) + f(-x) = 0$. Find at least three other specific symmetries of the sine graph and describe them using identities.

7. The expression $\lim_{n \rightarrow \infty} \left(1 + \frac{2}{n}\right)^n$ may remind you of the definition $e = \lim_{k \rightarrow \infty} \left(1 + \frac{1}{k}\right)^k$. It is in fact possible to find a simple relationship between the values of the two limits. You could start by replacing n by $2k$. After you have expressed the value of the first limit in terms of e , try to generalize, by expressing the value of $\lim_{n \rightarrow \infty} \left(1 + \frac{r}{n}\right)^n$ in terms of e , for any positive value of r .

8. A coin is tossed n times. Let $q(n)$ be the probability of obtaining at least three heads among these n tosses. Calculate $q(4)$, then write a formula for $q(n)$. What is the domain of q ? What is the limiting value of $q(n)$ as n becomes very large?

9. When $x = -1/2$, the infinite series $1 + x + x^2 + x^3 + \dots$ converges to $2/3$. When $x = 3/5$, the infinite series $1 + x + x^2 + x^3 + \dots$ converges to $5/2$. Besides $2/3$ and $5/2$, what are the other possible values to which $1 + x + x^2 + x^3 + \dots$ can converge?

Mathematics 4C

1. Working in degree mode, graph the polar equation $r = 4 \cos \theta$ for $0 \leq \theta \leq 180$. Identify the configuration you see. Find Cartesian coordinates for the point that corresponds to $\theta = 180$. You will notice that this example requires that an adjustment be made in the definition of the polar coordinate system.
2. Unlike Cartesian coordinates, polar coordinates are not uniquely determined. Choose a point in the plane and — working in degree mode — find four different ways of describing it using polar coordinates, restricting yourself to angles from the interval $-360 \leq \theta \leq 360$.
3. Write $(2+i)^2$, $(2+i)^3$, and $(2+i)^4$ in $a+bi$ form. Graph these three complex numbers along with $2+i$. Now write all four numbers in polar form. What patterns do you notice?
4. A truly remarkable property of complex multiplication is the angle-addition identity $\text{cis}(\alpha)\text{cis}(\beta) = \text{cis}(\alpha + \beta)$. Use it to derive the *theorem of De Moivre*, which says that $(r \text{cis } \theta)^n = r^n \text{cis}(n\theta)$ for any numbers r and θ , and any integer n . Calculate $(\sqrt{3} + i)^{18}$.
5. On the graph of $y = f(x)$, it is given that $(-2, 5)$ is the highest point, $(2, -7)$ is the lowest point, and $x = -4$, $x = 1$, and $x = 3$ are the x -intercepts. For each of the following, find the highest and lowest points on the graph, and all the x -intercepts.
 - (a) $y = 3f(2x)$
 - (b) $y = f(x - 5) + 8$

6. After being thrown from the top of a tall building, a projectile follows the path $(x, y) = (60t, 784 - 16t^2)$, where x and y are in feet and t is in seconds. The Sun is directly overhead, so that the projectile casts a moving shadow on the ground beneath it, as shown in the figure. When $t = 1$,

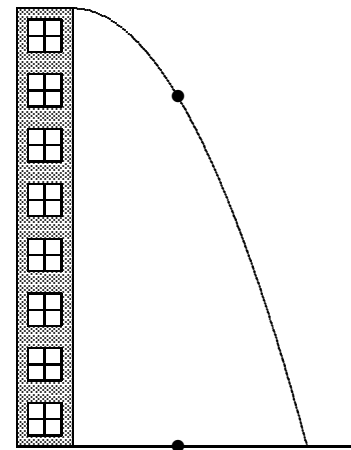

- (a) how fast is the shadow moving?
 - (b) how fast is the projectile losing altitude?
 - (c) how fast is the projectile moving?
7. (Continuation) What is the altitude of the projectile when $t = 2$? What is the altitude of the projectile a little later, when $t = 2 + k$? How much altitude is lost during this k -second interval? At what rate is the projectile losing altitude during this interval?
 8. (Continuation) Evaluate $\lim_{k \rightarrow 0} \frac{y(2+k) - y(2)}{k}$, recalling that $y(t) = 784 - 16t^2$ is the altitude of the projectile at time t . What is the meaning of this limiting value in the story?
 9. (Continuation) At what angle does the projectile strike the ground?
 10. Asked to evaluate $\lim_{n \rightarrow \infty} \left(1 + \frac{0.5}{n}\right)^n$, Herbie quickly answered, “It’s simple; 1 to any power is just 1.” Avery disagreed, “It’s an indeterminate form; the answer is actually greater than 1.” Who is correct, and why?

Mathematics 4C

1. Three numbers, x , y , and z , are to be randomly chosen between 0 and 1.
 - (a) What is the probability that $x + y + z$ will be less than 1?
 - (b) What is the probability that both $x + y < 1$ and $1 < x + y + z$?

2. Asked on a test to simplify i^{83} , Lee wrote the following solution:

$$i^{83} = (\sqrt{-1})^{83} = \left((-1)^{1/2}\right)^{83} = \left((-1)^{83}\right)^{1/2} = (-1)^{1/2} = \sqrt{-1} = i$$

How would you grade this solution?

3. Graph the functions $f(x) = \frac{x}{2}$ and $g(x) = \frac{5}{2x}$, using the window $-15 \leq x \leq 15$ and $-10 \leq y \leq 10$. In the same window, graph $R(x) = \frac{1}{2}\left(x + \frac{5}{x}\right)$, and explain any asymptotic behavior you see.
4. (Continuation) Draw the web diagram that corresponds to the root-finding sequence defined recursively by $x_0 = 1$ and $x_n = R(x_{n-1})$.
5. Apply the dilation with magnification factor 3 and center $(0, 0)$ to the points of the spiral $r = 3^{\theta/360}$. Give a detailed description of the resulting configuration of points.
6. In degree mode, the numbers $\text{cis } 90$, $\text{cis } 180$, $\text{cis } 270$, and $\text{cis } 360$ have much simpler names. What are they?
7. Consider the ellipse of eccentricity $\frac{1}{3}$ that has the origin as one focus and the vertical line $x = -24$ as the corresponding directrix. Find a *polar equation* for this *conic section*.

8. Verify that $|x^2 - 4| < 0.0001$ is true for all numbers x that are sufficiently close to 2. In other words, show that the inequality is satisfied if the distance from 2 to x is small enough. How small is “small enough”?

9. (Continuation) *What “limit” means:* Let p be any small positive number. Show that there is another small positive number d , which depends on p , that has the following property: whenever $|x - 2| < d$ it is true, it is also true that $|x^2 - 4| < p$. This means —intuitively— that x^2 can be brought arbitrarily close to 4 by making x suitably close to 2. It is customary to summarize this situation by writing $\lim_{x \rightarrow 2} x^2 = 4$. In describing how to find the number d , it will be convenient to assume at the outset (there being no loss of generality in doing so) that p -values greater than 4 are not under consideration.

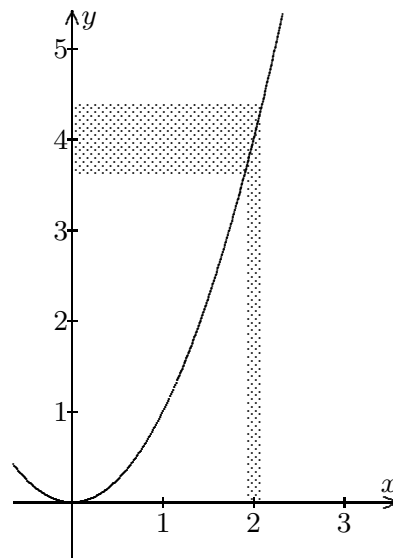

Mathematics 4C

1. Multiply $a + bi$ times $c + di$. Consider the special case when $a = \cos \theta$, $b = \sin \theta$, $c = \cos \phi$, and $d = \sin \phi$. You should see a couple of familiar formulas. Use them to prove the angle-addition property of complex multiplication.
2. Fresh from the pot, a cup of tea is initially 212 degrees. After six minutes of sitting in a 68-degree room, its temperature has dropped to 190 degrees. How many minutes will it take for the tea to be drinkable, which is when its temperature has reached 150 degrees?
3. Graph $f(x) = \frac{2x - 3}{x + 1}$, identifying all asymptotic behavior. Find the domain and the range of f . Notice that the fraction $\frac{2x - 3}{x + 1}$ is an example of an *improper fraction*, and that the *long-division* process can be used to put this fraction into the *mixed form* $2 - \frac{5}{x + 1}$. How does putting the fraction into this form help explain the appearance of the graph $y = f(x)$? What is the significance of the number $\lim_{x \rightarrow \infty} \frac{2x - 3}{x + 1}$ for this graph? By the way, it can be shown that this graph is a hyperbola. Find equations for its axes of symmetry.
4. A zero of a function is sometimes called a *root* of that function.
 - (a) Find the roots of $f(x) = x^4 + 3x^2 - 4$.
 - (b) The function f defined by $f(x) = x^2 - 2x + 1$ has a *double root*. Explain.
5. Put your calculator in radian mode for the following question. The sequence recursively defined by $x_n = \cos(x_{n-1})$ *converges* to a limiting value, no matter what seed value x_0 is chosen. With the help of a web diagram, explain why this happens.
6. Given a complex number $a + bi$, its *conjugate* is the number $a - bi$. What geometric transformation is being applied? What happens when a complex number and its conjugate are multiplied? What happens when a complex number and its conjugate are added?
7. (Continuation) Show that the expression $\frac{1}{1 + i}$ can be written in $a + bi$ form. In other words, show that the *reciprocal of a complex number* is also a complex number.
8. You may have noticed that the identity $\text{cis}(\alpha)\text{cis}(\beta) = \text{cis}(\alpha + \beta)$ is in exactly the same form as another familiar rule you have learned about. What rule? By the way, there is a rule for *cis* that covers *division* in the same way that the above rule covers multiplication. Discover the rule, test it on some examples, then use it to find the polar form of $\frac{1}{\text{cis } \theta}$.

Mathematics 4C

1. What is the probability that the top two cards of a standard, shuffled 52-card deck have the same color (both are red or both are black)?
2. A bowl contains a mixture of r red and b brown candies. Find values of r and b so that there is exactly a 50 percent chance that the colors of two randomly chosen candies will not match. There are many possibilities, including $r = 15$ and $b = 10$. Verify that these values work, then find other values for r and b (*besides* $r = 10$ and $b = 15$) that are consistent with this information. You could try small values for r and b .
3. Consider the cubic graph $y = 3x^2 - x^3$.
 - (a) Write $3x^2 - x^3$ in factored form.
 - (b) Use this form to explain why the graph lies below the x -axis only when $x > 3$, and why the origin is therefore an *extreme point* on the graph.
 - (c) Use preceding information to sketch the cubic graph.
4. (Continuation) Let $f(x) = 3x^2 - x^3$, and $g(x) = f(x + 1) - 2$.
 - (a) Use algebra to arrive at an unparenthesized expression for $g(x)$.
 - (b) What does the expression tell you about the graph of $y = f(x)$?
 - (c) Use the preceding to find another extreme point on the graph of $y = f(x)$.
5. Express all the solutions to the following equations in $a + bi$ form:
 - (a) $z^2 + 2z + 4 = 0$
 - (b) $z^3 - 8 = 0$ [*Hint: $z^3 - 8 = (z - 2)(z^2 + 2z + 4)$*]
 - (c) $2z + iz = 3 - i$
6. Sasha and Avery each have a fifteen-minute project to do, which requires the use of a special machine in the art studio that is available only between 4 pm and 6 pm today. Each is unaware of the other's intentions, and will arrive at the studio at a random time between 4 pm and 5:45 pm, hoping to find the machine free. If it is not, the work will be postponed until tomorrow. Thus at least one of them will succeed today. What is the probability that Sasha and Avery *both* complete their projects today?
7. For what value of x does the infinite geometric series $1 + x + x^2 + x^3 + \dots$ converge to 3? For what value of x does $1 + x + x^2 + x^3 + \dots$ converge to 1996? For what values of x does it make sense to talk about the *sum* of the infinite geometric series $1 + x + x^2 + x^3 + \dots$?
8. (Continuation) The sum of the series depends on the value of x , and it is therefore a function of x . What is the domain of this function? What is the range? What are the significant features of the graph of this function?

Mathematics 4C

1. Tell how the slope of the curve $y = 3^x$ at its y -intercept compares with the slope of the curve $y = 2 \cdot 3^x$ at its y -intercept.

2. The plant *Herba inutilis* is shown at right. Its branches develop according to a fixed timetable: Starting when it has reached the age of two weeks, a mature branch generates a new branch every week, by forming a fork at its end. Five weeks after sprouting, there are five branches. Add the sixth level to the diagram. How many branches will there be after ten weeks?

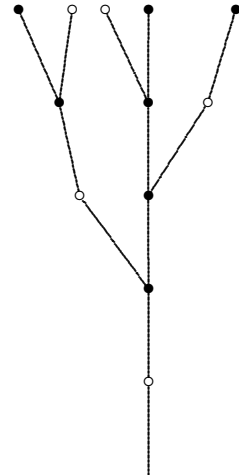

3. The *Fibonacci sequence* is generated by the two-term recursion $x_n = x_{n-1} + x_{n-2}$, proceeding from the initial values $x_1 = 1$ and $x_2 = 1$. Verify that $x_5 = 5$, then calculate x_{10} .

4. Working in radian mode, draw the graph of $y = \sin x$ for $-2\pi \leq x \leq 2\pi$. Find the slope of this curve at the origin. Would the slope have been different if you had worked in degree mode?

5. (Continuation) Working in radian mode, evaluate $\lim_{x \rightarrow 0} \frac{\sin x}{x}$. Interpret your answer.

6. The *divide-and-average* function $R(x) = \frac{1}{2}\left(x + \frac{5}{x}\right)$ finds the square roots of 5 when it is applied recursively to nonzero seed values. By modifying this design, obtain a function that finds the *cube root* of 5 rapidly when it is applied recursively to a positive seed value.

7. Find an example of an *odd* function f that has the additional property that the function g defined by $g(x) = f(x - 18)$ is *even*.

8. How do the slopes of the curves $y = m \sin x$ and $y = \sin x$ compare at the origin? Working in radian mode, also compare the slope of the curve $y = m \sin x$ at $(\pi, 0)$ with the slope of $y = \sin x$ at $(\pi, 0)$. Is it possible to compare slopes for other points on these two curves?

9. Show that $x^2 + y^2$ can be factored, if one can use non-real numbers in the answer.

10. For what value of x does the infinite geometric series $5 + 15x + 45x^2 + \dots$ converge to 3? For what value of x does $5 + 15x + 45x^2 + \dots$ converge to 2011? For what values of x does it make sense to talk about the *sum* of the infinite geometric series $5 + 15x + 45x^2 + \dots$?

Mathematics 4C

1. Sketch the graph of $f(x) = \frac{x^2}{x-1}$. Identify all asymptotic behavior. What are the domain and the range of f ? Notice that the fraction $\frac{x^2}{x-1}$ is another example of an improper fraction, and that the long-division process can be used to put this fraction into the mixed form $x + 1 + \frac{1}{x-1}$. How does putting the fraction into this form help explain the appearance of the graph $y = f(x)$?
2. Calculate and graph the complex numbers $z_n = (1+i)^n$ for $n = -1, 0, 1, \dots, 8$. Show that these points lie on a spiral of the form $r = b^{\theta/360}$. In other words, find a value for the base b . (Try to do this exercise without using SpiReg.)
3. Consider sequences defined recursively by $x_0 = 1$ and $x_n = 1 + mx_{n-1}$. For what values of m will the resulting sequence converge? Illustrate your reasoning with web diagrams.
4. Ryan spent a dollar on a Tri-State Megabucks ticket, enticed by a big jackpot. Ryan chose six different numbers from 1 to 40, inclusive, hoping that they would be chosen later during the TV drawing. Sad to say, *none* of Ryan's choices were drawn. What was the probability of this happening? The order in which numbers are drawn is of no significance.
5. Which is true? (a) $\frac{8!}{4!} = 4!$ (b) $(a+b)! = a! + b!$ (c) $0! = 1$ (d) $m!n! = (mn)!$
6. Graph the hyperbola $r = \frac{6}{1 - 2 \sin \theta}$. The origin is a focus. Notice the two rays on which no r -value can be plotted. These rays tell you something about the asymptotes of the hyperbola. Explain. Notice that the asymptotes of this example do not go through the origin! Write a Cartesian equation for the hyperbola, and find its eccentricity.
7. Evaluate the sums (a) $\sum_{n=1}^{5280} (-1)^n n$ (b) $\sum_{n=0}^{5280} i^n$ (c) $\sum_{n=0}^{5280} \left(\frac{i}{2}\right)^n$
8. Rewrite $\sum_{m=0}^{5280} \binom{5280}{m} x^{5280-m} y^m$ without using sigma notation. By the way, $\binom{n}{r}$ is just another name for the binomial coefficient ${}_n C_r$.
9. The spiral $r = 3^{\theta/360}$ makes an 80.1-degree angle with the positive x -axis.
 - (a) Apply a counterclockwise quarter-turn at $(0, 0)$ to the points of this spiral. What angle does the image spiral make with the positive y -axis?
 - (b) Radially dilate the image spiral by a factor of $3^{1/4}$. Show that this re-creates the original spiral $r = 3^{\theta/360}$.
 - (c) What angle does the original spiral $r = 3^{\theta/360}$ make with the positive y -axis?
10. For what values of x does it make sense to talk about the sum of the infinite geometric series $1 + 2x + 4x^2 + 8x^3 + \dots$? What is the range of possible sums? Express this series using sigma notation.

Mathematics 4C

1. You have seen an example of a quartic polynomial whose graph has two x -intercepts. On the other hand, the graph of $y = x^4 + 1$ has none. Can you find quartic examples that have exactly *one* x -intercept? *three* x -intercepts? *four* x -intercepts? *five* x -intercepts? If so, give examples. If not, why not?

2. The point $(1, 1)$ is on the graph of $y = x^3$. Find coordinates for another point *on the graph* and very close to $(1, 1)$. Find the slope of the line that goes through these points. Explain how this slope is related to the value of $\lim_{x \rightarrow 1} \frac{x^3 - 1}{x - 1}$. This limit is an example of an indeterminate form.

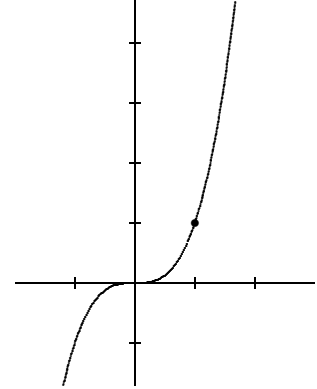

3. (Continuation) First show that $x^3 - 1$ is divisible by $x - 1$, then show that $x^3 - 8$ is divisible by $x - 2$. One way to proceed is to use the long-division process for polynomials. Show that your results could be useful in finding the slope of a certain curve.

4. Recall that the slope of the curve $y = e^x$ at its y -intercept is 1. Use this information to find the slopes of the curves $y = e^{2x}$ and $y = e^{mx}$ at their y -intercepts.

5. (Continuation) Justify the identity $2^x = e^{x \ln 2}$. Apply this equality to the problem of finding the slope of the curve $y = 2^x$ at its y -intercept.

6. As you know, there are $6! = 720$ ways to arrange the letters of *parked* to form six-letter words. How many ways are there to arrange the letters of *peeked* to form six-letter words?

7. The recursive method of defining sequences of numbers can also be used to define sequences of points (or vectors). For example, start with the seed point $(x_0, y_0) = (1, 0)$ and apply the definitions $x_n = 0.866025x_{n-1} - 0.5y_{n-1}$ and $y_n = 0.5x_{n-1} + 0.866025y_{n-1}$ twelve times. Are you surprised by your values for x_{12} and y_{12} ?

8. Invent a function f whose graph has the vertical lines $x = 1$ and $x = 9$ as lines of reflective symmetry. What other lines of reflective symmetry must your example have?

9. The quadratic equation $2z^2 + 2iz - 5 = 0$ has two solutions. Find them. By the way, the quadratic formula is valid for non-real quadratic equations.

10. Show that the quotient $\frac{7 + 24i}{2 + i}$ can be simplified to $a + bi$ form.

11. Recall that the slope of the curve $y = \sin x$ at the origin is 1, when graphed in radian mode. Use this information to find the slope of the curve $y = \sin 2x$ at the origin. Answer the same question for $y = \sin mx$, $y = 3 \sin x$, and $y = 2 \sin \left(\frac{1}{2}x\right)$.

12. Graph $f(x) = \frac{x^3 - 1}{x - 1}$. What are the domain and range of f ?

Mathematics 4C

1. Ryan spent a dollar on a Tri-State Megabucks ticket, enticed by a big jackpot. Ryan chose six different numbers from 1 to 40, inclusive, hoping that they would be the *same* numbers drawn later by lottery officials. This time the news was a little better — exactly *one* of Ryan's choices was drawn. What was the probability of this happening? The order in which the numbers are drawn is of no significance.

2. (Continuation) The following week, Ryan spent a dollar on a Tri-State Megabucks ticket. State and solve the next question in this continuing saga.

3. A circular disk, whose radius is 6 inches, is spinning at 10 rpm. Crawling at a steady rate, a bug makes the 6-inch journey from the center of the disk to the rim in one minute. Find an equation, in polar coordinates, for the *Archimedean spiral* traced by the bug.

4. Draw a square with vertices $(0, 0)$, $(1, 0)$, $(1, 1)$, and $(0, 1)$, then draw an adjacent $r \times r$ square with vertices $(1, 0)$ and $(1 + r, 0)$, as shown at right. In terms of r , find the x -intercept of the straight line that goes through the upper right corners of the two squares. Your answer should look familiar. Why?

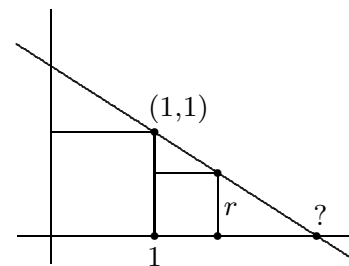

5. Draw the web diagram for the sequence defined recursively by $x_0 = 2.54$ and $x_n = \frac{x_{n-1} - 1}{x_{n-1}}$. Choose another seed value and repeat. Hmm...

6. Consider the sequence of complex numbers $z_n = \left(1 + \frac{1}{10}i\right)^n$. It is understood that n stands for a nonnegative integer. Notice that z_1 and z_2 are in the first quadrant. What is the smallest positive value of n for which z_n is in the second quadrant?

7. On the same system of coordinate axes, sketch both of the graphs $y = \cos x$ and $y = \frac{1}{\cos x}$. The reciprocal of the cosine is usually called *secant*. Explain why the secant graph has vertical asymptotes. What is the domain of secant? What is its range?

8. The figure at right shows the graph $y = f(x)$ of an unspecified function f . On the same system of coordinate axes, sketch a detailed graph of the reciprocal function $y = \frac{1}{f(x)}$.

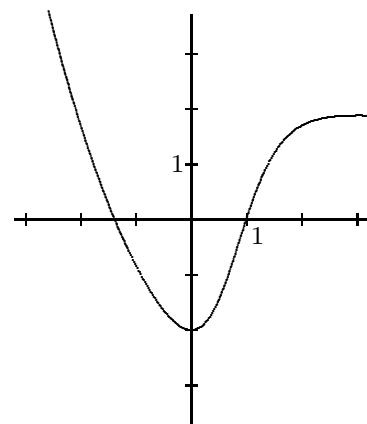

9. Show that $\frac{n!}{(n-r)!}$ is equivalent to ${}_n P_r$, by rewriting the expression without using factorial signs or the fraction bar.

10. When the binomial power $(3x - 2y)^2$ is multiplied out, the numerical coefficient of the xy term is -12 . When the binomial power $(3x - 2y)^{10}$ is multiplied out, what is the numerical coefficient of the x^3y^7 term?

11. Graph $f(x) = \frac{x^2 - 1}{x + 1}$. What are the domain and range of f ?

Mathematics 4C

1. Graph the polar equation $r = \frac{6k}{1 - k \cos \theta}$ for each of the three cases $k = 0.5$, $k = 1$, and $k = 2$. What do these three curves have in common? How do they differ?
2. Pat reaches into a bowl containing twenty distinguishable pieces of candy and grabs a handful of four. How many different handfuls of four are there? Suppose next that ten of the pieces are red and ten are brown. How many handfuls of four consist of two reds and two browns? What is the probability that a random four-piece handful will have two of each color?
3. (Continuation) Four pieces are selected from the bowl, one after another. What is the probability that the first two pieces are red and the last two pieces are brown? Why does this number not agree with your answer to the previous question?
4. (Continuation) What is the probability that a random handful of four will contain only one color?
5. Choose a positive integer x_0 . Apply the recursion $x_n = \begin{cases} 3x_{n-1} + 1 & \text{if } x_{n-1} \text{ is odd} \\ \frac{1}{2}x_{n-1} & \text{if } x_{n-1} \text{ is even} \end{cases}$ to it repeatedly. Does your sequence exhibit any interesting behavior? Does the choice of seed value x_0 affect the answer to this question? Did you consider the seed value $x_0 = 27$?
6. Graph the function h that is defined by $h(x) = \frac{2^x}{1 + 2^x}$ for all real values of x . Identify the asymptotic behavior. Describe the symmetry of the graph of h .
7. Courtney is running laps on a 165-yard track. Describe Courtney's position relative to the starting line after running 1760 yards.
8. (Continuation) Courtney's distance from the starting line is a function of the number of yards that Courtney has run. Draw a graph of this function. You will need to decide what the phrase "distance from the starting line" means. Be ready to explain your interpretation.
9. Given only that the period of the function f is 165, find the least positive number p for which $f(1760) = f(p)$.

10. The figure at right shows the graph $y = f(x)$ of an unspecified function f . On the same system of coordinate axes, sketch a detailed graph of the reciprocal function $y = \frac{1}{f(x)}$.

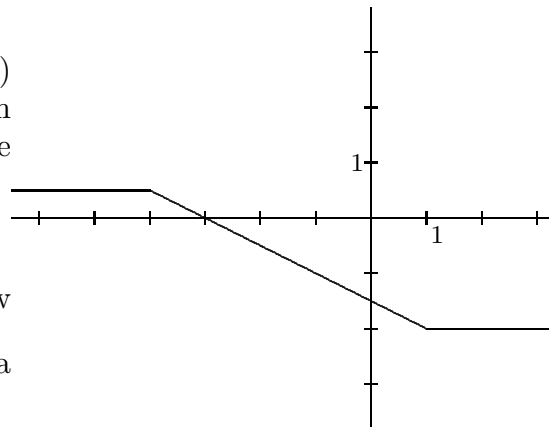

11. Find the sum of the series $\sum_{n=0}^{\infty} \left(\frac{1+i}{2}\right)^n$. Now think of the series as a sum of vectors, and draw a spiral to illustrate your answer.

Mathematics 4C

1. The point $P = (2, 1)$ is on the hyperbola $xy = 2$. Find the slope of the line tangent to the curve at P . Start by letting Q be a point on the curve whose x -coordinate is $2+h$, where h stands for a small number. Use algebra to calculate what happens to the slope of line PQ when h approaches zero.

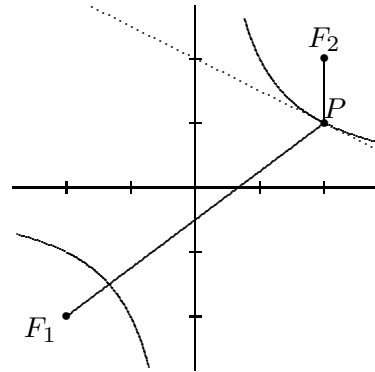

2. (Continuation) The tangent line bisects the angle F_1PF_2 formed by the focal radii drawn from P to $F_1 = (-2, -2)$ and $F_2 = (2, 2)$. Find a way to show this. There are several methods from which to choose.

3. For what values of x is it true that $x = \cos(\cos^{-1} x)$? Does it matter whether your calculator is in degree mode or radian mode for this question?

4. (Continuation) Graph the composite function C defined by $C(x) = \sin(\cos^{-1} x)$. It should look familiar. Can you find another way to describe the same graph?

5. For what values of t is it true that $t = \cos^{-1}(\cos t)$? Does it matter whether your calculator is in degree mode or radian mode for this question?

6. The slope of the curve $y = 2^x$ at its y -intercept is $\ln 2$, which is approximately 0.693. Use this information (but no calculator) to find the slope of the curve $y = 3 \cdot 2^x$ at its y -intercept. Answer the same question for $y = 2^3 \cdot 2^x$, then use your result to find the slope of the curve $y = 2^x$ at the point $(3, 8)$.

7. (Continuation) What is the slope of the curve $y = 2^x$ at the point on the curve whose y -coordinate is 5?

8. Find the slope of (a) the curve $y = e^3 e^x$ at the point $(0, e^3)$; (b) the curve $y = e^x$ at the point $(3, e^3)$; (c) the curve $y = e^x$ at the point (a, e^a) .

9. Find both square roots of i and express them in polar form and in Cartesian form.

10. The Fibonacci sequence is defined recursively by $f_1 = 1$, $f_2 = 1$, and $f_n = f_{n-1} + f_{n-2}$. Show that this recursive description can also be presented in matrix form

$$\begin{bmatrix} f_1 \\ f_2 \end{bmatrix} = \begin{bmatrix} 1 \\ 1 \end{bmatrix} \quad \text{and} \quad \begin{bmatrix} f_{n-1} \\ f_n \end{bmatrix} = \begin{bmatrix} 0 & 1 \\ 1 & 1 \end{bmatrix} \begin{bmatrix} f_{n-2} \\ f_{n-1} \end{bmatrix} \quad \text{for } 3 \leq n$$

Use matrix multiplication to calculate $\begin{bmatrix} f_2 \\ f_3 \end{bmatrix}$, $\begin{bmatrix} f_3 \\ f_4 \end{bmatrix}$, and $\begin{bmatrix} f_{39} \\ f_{40} \end{bmatrix}$.

11. The irrational numbers $5 + \sqrt{3}$ and $5 - \sqrt{3}$ are called *conjugates*. Invent a quartic polynomial with integer coefficients that has four real roots, including these conjugates.

Mathematics 4C

1. If you were to calculate a few terms of a sequence defined by $z_n = \frac{1}{2} \left(z_{n-1} + \frac{3+4i}{z_{n-1}} \right)$, what would you expect to find? Try the seed values $z_0 = 1 + 3i$, $z_0 = 2 - 5i$, and $z_0 = 4i$. Do your results depend on the choice of seed value?
2. Zuza has a cube with each face painted a different color, and wants to number the faces from 1 to 6, so that each pair of nonadjacent faces sums to 7. In how many different ways can such a numbering be done?
3. A basket contains four red apples and an unspecified number of green apples. Four apples are randomly selected. What is the smallest number of green apples that makes the probability of finding at least one green apple among the four at least 99.9 percent?
4. (Continuation) What is the smallest number of green apples that makes the probability of choosing four green apples at least 99.9 percent?
5. Ryan has a new game — *Powerball*. Enticed by a big jackpot, Ryan chose five different numbers from 1 to 45, then an additional number — called the Powerball number — also from 1 to 45. The order of the first five numbers is not important, and the Powerball number can duplicate one of the first five choices. What is the probability that these will match the numbers (first five, then one) drawn later by the lottery officials?
6. A connected chain of ${}_{45}C_5 \cdot 45$ pennies has been laid out, each penny placed head side up. Given that the diameter of a penny is 0.75 inches, calculate the length of this chain. Suppose that the tail side of one of the pennies has been painted red, and that — for a dollar — you get to turn one of the pennies over. If you choose the marked penny, you win a \$300 million jackpot. Would you play this game?
7. A one-dimensional, five-step random walk starts at the origin, and each step is either one unit to the right or one unit to the left. If this five-step walk is to be performed 32000 times, what is your prediction of the average of all the final positions? This is an expected-value question.
8. (Continuation) Before beginning a one-dimensional, five-step random walk, what would you predict the distance from the origin to the final position to be? If this five-step walk is to be performed 32000 times, what is your prediction of the average of all the distances from the origin to the final position?
9. Let f_n stand for the n^{th} term of the Fibonacci sequence. What is remarkable about the sequence of differences $d_n = f_n - f_{n-1}$? What about the sequence of ratios $r_n = f_n/f_{n-1}$?
10. Graph the function f defined by $f(x) = \frac{x^4 + 3x^2 - 4}{x^2 - 1}$. Find equations for all linear asymptotes. Describe all symmetries. What are the domain and range of f ?

Mathematics 4C

1. *One-sided limits.* Consider the *sign function*, which is defined for all nonzero values of x by $\operatorname{sgn}(x) = \frac{x}{|x|}$. Confirm that both $\lim_{x \rightarrow 0^-} \operatorname{sgn}(x)$ and $\lim_{x \rightarrow 0^+} \operatorname{sgn}(x)$ exist, and notice that they have different values. (The notation $x \rightarrow 0^+$ means that x approaches 0 from the right.) Because the two one-sided limits do not agree, $\operatorname{sgn}(x)$ does not approach a (two-sided) limit as $x \rightarrow 0$. Notice that $\operatorname{sgn}(0)$ remains undefined.

2. It is a fact that the square root of 2 is the same as the fourth root of 4 — in other words, $2^{1/2} = 4^{1/4}$. Thus the graph of $y = x^{1/x}$ goes through two points that have the same y -coordinate. As the diagram suggests, the maximum y -value for this curve occurs between $x = 2$ and $x = 4$. What is this x -value, to four places?

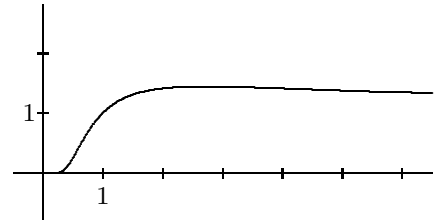

3. (Continuation) The diagram also suggests that the graph of $y = x^{1/x}$ has a horizontal asymptote. Investigate this possibility.

4. Verify that $z = 2(1 + i\sqrt{3})$ is one of the roots of $z^3 + 64 = 0$. Find the other two and then graph all three.

5. Identify the asymptotic behavior in the graph of $y = \frac{x^2 - 1}{x^2 + 1}$, and explain why it occurs. Use limit notation to describe what you see.

6. Evaluate: (a) $\lim_{x \rightarrow \infty} \tan^{-1} x$ (b) $\lim_{x \rightarrow -\infty} \tan^{-1} x$ (c) $\lim_{x \rightarrow 0} \frac{\sin mx}{x}$ (d) $\lim_{x \rightarrow 1} \frac{x^2 - 1}{x - 1}$
Work in radian mode for (a)—(c). Notice that (c) and (d) do not deal with asymptotes.

7. The graph of the equation $y = \frac{x^3 - x^2 - 4x - 1}{x^2 + 1}$ is shown at right. Identify the linear asymptote. It helps to use polynomial division to convert this *improper fraction* to a mixed expression. Does this graph have any symmetry? Discuss.

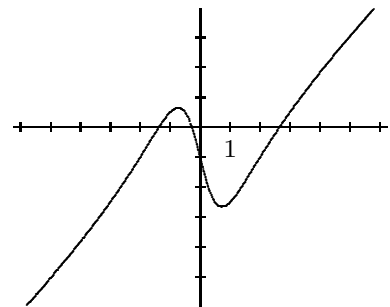

8. The quadratic function f is defined by $f(x) = x^2 - 3x$. Use algebra to evaluate $\lim_{h \rightarrow 0} \frac{f(2+h) - f(2)}{h}$. What is the meaning of the answer?

9. (Continuation) Calculate $\lim_{h \rightarrow 0} \frac{f(x+h) - f(x)}{h}$. What does this limit represent?

10. Calculate the slope of the curve $y = \ln x$ at the five points where $x = 1, 2, 4, 5,$ and 8 . Do you notice a pattern in your answers? Try other examples to confirm your hunch.

11. Graph $f(x) = \frac{x^2 - 2x}{x + 1}$. To identify the asymptotic behavior, it will help to convert the improper fraction to mixed form. What are the domain and the range of f ?

Mathematics 4C

1. The figure at right shows 68 terms of the infinite sequence $v_k = \left(1 + \frac{i}{40}\right)^k$. The points follow a spiral path that unwinds slowly from the unit circle (shown in part) as k increases. Notice that $v_0 = 1$ is *on* the unit circle and that v_{40} appears to be just barely *outside*. Confirm this by calculating the *magnitude* of v_{40} . Also calculate the *polar angle* of v_{40} (thinking of v_{40} as a vector that emanates from the origin). By the way, the radian system of measuring angles works very well in this problem and its continuations.

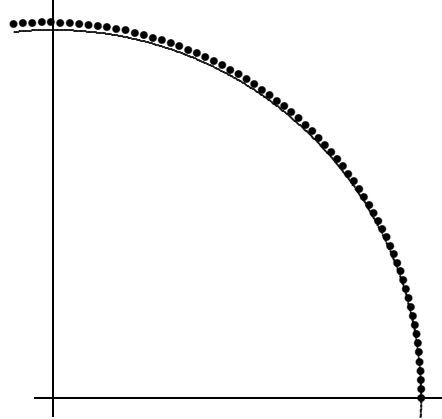

2. (Continuation) Let $w_k = \left(1 + \frac{i}{100}\right)^k$. This sequence also follows a spiral path that unwinds from the unit circle as k increases. If a figure were drawn for this example, how would it differ from the above figure? Calculate the magnitude and polar angle of w_{100} .

3. (Continuation) Choose a large positive integer n , and calculate the magnitude and the polar angle of $z_n = \left(1 + \frac{i}{n}\right)^n$. When you compare answers with your neighbor (whose large integer n probably differs from yours), what is going to occur?

4. (Continuation) You saw earlier this term that $\lim_{n \rightarrow \infty} \left(1 + \frac{r}{n}\right)^n = e^r$ is true for all positive real numbers r , and you have now just seen that $\lim_{n \rightarrow \infty} \left(1 + \frac{i}{n}\right)^n = \text{cis } 1$, in radian mode. This strongly suggests that e^i be *defined* as $\text{cis } 1$. Now consider $\lim_{n \rightarrow \infty} \left(1 + \frac{i\theta}{n}\right)^n$ for values of θ other than 1, which can all be treated in the same manner. Define each of the following as a complex number: (a) e^{2i} (b) e^{-i} (c) $e^{i\pi}$ (d) $e^{i\theta}$

5. Sum the series

$$\frac{1}{32} + \frac{5}{32} + \frac{10}{32} + \frac{10}{32} + \frac{5}{32} + \frac{1}{32} \quad \text{and} \quad 0 \cdot \frac{1}{32} + 1 \cdot \frac{5}{32} + 2 \cdot \frac{10}{32} + 3 \cdot \frac{10}{32} + 4 \cdot \frac{5}{32} + 5 \cdot \frac{1}{32}$$

Find a context in which these sums have meaningful (or predictable) values.

6. Working in degree mode, simplify the sum $\text{cis } 72 + \text{cis } 144 + \text{cis } 216 + \text{cis } 288 + \text{cis } 360$.

7. The probability of obtaining exactly ten heads when twenty coins are tossed is about 17.6 percent. What is the probability that the number of heads will be somewhere between nine and eleven (inclusive) when twenty coins are tossed?

8. If $a + bi = (3 + 4i)^2$, where a and b are real numbers, then what can be said about the values of a and b ?

9. Choose positive values for x_0 and x_1 that no one else will think of, then calculate seven more terms of the sequence defined recursively by $x_n = \frac{1 + x_{n-1}}{x_{n-2}}$. What do you notice?

Mathematics 4C

1. A function f is said to be *continuous at a* , provided that $f(a) = \lim_{x \rightarrow a} f(x)$. If f is continuous at every point in its domain, it is called a *continuous function*. Most functions in this book are continuous, but here is an odd example: Let $F(x)$ be the fractional part of x . Thus $F(98.6) = 0.6$, $F(\pi) \approx 0.1416$, $F(2) = 0$, and $F(-2.54) = -0.54$. Find the x -values at which F is *discontinuous*. Illustrate your answer by drawing the graph of F .

2. Consider the honeycomb pattern shown at right, which consists of two rows of numbered hexagons. A honeybee crawls from hexagon number 1 to hexagon number 13, always moving from one hexagon to an adjacent hexagon whose number is greater. How many different paths are there? *Hint*: Let $p(n)$ denote the number of paths from hexagon 1 to hexagon n , and assume that $p(1) = 1$. It is easy to see the values of $p(2)$, $p(3)$, and $p(4)$. You should also see a pattern emerging.

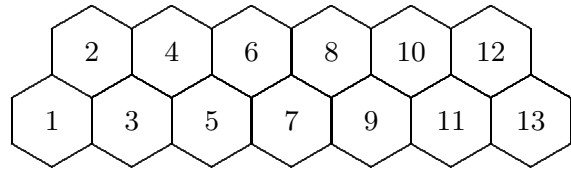

3. Find both square roots of $15 + 8i$, using any method you like.

4. Graph $y = \frac{b^x - 5}{b^x + 3}$, assuming that the base b is greater than 1. Identify both asymptotes. Does this graph have symmetry?

5. A standard six-sided die is rolled until two aces have appeared. What is the probability that this takes exactly ten rolls? On which roll is the second ace most likely to appear?

6. Working in degree mode, evaluate

(a) $\text{cis } 11 + \text{cis } 83 + \text{cis } 155 + \text{cis } 227 + \text{cis } 299$ and

(b) $\cos 11 + \cos 83 + \cos 155 + \cos 227 + \cos 299$.

Find a way to answer these questions without using your calculator.

7. The graph of $y = f(2x - 5)$ is obtained by applying first a horizontal translation and then a horizontal compression to the graph of $y = f(x)$. Explain. Is it possible to achieve the same result by applying first a horizontal compression and then a horizontal translation to the graph of $y = f(x)$?

8. Evaluate $\lim_{h \rightarrow 0} \frac{\sqrt{3+h} - \sqrt{3}}{h}$, and explain how the result can be interpreted in terms of a suitable graph. By the way, it is possible to obtain this limit without a calculator approximation.

9. Recall that e is defined to be the value of $\lim_{n \rightarrow \infty} \left(1 + \frac{1}{n}\right)^n$. Use this definition and appropriate substitutions to evaluate the following:

(a) $\lim_{h \rightarrow 0} (1+h)^{1/h}$ (b) $\lim_{h \rightarrow 0} (1+5h)^{1/(5h)}$ (c) $\lim_{n \rightarrow \infty} \left(1 + \frac{1}{3n}\right)^n$ (d) $\lim_{n \rightarrow \infty} \left(1 + \frac{40}{n}\right)^{n/40}$

10. If $\lim_{x \rightarrow a} f(x) = L$ and $\lim_{x \rightarrow a} g(x) = M$, then $\lim_{x \rightarrow a} f(x)g(x) = LM$ can be proved. Use this fact to explain why the product of two continuous functions is itself continuous.

Mathematics 4C

1. The point $P = (0.5, 0.25)$ lies on the graph of $y = x^2$. Use the zoom feature of your calculator to look at very small portions of the graph as it passes through P . When the magnification is high enough, the graph looks like a straight line. Find a value for the slope of this apparent line. It is not surprising that this number is called *the slope of $y = x^2$ at $x = 0.5$* . Now calculate the slope of the same curve at a different x -value. Notice that the slope is twice the x -value you chose.
2. (Continuation) The preceding item stated that $2x$ serves as a *slope formula* for any point on the curve $y = x^2$. Confirm this by using algebra to evaluate $\lim_{h \rightarrow 0} \frac{(x+h)^2 - x^2}{h}$. Make a diagram that shows clearly what the symbol h represents.
3. (Continuation) You can achieve the same result by evaluating $\lim_{u \rightarrow x} \frac{u^2 - x^2}{u - x}$. Explain. Make a diagram that shows clearly what the symbol u represents.
4. Enter $y_1 = 3^x$ and $y_2 = \frac{y_1(x + 0.001) - y_1(x)}{0.001}$ into the function list in your calculator. (On some calculators, you can enter $y_2 = \text{nDeriv}(y_1(x), x)$ instead.) Make a table of values of y_1 and y_2 , for several x -values between -1 and 2 . Do you notice a relationship between the two columns? If not, enter $y_3 = y_2(x)/y_1(x)$ into the function list and look at the new column in the resulting table of values. This investigation should suggest a simple method for finding the slope at *any* point on the curve $y = 3^x$. What is the method?
5. (Continuation) First apply your knowledge of exponents to rewrite the expression $\frac{3^{a+h} - 3^a}{h}$ so that 3^a appears as a factor. Then use your calculator to evaluate $\lim_{h \rightarrow 0} \frac{3^h - 1}{h}$. Explain the relevance of this limit to the pattern observed in the preceding item.
6. (Continuation) Rewrite the equation $x = \frac{3^h - 1}{h}$ so that 3 appears by itself on one side of the equation. Then find the limiting value of the other side of the equation as h approaches 0 . It is straightforward to show that $e^x = \lim_{h \rightarrow 0} (1 + xh)^{1/h}$. This should help you to explain your answer to the preceding.
7. (Continuation) Show that $\lim_{h \rightarrow 0} \frac{3^h - 1}{h}$ and $\lim_{n \rightarrow \infty} n(3^{1/n} - 1)$ have the same value.
8. Find an expression for the slope at any point on the curve $y = (0.96)^x$. Do the same for the curves $y = -300(0.96)^x$ and $y = 375 - 300(0.96)^x$.
9. On page 301 you will find a radian-mode graph of $y = \sin x$ for $-2\pi \leq x \leq 2\pi$. The scales on the axes are the same. Estimate the slope of the graph at a dozen points of your choosing. On the second (blank) system of axes, plot this data (slope versus x). Connect the dots. Do you recognize the pattern? Why is radian measure for angles essential here?
10. (Continuation) Repeat the process for the curve $y = \cos x$, using page 301.

Mathematics 4C

1. After being dropped from the top of a tall building, the height of an object is described by $y = 400 - 16t^2$, where y is measured in feet and t is measured in seconds. Find a formula for the *rate of descent* (in feet per second) for this object. Your answer will depend on t .
2. The formula $A = (\cos t, \sin t)$ represents an object moving counterclockwise at 1 unit per second on the unit circle (radian measure!). Make a diagram that includes the *velocity vector* at point A , and write out its components. Your answer will depend on t .
3. (Continuation) Let $P = (0, \sin t)$ be the projection of A on the y -axis. As time passes, notice that P moves with varying speed up and down this axis. When P passes $(0, 0.6)$, its speed is 0.8 units per second. Make calculations that support this statement.

4. (Continuation) Because $\sin t$ is the y -coordinate of the object at A and its projection P on the y -axis, the previous problems both suggest that $\cos t$ is the rate at which $\sin t$ changes as t changes. Additional evidence can be found by analyzing the diagram. A short time h after the object is at A , it reaches B , and its y -axis projection reaches Q . The projection thus moves the distance PQ during time h , so its average speed is PQ/h . To calculate this ratio, explain why
 - (a) $PQ = AB \sin(BAP)$,
 - (b) $\angle BAP = \angle BAO - \angle PAO = \frac{1}{2}(\pi - h) - t$, and
 - (c) $\sin(BAP) = \cos(t + \frac{1}{2}h)$.

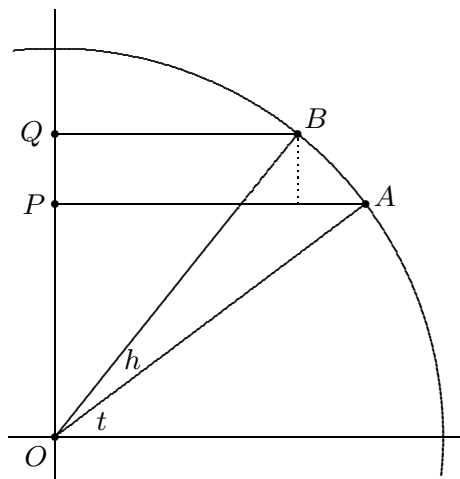

Now notice that chord AB is slightly shorter than arc AB , whose length is h , and thereby deduce that the average speed PQ/h is slightly less than $\cos(t + \frac{1}{2}h)$. Thus $\cos t = \lim_{h \rightarrow 0} \frac{\sin(t+h) - \sin(t)}{h}$ is the instantaneous speed.

5. The core temperature of a potato that has been baking in a 375-degree oven for t minutes is modeled by the equation $C = 375 - 300(0.96)^t$. Find a formula for the *rate of temperature rise* (in degrees per minute) for this potato. Your answer will depend on t .
6. Recall that the formula $A = (\cos t, \sin t)$ represents an object moving counterclockwise on the unit circle, with an angular speed of 1 radian per second. Let $P = (\cos t, 0)$ be the projection of A on the x -axis. As time passes, P moves with varying speed back and forth along the x -axis. Show that the *speed* of P when it passes $(0.28, 0)$ is 0.96 units per second. Show that the *velocity* of P could be either 0.96 or -0.96 . Explain this distinction. Create a diagram as above, and use it to evaluate $\lim_{h \rightarrow 0} \frac{\cos(t+h) - \cos(t)}{h}$.
7. (Continuation) Explain why it was essential that angles be measured in radians.
8. (Continuation) The diagram above shows a first-quadrant angle t . If t had been in one of the other three quadrants, would the answers to the rate questions for \sin and \cos have been the same? Make a new diagram to illustrate your answer.

Mathematics 4C

1. *The derivative.* You have recently answered several rate questions that illustrate a fundamental mathematical process. For example, you have seen that:

- if the position of a shadow on the y -axis is $\sin t$ at time t , then the velocity of the shadow is $\cos t$ at time t ;
- given any point on the graph $y = x^2$, the slope of the curve at that point is exactly twice the x -coordinate of the point;
- if the height of a falling object is $400 - 16t^2$ at time t , then the velocity of the object is $-32t$ at time t ;
- given any point on the graph $y = 3^x$, the slope of the curve at the point is exactly $\ln 3$ times the y -coordinate of the point;
- if an object is heated so that its temperature is $375 - 300(0.96)^t$ degrees at time t , then its temperature is increasing at a rate of $-300(0.96)^t \ln 0.96$ degrees per minute at time t .

In each of the five examples, a function is given:

$$y(t) = \sin t ; f(x) = x^2 ; h(t) = 400 - 16t^2 ; F(x) = 3^x ; C(t) = 375 - 300(0.96)^t$$

From these functions, new functions are derived by means of a limiting process:

$$v(t) = \cos t ; m(x) = 2x ; V(t) = -32t ; M(x) = 3^x \ln 3 ; R(t) = -300(0.96)^t \ln 0.96$$

A function derived in this way from a given function f is called the *derived function of f* , or simply the *derivative of f* , and it is often denoted f' to emphasize its relationship to f . The five functions derived above could therefore be named y' , f' , h' , F' , and C' , instead of v , m , V , M , and R , respectively. Each of them provides *rate information* about the given function. By the way, the use of primes to indicate derivatives is due to *Lagrange*.

(a) What is the derivative of the function E defined by $E(x) = b^x$? As usual, you should assume that b is a positive constant.

(b) Use algebra to find the derivative of the power function defined by $p(x) = x^3$.

2. Enter $y_1 = \sin x$ and $y_2 = \frac{y_1(x + 0.001) - y_1(x)}{0.001}$ into the function list in your calculator. Look at the graphs of these two functions on the interval $-\pi \leq x \leq \pi$. Does y_2 look the way you expected?

3. You have found the derivatives of at least two power functions. To be specific, you have shown that (a) the derivative of $f(x) = x^2$ is $f'(x) = 2x$, and that the derivative of $p(x) = x^3$ is $p'(x) = 3x^2$. This suggests that there is a general formula for the derivative of any function defined by $g(x) = x^n$, at least when n is a positive integer. First conjecture what you think this formula is. To obtain the correct formula, multiply out the binomial $(x + h)^n$, which should enable you to eliminate the fractions in $\lim_{h \rightarrow 0} \frac{(x + h)^n - x^n}{h}$.

4. A *linear function* has the form $L(x) = mx + b$, where m and b are constants (that means that the values of m and b do not depend on the value of x). You should not have to do too much work to write down a formula for the derivative $L'(x)$.

Mathematics 4C

1. A long elastic string of length a cm hangs freely from the ceiling, as shown. A weight attached to the free end stretches the string to length b cm. For each point x on the unstretched string, let $f(x)$ be its position on the stretched string, both distances being measured from the ceiling. Sketch a graph of the function f , assuming that the string stretches uniformly. Then sketch f , assuming that the string does *not* stretch uniformly. In each case, discuss the meaning of f' .

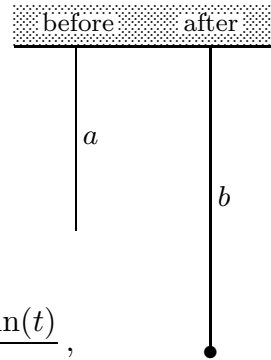

2. The expression $\frac{\sin(t+h) - \sin(t)}{h}$ can be written $\frac{\sin(t+\Delta t) - \sin(t)}{\Delta t}$, in which h is replaced by Δt . The symbol Δ (*Greek* “delta”) is chosen to represent the word *difference*. It is customary to call Δt the *change in t*. The corresponding *change in sin t* is $\sin(t+\Delta t) - \sin(t)$, which can be abbreviated $\Delta \sin t$. Notice that $\Delta \sin t$ depends on t as well as Δt . Working in radian mode, calculate $\Delta \sin t$ and $\frac{\Delta \sin t}{\Delta t}$ for $t = 0.48$ and (a) $\Delta t = 0.1$ (b) $\Delta t = 0.01$ (c) $\Delta t = 0.001$. Would it be correct to say that $\Delta \sin t$ is *proportional to* Δt ? Explain.

3. At noon, a large tank contains 1000 liters of brine, consisting of water in which 20 kg of salt is dissolved. At 1 pm, 300 liters of the solution is removed from the tank, and 300 liters of pure water is immediately stirred into the tank to replace it. How much dissolved salt remains in the tank? [This is an easy introduction to a sequence of questions.]

4. At noon, a large tank contains 1000 liters of brine, consisting of water in which 20 kg of salt is dissolved. At 12:30 pm, 150 liters of brine is removed from the tank and replaced immediately by an equal amount of pure water. Another 150 liters is replaced at 1 pm. How much dissolved salt remains in the tank after these two replacements are made?

5. At noon, a large tank contains 1000 liters of water and 20 kg of dissolved salt. During the next hour, 300 liters of pure water are gradually introduced into the tank: At 12:06 pm, 30 liters of brine are removed and replaced by 30 liters of pure water. At 12:12 pm, 30 more liters are replaced. This process is repeated at 6-minute intervals.

t	S
0.0	20.00
0.1	19.40
0.2	
0.3	

ΔS	$\Delta S/\Delta t$	$(\Delta S/\Delta t)/S$
-0.6		

(a) Using the template shown, complete a table of predicted values for S , the amount of salt remaining at time t , for the entire hour.

(b) In the third column, create a table of differences, denoted ΔS , the proposed change in the amount of salt present in the solution. In the fourth column, calculate $\Delta S/\Delta t$. Notice that Δt is a constant. Why have these columns been shifted downward slightly?

(c) It is also meaningful to compare the rate of change of salt content to the amount of salt actually present at the start of each interval, so use the fifth column for $(\Delta S/\Delta t)/S$. What are the units for this ratio?

6. Why do you expect $\lim_{x \rightarrow a} \frac{f(x) - f(a)}{x - a}$ to have the same value as $\lim_{h \rightarrow 0} \frac{f(a+h) - f(a)}{h}$?

Mathematics 4C

1. Copper wire is being cooled in a physics experiment, which is designed to study the extent to which lowering the temperature of a metal improves its ability to conduct electricity. At a certain stage of the experiment, the wire has reached a temperature at which its conductance would increase 28.8 *mhos* for each additional degree dropped. At this moment, the temperature of the wire is decreasing at 0.45 degree per second. At what rate — in *mhos* per second — is the conductance of the wire increasing at this moment?

2. A ratio of changes $\frac{f(t + \Delta t) - f(t)}{\Delta t}$ is called a *difference quotient*, and the process of evaluating limits of difference quotients is often called *differentiation*. Employ differentiation to find the velocity of an object that moves along the x -axis according to the equation $x = f(t) = 4t - t^2$. Use this derivative to find the velocity and speed of the object each time that it passes the point $x = 0$.

3. (Continuation) The equation $f'(t) = 4 - 2t$ is sometimes expressed $\frac{dx}{dt} = 4 - 2t$. This illustrates the *Leibniz notation* for derivatives. After you explain why Δx is a good name for $\Delta f = f(t + \Delta t) - f(t)$, write an equation involving a limit that relates $\frac{dx}{dt}$ and $\frac{\Delta x}{\Delta t}$. This should help you understand what Leibniz had in mind.

4. Multiply out the product $(\sqrt{a} + \sqrt{b})(\sqrt{a} - \sqrt{b})$. Use the result to help you find a slope formula for $y = \sqrt{x}$.

5. (Continuation) Does the derivative of the square-root function defined by $f(x) = \sqrt{x}$ conform to the pattern already noticed for other power functions?

6. Let $A = (\cos t, \sin t)$ represent an object moving counterclockwise at 1 unit per second on the unit circle. During a short time interval h , the object moves from A to B . To build a segment that represents $\Delta \tan t$, a new type of projection is needed (recall that \sin and \cos were analyzed using projection onto the coordinate axes). Thinking of it as a *wall*, draw the line that is tangent to the unit circle at $D = (1, 0)$, then project A and B *radially* onto P and Q , respectively. In other words, OAP and OBQ are straight. As t increases from 0 to $\frac{1}{2}\pi$, P moves up the wall. Mark C on segment BQ so that segments AC and PQ are parallel. Now explain

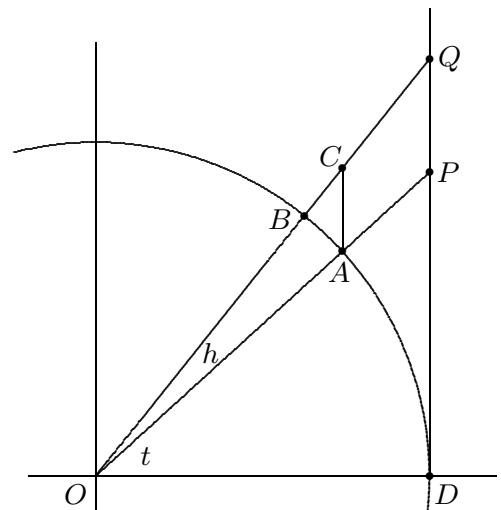

(a) why $P = (1, \tan t)$ and $Q = (1, \tan(t + h))$; (b) why $PQ = \Delta \tan(t)$; (c) why chord AB is slightly less than arc AB , which is h ; (d) why angle CAB is $t + \frac{1}{2}h$; (e) why $AC \approx h \sec(t + \frac{1}{2}h)$; (f) why $OP = \sec t$; and (g) why $PQ \approx h \sec(t + \frac{1}{2}h) \sec t$.

By letting $h \rightarrow 0$, find the derivative of the tangent function, which relates $\Delta \tan(t)$ to Δt .

7. (Continuation) What does your answer say about the slopes of the graph $y = \tan x$?

Mathematics 4C

1. Use the algebra of difference quotients to find a formula for the derivative of the power function defined by $R(x) = x^{-1} = \frac{1}{x}$. You should find that all values of $R'(x)$ are negative. What does this tell you about the graph of $y = \frac{1}{x}$?
2. *Some important limits.* You have seen that the value of $\lim_{h \rightarrow 0} \frac{\sin h}{h}$ is 1. Show that this result can be interpreted as the answer to a tangent-line question for a certain graph. Then consider the problem of showing that the value of $\lim_{h \rightarrow 0} \frac{\cos(h) - 1}{h}$ is 0. Find more than one way to obtain this result.
3. A large tank contains 1000 liters of brine, which consists of water in which 20 kg of salt have been dissolved. Choose a large positive integer n , and consider the following scenario: At n times between noon and 1 pm (every $60/n$ minutes, or $1/n$ hour), $300/n$ liters of brine are removed, replaced immediately with $300/n$ liters of pure water. After the n^{th} replacement (near 1 pm), how many kg of dissolved salt remain in the tank?
4. (Continuation) A tank contains 1000 liters of brine. Pure water is run continuously into the tank at the rate of 300 liters per hour, and brine runs continuously out of the tank at the same rate. At noon, the brine contained 20 kg of dissolved salt. At 1 pm, how many kg of salt remain in the tank?
5. (Continuation) Calculate $e^{-0.3}$, and explain its significance to the preceding problem.
6. (Continuation) Refer to the continuous model described above, and let $S(t)$ denote the number of kg of salt that remain in the tank at time t , where t is measured in hours. You have seen that $S(1) = 20e^{-0.3}$. Can you find a formula for $S(t)$ that is accurate for other values of t ? Discuss the equation $S'(t) = -0.3S(t)$, and explain how it describes the replacement process.
7. (Continuation) The continuous dilution model $S(t) = 20e^{-0.3t}$ implies that salt is being removed from the tank at an instantaneous rate of 30% per hour. It could also be said that the *instantaneous percent rate of change* is -30 . Given that $S(1) = 0.741S(0)$, what is the average hourly rate of change, and what is the *average hourly percent rate of change*?
8. A driver was overheard saying “My trip to New York City was made at 80 kilometers per hour.” Do you think the driver was referring to an *instantaneous* speed or an *average* speed? What is the difference between these two concepts?
9. (Continuation) Let $R(t)$ denote the speed of the car after t hours of driving. Assuming that the trip to New York City took exactly five hours, draw a careful graph of a plausible speed function R . It is customary to use the horizontal axis for t and the vertical axis for R . Each point on your graph represents information about the trip; be ready to explain the story behind your graph. In particular, the graph should display reasonable maximum and minimum speeds.

Mathematics 4C

- Every student of calculus ought to know that $\sin(\alpha+\beta)$ and $\sin(\alpha)\cos(\beta)+\sin(\beta)\cos(\alpha)$ are equivalent expressions. Among other things, this useful identity can be applied to give a new demonstration that the value of $\lim_{h \rightarrow 0} \frac{\sin(t+h) - \sin(t)}{h}$ is $\cos(t)$. Show how. By the way, if the angle-addition identity had not been provided, where could you have found it?
- The salt content of a tank is described by $S(t) = 20e^{-0.3t}$, or $S(t) = 20(0.741)^t$. Recall that -30 is the instantaneous percent rate of change, and that -25.9 is the average percent rate of change. What would the equations have been if the average percent rate of change had been only -8 ?
- Calculate the slope of the curve $y = x^2$ at the point $(3, 9)$ and the slope of the curve $x = y^2$ at the point $(9, 3)$. There is a simple relationship between the answers, which could have been anticipated (perhaps by looking at the graphs themselves). Explain. Illustrate the same principle with two more points on these curves, this time using a second-quadrant point on $y = x^2$.
- (Continuation) You have shown that the slope of the curve $y = x^3$ at the point $(2, 8)$ is 12. Use this result (and very little calculation) to find the slope of the curve $x = y^3$ at the point $(8, 2)$. Justify your answer.
- (Continuation) You have shown that the slope of the curve $y = e^x$ at the point (a, b) is b . Use this result to find the slope of the curve $y = \ln x$ at the point (b, a) . In other words, what is $\ln'(b)$?
- An object travels counterclockwise at 1 unit per second around the unit circle. Find components for the *velocity vector* at the instant when the object is at the point
(a) $(1, 0)$ (b) $(0, 1)$ (c) $(0.6, 0.8)$ (d) $(\cos \theta, \sin \theta)$
- (Continuation) Tethered by a string of unit length, an object is spun around in a circle, at a speed of 10 units per second. Find components for the velocity vectors at the same four points. Write parametric equations for this motion. What would happen to the object if the string broke just as the object was reaching the point $(0.6, 0.8)$?
- The point $(7.23, 0.812)$ is on the graph of $y = \sin(x)$, and the slope at this point is 0.584. What is the slope of the graph $y = \sin(3x)$ at the point $(2.41, 0.812)$?
- (Continuation) The point (a, b) is on the graph of $y = \sin(x)$, and the slope at this point is some number m . What is the slope of the graph $y = \sin(3x)$ at the point $(\frac{a}{3}, b)$?
- (Continuation) What is the slope of the curve $y = \sin(3x)$ at the point where $x = a$?
- Find a function f that fits the description $\frac{df}{dt} = f$. There are many from which to choose.

Mathematics 4C

1. Consider the graph $y = \ln x$. Because you now know the slope formula $\frac{dy}{dx} = \frac{1}{x}$, you know that $\frac{1}{2}$ is the slope of this curve at the point where $x = 2$. Notice that the Leibniz notation can be clumsy when you try to refer to specific slopes, however. For example, compare $\left. \frac{dy}{dx} \right|_{x=2}$ with the more concise $\ln'(2)$. Replace $\left. \frac{dy}{dx} \right|_{x=a}$ by a simpler expression.
2. Use a limit of difference quotients to find a formula for the derivative of the power function defined by $Q(x) = \frac{1}{x^2}$. Does your result conform to the pattern established by the derivatives of other power functions?
3. (Continuation) By examining the graphs $y = Q(x)$ and $y = Q(x - 5)$, explain how the derivative of $P(x) = \frac{1}{(x - 5)^2}$ can be obtained in a simple way from the derivative of Q . Making up your own examples, find derivatives of similarly constructed functions.
4. (Continuation) Given a function f and a constant c , determine a general relationship between the derivative of f and the derivative of $g(x) = f(x - c)$.
5. Find the values of the expressions $\lim_{h \rightarrow 0} \frac{e^h - 1}{h}$ and $\lim_{k \rightarrow 1} \frac{\ln k}{k - 1}$. Show that each value can be interpreted as a slope.
6. Find a function f that fits the description $f'(t) = -0.42f(t)$. There are many from which to choose.
7. *Linear approximation.* Find an approximate value for $F(2.3)$, given only the information $F(2.0) = 5.0$ and $F'(2.0) = 0.6$. Then explain the title of this problem.
8. Given a function f and a constant k , let $g(t) = kf(t)$. Using the definition of the derivative, explain why $g'(t) = kf'(t)$.
9. If the point (a, b) is on the graph $y = f(x)$, and if the slope at this point is some number m , then what is the slope of the graph $y = f(kx)$ at the point $\left(\frac{a}{k}, b\right)$?
10. (Continuation) Given that m is the slope of the graph $y = f(x)$ at its y -intercept, what is the slope of the graph $y = f(kx)$ at its y -intercept?
11. Illuminated by the parallel rays of the setting Sun, Andy rides alone on a merry-go-round, casting a shadow that moves back and forth on a wall. The merry-go-round takes 9 seconds to make one complete revolution, Andy is 24 feet from its center, and the Sun's rays are perpendicular to the wall. Let N be the point on the wall that is closest to the merry-go-round. Interpreted in radian mode, $f(t) = 24 \sin \frac{2\pi t}{9}$ describes the position of the shadow relative to N . Explain. Calculate the speed (in feet per second) of Andy's shadow when it passes N , and the speed of the shadow when it is 12 feet from N .

Mathematics 4C

1. The slope of the curve $y = \tan x$ is 2 at exactly one point P whose x -coordinate is between 0 and $\frac{1}{2}\pi$. Let Q be the point where the curve $y = \tan^{-1} x$ has slope $\frac{1}{2}$. Find coordinates for both P and Q . How are these coordinate pairs related?

2. A quadratic function F is defined by $F(x) = ax^2 + bx + c$, where a , b , and c are constants, and a is nonzero. Find the derivative of F . Then find the value of x that makes $F'(x) = 0$. The corresponding point on the graph $y = F(x)$ is special. Why?

3. The diagram at right shows the shadow PQ that is cast onto a wall by a six-foot person AB , who is illuminated by a spotlight on the ground at L . The distance from the light to the wall is $LP = 50$ feet, and the distance from the light to the person is $LA = x$, a variable quantity. The length of the shadow depends on x , so call it $S(x)$.

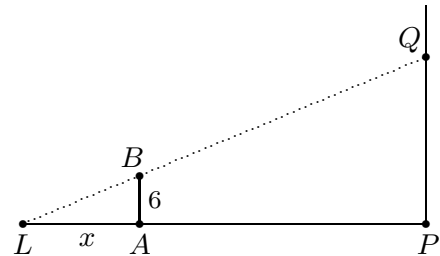

(a) Use geometry to find an explicit formula for $S(x)$.

(b) For what values of x does $S(x)$ make sense? (In other words, find the *domain* of S .)

(c) Explain why it makes sense to say that $S(x)$ is a *decreasing function* of x .

4. (Continuation) Find $\Delta S/\Delta x$ when $x = 12$ and $\Delta x = 0.4$, $\Delta x = 0.04$, and $\Delta x = 0.004$. Notice that $\Delta S/\Delta x$ is approximately constant when Δx is close to 0. What is the limiting value of $\Delta S/\Delta x$ as Δx approaches 0?

5. (Continuation) Suppose that $x(t) = 4t$, suggesting that the person is walking toward the wall at 4 feet per second. This means that the length of the shadow is also a function of time, so it makes sense to write $y(t) = S(x(t))$. Calculate $\Delta x/\Delta t$ and $\Delta y/\Delta t$ when $t = 3$ and $\Delta t = 0.1$, $\Delta t = 0.01$, and $\Delta t = 0.001$. What do you notice?

6. (Continuation) Leibniz notation and your calculations suggest that $\frac{dx}{dt}$, $\frac{dy}{dx}$, and $\frac{dy}{dt}$ should be related in a simple way. Explain.

7. (Continuation) Write an equation that connects the rates $x'(3)$, $S'(12)$, and $y'(3)$. Notice that the primes in this list of derivatives *do not all mean the same thing*. Explain.

8. (Continuation) Suppose that the person runs toward the wall at 20 feet per second. At what rate, in feet per second, is the shadow length decreasing at the instant when $x = 12$?

9. Calculate derivatives for $A(r) = \pi r^2$ and $V(r) = \frac{4}{3}\pi r^3$. The resulting functions A' and V' should look familiar. Could you have anticipated their appearance?

10. Each of the following represents a derivative. Use this information to evaluate each limit by inspection:

(a) $\lim_{h \rightarrow 0} \frac{(x+h)^7 - x^7}{h}$ (b) $\lim_{h \rightarrow 0} \frac{1}{h} \left(\sin\left(\frac{\pi}{6} + h\right) - \sin\left(\frac{\pi}{6}\right) \right)$ (c) $\lim_{x \rightarrow a} \frac{2^x - 2^a}{x - a}$

Mathematics 4C

1. Riding a train that is traveling at 72 mph, Morgan walks at 4 mph toward the front of the train, in search of the snack bar. How fast is Morgan traveling, *relative to the ground*?
2. (Continuation) Given *differentiable* functions f and g , let $k(t) = f(t) + g(t)$. Use the definition of the derivative to show that $k'(t) = f'(t) + g'(t)$ must hold. This justifies *term-by-term differentiation*. Use this result to find the derivative of $k(t) = t^3 + 5t^2 + 7$.
3. Graph both $y = 2 \sin x$ and $y' = 2 \cos x$ for $0 \leq x \leq 2\pi$, each curve on its own system of axes (as was done on page 301). Each point of the second graph tells you something about the first graph. Explain.
4. Use one-sided limits to explain why $A(x) = |x|$ is not differentiable at $x = 0$.
5. Find the derivative of $C(x) = (x^2 + 5)^3$.
6. The angle-addition identity for $\cos(\alpha + \beta)$ can be applied to give a new demonstration that $\lim_{h \rightarrow 0} \frac{\cos(t+h) - \cos(t)}{h}$ is $-\sin t$. Show how to do it.
7. The IRS tax formula for married couples is a *piecewise-linear* function. In 1997 it was

$$T(x) = \begin{cases} 0.15x & \text{for } x \leq 41200 \\ 6180 + 0.28(x - 41200) & \text{for } 41200 < x \leq 99600 \\ 22532 + 0.31(x - 99600) & \text{for } 99600 < x \leq 151750 \\ 38698.5 + 0.36(x - 151750) & \text{for } 151750 < x \leq 271050 \\ 81646.5 + 0.396(x - 271050) & \text{for } 271050 < x \end{cases}$$

This function prescribed the tax $T(x)$ for each nonnegative taxable income x .

- (a) Graph the function T , and discuss its continuity.
 - (b) Explain why $T'(x)$ makes sense for all but four nonnegative values of x . For these four values, T is said to be *nondifferentiable*.
 - (c) Graph the derived function T' . How many different values does T' have?
8. Here are three approaches to the problem of calculating slopes for the graph $y = e^{-x}$:
 - (a) Write $y = e^{-x}$ in the form $y = b^x$ and apply a formula.
 - (b) Notice that the graphs $y = e^x$ and $y = e^{-x}$ are symmetrically placed with respect to the y -axis.
 - (c) Without using your calculator, evaluate $\lim_{h \rightarrow 0} \frac{e^{-(x+h)} - e^{-x}}{h}$.
 9. If the slope of the graph $y = f(x)$ is m at the point (a, b) , then what is the slope of the graph $x = f(y)$ at the point (b, a) ?
 10. Let $P = (a, b)$ be a point on the graph $y = x^{1/n}$, and let $Q = (b, a)$ be the corresponding point on the graph $y = x^n$, where n is a positive integer. Find the slope at P , by first finding the slope at Q . Express your answer in terms of a and n . Could you have predicted the result?

Mathematics 4C

1. Find approximate values for both $g(2.1)$ and $g(1.85)$, given that $g(2.0) = -3.5$ and
(a) $g'(2.0) = 10.0$ **(b)** $g'(2.0) = -4.2$

2. A long elastic string hangs from the ceiling, as shown. A weight attached to the free end stretches the string, and a second weight stretches it further. For each point x on the unstretched string, let $f(x)$ be its position on the lightly stretched string. For each point y on the lightly stretched string, let $g(y)$ be its position on the heavily stretched string. The composition of these two stretching functions is $k(x) = g(f(x))$. Express $k'(x)$, using f' and g' .

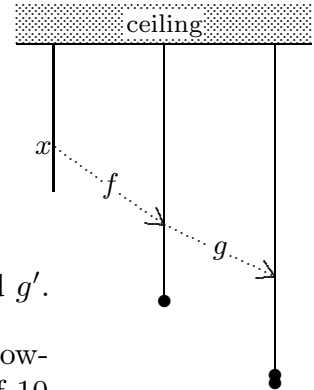

3. *Error propagation.* Ryan is taking some practice swings in slow-pitch softball. The ball is pitched so that it falls from a height of 10 feet. When the bat meets the ball, Ryan wants the axis of the bat and the center of the ball to lie in a horizontal plane that is three feet above the ground. The inclination angle θ (in radians) of the ball's trajectory will then be zero. If Ryan's bat is early or late by a small time Δt , the ball's height h (in feet) will be too high or too low at the moment of impact. The laws of physics tell us that Δh should be approximately -21.2 times Δt , and the sizes of bat and ball imply that $\Delta\theta$ is approximately 4.1 times Δh . Suppose that Ryan's bat meets the ball 0.009 second ahead of schedule (so $\Delta t = -0.009$). What is the inclination angle θ for the resulting trajectory?

4. The diagram at right shows a falling object A , which is illuminated by a streetlight L that is 30 feet above the ground. The object is 10 feet from the lamppost, and w feet below the light, as shown. Let S be the distance from the base of the lamppost to the shadow Q .

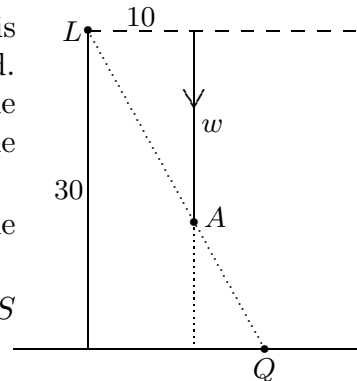

- (a)** Confirm that $S = \frac{300}{w}$ and $\frac{dS}{dw} = -\frac{300}{w^2}$. What is the significance of the minus sign in the derivative?
(b) Find ΔS when $w = 9$ and $\Delta w = 0.24$. Explain why ΔS is approximately equal to $\frac{dS}{dw} \Delta w$.

5. (Continuation) Suppose that the object was dropped from 30 feet above the ground. It follows from the laws of physics that $w = 16t^2$. Calculate w and $\frac{dw}{dt}$ when $t = 0.75$ second. Calculate Δw when $t = 0.75$ and $\Delta t = 0.01$, and notice that $\frac{dw}{dt} \Delta t \approx \Delta w$.

6. (Continuation) The distance S from Q to the lamppost is also a function of time, so it makes sense to ask for $\frac{dS}{dt}$. Calculate this velocity when $t = 0.75$ second. Confirm that $\frac{dS}{dt}$ is in fact equal to the product of $\frac{dS}{dw}$ and $\frac{dw}{dt}$, for all relevant values of t .

7. Drawn on the same system of coordinate axes, the graphs of $y = \sin x$ and $y = \tan x$ intersect in many places. Find the size of the angle formed by these curves at $(0, 0)$ and at $(\pi, 0)$.

Mathematics 4C

1. You have already investigated the limits of many difference quotients. Use these examples to explain why the expression $\frac{0}{0}$ is ambiguous (or *indeterminate*, as a mathematician would say) outside its context.

2. The function defined by $C(x) = (x^2 + 5)^3$ is an example of a composite function, meaning that it is built by substituting one function into another. One of the functions is $f(x) = x^2 + 5$ and the other is $G(x) = x^3$. First confirm that $C(x) = G(f(x))$, then confirm that $C'(x) = G'(f(x))f'(x)$. This is an example of the *Chain Rule* for derivatives. Where have you encountered it before?

3. The slope function for the line $y = mx + b$ is $\frac{dy}{dx} = m$, of course. In particular, the slope of a horizontal line $y = b$ is $\frac{dy}{dx} = 0$. This is not mysterious, but some beginning students of calculus will still have trouble writing slope formulas for the graphs $y = \ln(2)$ and $y = \sin(1.23)$. Faced with differentiating $y = \ln(2)$, Eugene said, "That's easy; the derivative is 0." Rory responded, "Zero? Isn't it $\frac{1}{2}$?" What do you think? Which expression, $\left. \frac{d \ln(x)}{dx} \right|_{x=2}$ or $\frac{d}{dx}(\ln(2))$, accurately represents the derivative of $y = \ln(2)$?

4. On the graph $y = f(x)$ shown at right, draw lines whose slopes are:

- (a) $\frac{f(7) - f(3)}{7 - 3}$ (b) $\lim_{h \rightarrow 0} \frac{f(6+h) - f(6)}{h}$
 (c) $\frac{f(7)}{7}$ (d) $\lim_{h \rightarrow 0} \frac{f(h)}{h}$

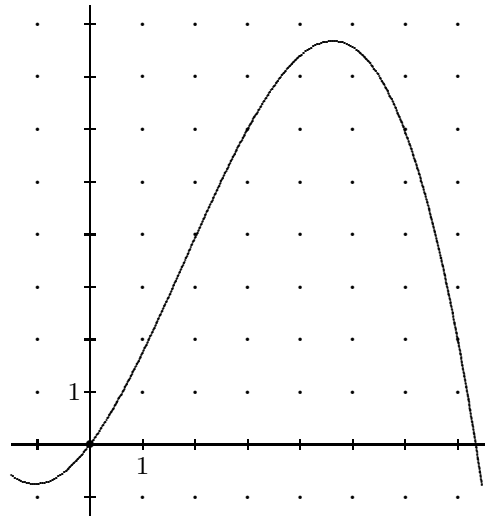

5. (Continuation) On the graph $y = f(x)$ shown, mark points where the x -coordinate has the following properties (a different point for each equation):

- (a) $\frac{f(x) - f(2)}{x - 2} = \frac{1}{2}$ (b) $\lim_{h \rightarrow 0} \frac{f(x+h) - f(x)}{h} = -1$
 (c) $\frac{f(x)}{x} = \frac{1}{2}$ (d) $\lim_{h \rightarrow 0} \frac{f(x+h) - f(x)}{h} = 0$

6. (Continuation) On a separate system of axes, graph the slope function f' .

7. Without using your calculator, find derivatives of the following:

- (a) $f(x) = x^3 + 3^x$ (b) $M(\theta) = 8 \tan(3\theta)$ (c) $H(u) = (\sin u)^3$

8. The function defined by $P(x) = x^{m/n}$ can be rewritten as a composite $P(x) = (x^{1/n})^m$. Assuming that m and n are positive integers, express $P'(x)$ in terms of x , m , and n . Could you have predicted the result?

Mathematics 4C

1. Solve the following *antiderivative* questions. In other words, find F , g , and S :

(a) $F'(x) = 4x^3$ (b) $g'(t) = 10 \cos(5t)$ (c) $\frac{dS}{du} = \frac{1}{2} e^u + \frac{1}{2} e^{-u}$

Did you notice that there is more than one correct answer to each question?

2. Given that f is a differentiable function and that the value of c does not depend on x , explain the following differentiation properties:

(a) If $g(x) = f(x - c)$, then $g'(x) = f'(x - c)$.

(b) If $g(x) = c \cdot f(x)$, then $g'(x) = c \cdot f'(x)$.

(c) If $g(x) = f(cx)$, then $g'(x) = c \cdot f'(cx)$.

Which of these differentiation properties illustrates the Chain Rule?

3. *Simple harmonic motion.* An object is suspended from a spring, 40 cm above a laboratory table. At time $t = 0$ seconds, the object is pulled 24 cm below its equilibrium position and released. The object bobs up and down thereafter. Its height y above the laboratory table is described, using radian mode, by $y = 40 - 24 \cos(2\pi t)$.

(a) What is the period of the resulting motion?

(b) Find the average velocity of the object during the first 0.5 second of motion. Find the instantaneous velocity of the object when $t = 0.25$ second. Find a way of convincing yourself that the object never moves any faster than it does at this instant.

4. Probability is useful for describing some physical processes. For example, reconsider the continuous dilution of a brine solution by running pure water through the tank *at a steady rate*. Focus your attention on a chosen salt molecule. *The nature of the dilution process* tells us that the probability that this molecule will be removed from the solution during *any* one-hour time interval is some positive constant p . The probability that it will *remain* during any one-hour interval is (of course) $q = 1 - p$.

(a) Explain why q^t is the probability that the molecule will remain in the tank during any time interval of length t hours.

(b) If there were A_0 salt molecules in the tank initially (this is an enormous number), then $A_0 q^t$ are expected to be in the tank after time t has elapsed. Explain why.

(c) Because $q < 1$, the derivative of the function defined by $A(t) = A_0 q^t$ is always negative. Explain. Thus (disregarding its sign) $A'(t)$ is the instantaneous rate of loss of the salt molecule count in the tank. Express this rate explicitly in terms of q .

(d) Divide $A'(t)$ by $A(t)$ to show that $\ln q$ is the instantaneous relative rate of change in the salt content of the tank.

(e) For example, suppose that $p = 0.2592$ and $q = 0.7408$. Both of these can be described as (average) hourly rates. Do so. Calculate the instantaneous rate of decrease of the salt content of the tank, relative to its size, and notice that this number is slightly more than p . Could this have been predicted?

5. Kyle tried to find the derivative of $y = \ln 2$ by evaluating $\lim_{h \rightarrow 0} \frac{\ln(2+h) - \ln(2)}{h}$. Will this technique yield the correct answer?

Mathematics 4C

1. An atom of carbon-14 is unstable, meaning that it can spontaneously transform itself (by radioactive decay) into nitrogen at any instant. The probability that this will actually happen to a specific atom of carbon-14 in the course of a year is only about 0.0121 percent, however. In other words, there is a 99.9879 percent chance that any specific atom of carbon-14 will survive another year. Find the probability

- (a) that this atom will last for two years without decaying into nitrogen;
- (b) that this atom will last for six months without decaying into nitrogen;
- (c) that this atom will last for y years without decaying into nitrogen.

Given an isolated amount A_0 of carbon-14, find a formula

- (d) for $A(t)$, the amount of that carbon-14 that remains after t years;
- (e) for $A'(t)/A(t)$, the instantaneous rate of change of $A(t)$, relative to $A(t)$.

Notice that your answer to part (e) is an “instantaneous” probability of decay.

2. Let $P(x) = x^{-k}$, where k is a positive rational number. Verify that the *Power Rule* applies to P . In other words, show that $P'(x) = (-k)x^{-k-1}$.

3. Find the derivative of each of the following functions:

- (a) $f(x) = x^2 + x^{-2}$
- (b) $g(t) = 3t - 5 \sin t$
- (c) $L(x) = \sqrt{4 - x^2}$
- (d) $P(t) = 12 + 4 \cos(\pi t)$

4. The function f defined by $f(x) = x^{1/3}$ is *nondifferentiable* at $x = 0$. Justify the description by explaining what the difficulty is. Find another example of a function that has the same type of nondifferentiability at a single point in its domain.

5. The slope of the curve $y = \sin x$ is $\frac{1}{2}$ at exactly one point P whose x -coordinate is between 0 and $\frac{1}{2}\pi$. Let Q be the point where the curve $y = \arcsin x$ has slope 2. Find coordinates for both P and Q .

6. Use the Power Rule to find the derivative of $Q(x) = 60 - \frac{12}{x\sqrt{x}}$.

7. Find at least two different functions W for which $W'(x) = \sqrt{x}$.

8. Let $f(x) = x^{1/3}$. Apply the algebra of difference quotients (not the Power Rule) to calculate the value $f'(8)$. (*Hint*: Recall that $a - b$ is a factor of $a^3 - b^3$.)

Mathematics 4C

1. As part of a step-by-step demonstration, a student wrote $\sin'(3x) = 3 \cos(3x)$. What do you think of this equation? What do you think that the student was trying to express?

2. Find a function that is equivalent to twice its derivative.

3. The examples $D(e^{2x}) = 2e^{2x}$ and $D \sin = \cos$ illustrate another notation for derivatives, known as *Heaviside's operator notation*. The letter D is read "the derivative of ...". Optional subscripts occasionally appear, as in $D_x(x^2 - 4x) = 2x - 4$. Thus D_x is just the Leibniz operator $\frac{d}{dx}$, meaning "the derivative, with respect to x , of ...". Subscripts are actually necessary at times. For instance, show by calculation that $D_x(x^u)$ and $D_u(x^u)$ are not equivalent.

4. To prove that $\lim_{n \rightarrow \infty} \left(1 + \frac{x}{n}\right)^n$ is e^x , you can begin by writing $\lim_{n \rightarrow \infty} \left[\left(1 + \frac{1}{n/x}\right)^{n/x}\right]^x$. Show that this is equivalent to $\lim_{m \rightarrow \infty} \left[\left(1 + \frac{1}{m}\right)^m\right]^x$. Why is it important that x be *positive*?

5. (Continuation) To explore the truth of $\lim_{n \rightarrow \infty} \left(1 + \frac{x}{n}\right)^n = e^x$ for *negative* values of x , first examine the special case $x = -1$. Rewrite $\lim_{n \rightarrow \infty} \left(1 - \frac{1}{n}\right)^n$ as $\lim_{n \rightarrow \infty} \left(\frac{n-1}{n}\right)^n$, then make the substitution $n = m + 1$. If the result is not familiar, consider a reciprocal.

Euler's formula states that $e^{i\theta} = \cos \theta + i \sin \theta$, which is why one often sees $e^{i\theta}$ instead of $\text{cis } \theta$ in Calculus books. The next five items establish the equivalence of these formulas in the special case $\theta = 1$. (The general case is done similarly.) In the following, n is a positive integer. Recall that $|a + bi|$ means $\sqrt{a^2 + b^2}$, the *magnitude* of the complex number $a + bi$, and that DeMoivre's Theorem says that the polar angle of $(a + bi)^n$ is n times the polar angle of $a + bi$.

6. Verify that $\left|1 + \frac{i}{n}\right| = \sqrt{1 + \frac{1}{n^2}}$, then explain why $\left|\left(1 + \frac{i}{n}\right)^n\right| = \left(1 + \frac{1}{n^2}\right)^{n/2}$.

7. The polar angle of $1 + \frac{i}{n}$ is $\arctan \frac{1}{n}$, and the polar angle of $\left(1 + \frac{i}{n}\right)^n$ is $n \arctan \frac{1}{n}$. Justify these two statements.

8. Justify $\left(1 + \frac{1}{n^2}\right)^{n/2} = \left[\left(1 + \frac{1}{n^2}\right)^{n^2}\right]^{1/(2n)}$, then evaluate $\lim_{n \rightarrow \infty} \left(1 + \frac{1}{n^2}\right)^{n/2}$.

9. Justify the equation $n \arctan \frac{1}{n} = \frac{\arctan(1/n) - \arctan(0)}{1/n}$. Thus $\lim_{n \rightarrow \infty} n \arctan \frac{1}{n}$ can be interpreted as the calculation of a derivative. Evaluate the limit.

10. Use the preceding results to show that $\lim_{n \rightarrow \infty} \left(1 + \frac{i}{n}\right)^n$ is $\cos 1 + i \sin 1$.

Mathematics 4C

1. Interpret the diagram as a *velocity-time* graph for an object that is moving along a number line. The horizontal axis represents time (seconds) and the vertical axis represents velocity (meters per sec).

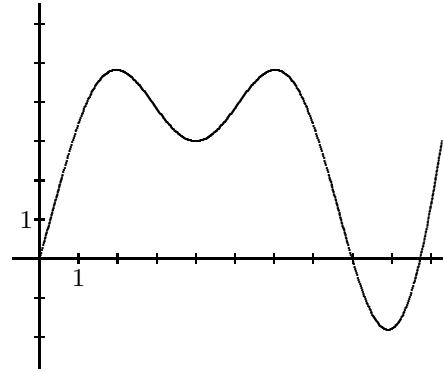

(a) The point $(9.0, -1.8)$ is on the graph. Find it in the diagram and describe what is going on. In particular, what is the significance of the sign? Choose three other conspicuous points on the graph and interpret them.

(b) Suppose that the object starts its journey when $t = 0$ at a definite point P on the number line. Use the graph to estimate the position of the object (in relation to P) 2 seconds later.

2. (Continuation) On a separate system of axes, sketch the derivative of the velocity function whose graph appears above. Interpret your graph in this context.

3. Let $f(x) = x^3$, $g(x) = x^4$, and $k(x) = x^7$. Notice that $k(x) = f(x) \cdot g(x)$. Is it true that $k'(x) = f'(x) \cdot g'(x)$, however?

4. Solve the following *antiderivative* questions. In other words, find W , S , F , and g .

(a) $W'(x) = x^{42}$ (b) $\frac{dS}{du} = 2u(7 + u^2)^{42}$ (c) $F'(u) = 2u$ (d) $g'(t) = 2 \sin t \cos t$

5. What is the cosine of the first-quadrant angle whose (a) sine is 0.352? (b) sine is k ?

6. (Continuation) Explain the equivalence of $\cos(\arcsin x)$ and $\sqrt{1 - x^2}$.

7. (Continuation) On the same system of coordinate axes, and using the same scale on both axes, make careful graphs of both $y = \sin x$ and $y = \arcsin x$. These graphs should intersect only at the origin. Let $P = (a, b)$ be a point on the graph of $y = \arcsin x$, and let $Q = (b, a)$ be the corresponding point on the graph of $y = \sin x$. Find the slope at P , by first finding the slope at Q . Use the preceding to express your answer in terms of a .

8. Consider the well-known formula $V = \pi r^2 h$ for the volume of a cylinder. This expresses V as a function of r and h . Calculate $\frac{dV}{dr}$ and $\frac{dV}{dh}$. What assumptions did you make? Interpret each derivative geometrically (*making appropriate diagrams*). In particular, explain the geometrical content of the approximation $\Delta V \approx \frac{dV}{dr} \cdot \Delta r$ and the equation $\Delta V = \frac{dV}{dh} \cdot \Delta h$. Explain why one equation is exact and the other is only an approximation.

9. There are many functions f for which $f(3) = 4$ and $f'(3) = -2$. The only linear example is $f(x) = 10 - 2x$, and $f(x) = 7 - \frac{1}{3}x^2$ is one of the quadratic examples. Find a different quadratic example.

Mathematics 4C

1. Kelly is using a mouse to enlarge a rectangular frame on a computer screen. As shown at right, Kelly is dragging the upper right corner at 2 cm per second horizontally and 1.5 cm per second vertically. Because the width and height of the rectangle are increasing, the enclosed area is also increasing. At a certain instant, the rectangle is 11 cm wide and 17 cm tall. By how much does the area increase during the next 0.1 second? Make calculations to show that most of the additional area comes from two sources — a contribution due solely to increased width, and a contribution due solely to increased height. Your calculations should also show that the rest of the increase is insignificant — amounting to less than 1%.

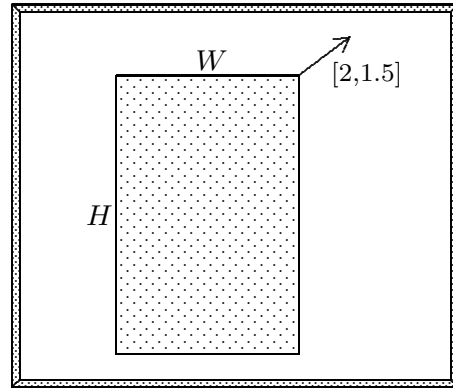

2. (Continuation) Repeat the calculations, using a time increment of 0.001 second. As above, part of the increase in area is due solely to increased width, and part is due solely to increased height. What fractional part of the change is not due solely to either effect?
3. (Continuation) Let $A(t) = W(t) \cdot H(t)$, where A , W , and H stand for area, width, and height, respectively. The previous examples illustrate the validity of the equation $\Delta A = W \cdot \Delta H + H \cdot \Delta W + \Delta W \cdot \Delta H$, in which the term $\Delta W \cdot \Delta H$ plays an insignificant role as $\Delta t \rightarrow 0$. Divide both sides of this equation by Δt and calculate limits, thus showing that the functions $\frac{dA}{dt}$, W , H , $\frac{dW}{dt}$, and $\frac{dH}{dt}$ are related in a special way. This relationship illustrates a theorem called the *Product Rule*.
4. Apply the Product Rule to an example of your choosing.
5. The equation $y = 0.01 \cos(400\pi t) \sin(\pi x)$ is one possible model for the motion of a stretched string that is 1 foot long and that is vibrating 200 times per second. The small number 0.01 is the *amplitude* (in feet) of the oscillation. Choosing a t -value is equivalent to taking a snapshot of the string, which is defined for x -values from 0 to 1, inclusive ($x = 0$ is one end of the string and $x = 1$ is the other end).
- (a) How far does the center of the string move during one complete vibration?
- (b) What is the average speed of the center of the string during the interval $0 \leq t \leq 0.005$? What is the average velocity?
- (c) Does the center of the string move with constant velocity? With constant speed?
- (d) Calculate $D_t y$ for the center of the string.
- (e) Calculate $D_t y$ for the point on the string where $x = \frac{1}{4}$.
6. With the help of the Chain Rule and the Power Rule, it is straightforward to write out the derivative of an example such as $f(x) = (\sin x)^{1/2}$. Do so, and then consider the generic example of this type, which has the form $f(x) = (g(x))^n$.

7. Find $\frac{dy}{dx}$ for each of the following functions:

- (a) $y = x \cdot \sin x$ (b) $y = x^2 \cdot \ln x$ (c) $y = \sin x \cos x$ (d) $y = x\sqrt{4 - x^2}$

Mathematics 4C

1. As shown at right, the parabolic arc $y = 7 - x - x^2$ for x in $[-3.5, 1]$ has been joined smoothly at $(1, 5)$ to another parabolic arc $y = a(x - c)^2$ for x in $[1, 6]$. Notice the use of *interval notation*, which is common in many calculus books. Find the values of a and c . You will need to decide what the word “smoothly” means in this context.

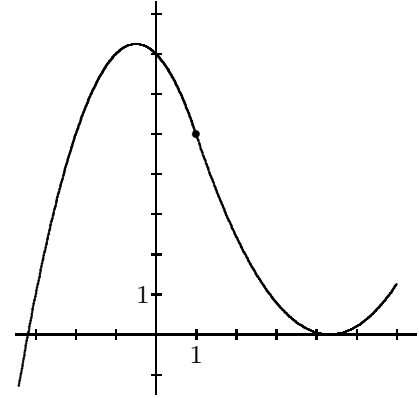

2. The function \tan^{-1} is sometimes called arctan, for good reasons. For instance, the name \tan^{-1} is easily misinterpreted — explain. It is also easy to see that it is awkward to use the name \tan^{-1} in conjunction with the prime notation for derivatives — just compare the readability of $(\tan^{-1})'$ with \arctan' . On the other hand, operator notation for derivatives allows you to avoid this difficulty — you can write expressions like $\frac{d}{dx} \tan^{-1}$ or $D \tan^{-1}$ if you want. Whatever name you prefer for the inverse tangent function, however, obtain a *formula* for its derivative, and simplify it as much as possible. As happened with the derivative of arcsin, you can eliminate all references to sin, cos, and tan from your answer.

3. Given that $R'(t) = k \cdot R(t)$ and $R(0) = 3960$, find $R(t)$.

4. *Implicit differentiation.* Apply D_x to both sides of the circle equation $x^2 + y^2 = 1$. In other words, calculate $D_x(x^2 + y^2)$, thinking of y as an *implicitly defined function of x* , and set the result equal to $D_x 1$. The new equation involves $D_x y$ as well as x and y . Solve for $D_x y$. Contrast this approach with other methods of obtaining $D_x y$ for the unit circle.

5. On the graph $y = f(x)$ shown at right, draw lines whose slopes are:

(a) $\frac{f(7) - f(3)}{7 - 3}$ (b) $\lim_{x \rightarrow 6} \frac{f(x) - f(6)}{x - 6}$
 (c) $\frac{f(7)}{7}$ (d) $\lim_{h \rightarrow 0} \frac{f(h)}{h}$

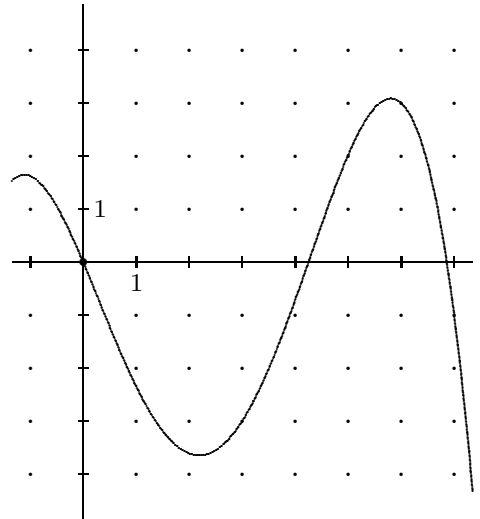

6. (Continuation) On the graph $y = f(x)$ shown, mark points where the x -coordinate has the following properties (a different point for each equation):

(a) $\frac{f(x) - f(3)}{x - 3} = -1$ (b) $\lim_{h \rightarrow 0} \frac{f(x+h) - f(x)}{h} = -1$
 (c) $\frac{f(x)}{x} = \frac{1}{2}$ (d) $\lim_{w \rightarrow x} \frac{f(w) - f(x)}{w - x} = 0$

7. Let $f(x) = x\sqrt{4 - x^2}$. Then f is continuous on the interval $[-2, 2]$, but differentiable only on the interval $(-2, 2)$. Explain this remark.

Mathematics 4C

1. There are many functions f for which $f(3) = 4$ and $f'(3) = -2$. A quadratic example is $f(x) = x^2 - 8x + 19$. Find an example of the exponential form $f(x) = a \cdot b^x$.
2. Find equations for two of the lines that are tangent to the graph $y = \ln x$; one at $(e^2, 2)$, and the other at $(2, \ln 2)$.
3. Calculate the derivative of each of the following functions:
 (a) $f(t) = t^2 e^{-t}$ (b) $g(u) = u^2 \sqrt{u}$ (c) $M(x) = 2^{\sin x}$ (d) $R(t) = \cos \sqrt{t}$
4. Suppose that an object is moving along a number line so that its position at time t seconds is $f(t) = t^3 - 9t^2 + 15t + 9$.
 (a) What is the *velocity* of the object at time t ?
 (b) For what values of t is the object moving in the positive direction? In other words, for what values of t is $f(t)$ *increasing*?
 (c) For what values of t is $f(t)$ *decreasing*?
 (d) *When* does the object reverse its direction? *Where* do these reversals take place?
 (e) Find the *average velocity* of the object during the time interval $1 \leq t \leq 5$. Find the *average speed* of the object during this interval, and the *greatest speed* the object attains.
5. Simplify $\frac{f(t+1) - f(t)}{f(t)}$ in the situation where $f(t) = Ab^t$. What does this expression mean if f models population growth?
6. (Continuation) Simplify $\frac{f(t+h) - f(t)}{h} \cdot \frac{1}{f(t)}$ in the situation where $f(t) = Ab^t$. What does this expression mean if f models population growth?
7. (Continuation) Suppose that $f(t) = Ab^t$ models population growth. Show that the equation can be rewritten $f(t) = Ae^{mt}$. How is m related to b ? What are the meanings of A , b , m , and $\frac{f'(t)}{f(t)}$ in this model?
8. Use implicit differentiation to find the slope of the ellipse $9x^2 + y^2 = 225$ at $(4, 9)$. In other words, find $\frac{dy}{dx}$ without first trying to solve for y as an explicit function of x .

9. As shown below, an 8×15 rectangular sheet of metal can be transformed into a rectangular box by cutting four congruent squares from the corners and folding up the sides. The volume $V(x)$ of such a box depends on x , the size of the cutouts.

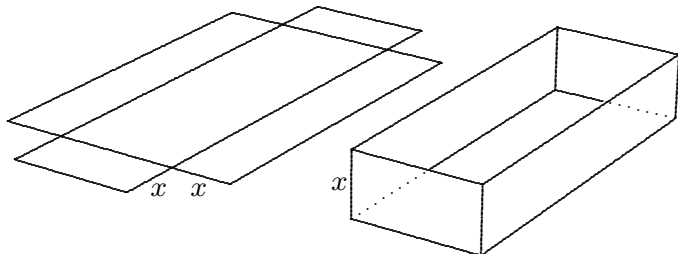

- (a) Show that $V(x) = 4x^3 - 46x^2 + 120x$. For what values of x does $V(x)$ make sense?
- (b) Show that $0 < \Delta V$ when $x = 1.5$ and $\Delta x = 0.1$, and that $\Delta V < 0$ when $x = 2.0$ and $\Delta x = 0.1$. What does this data suggest?
- (c) Show how to use $V'(x)$ to find the largest value of $V(x)$.

Mathematics 4C

1. The figure below shows the graph of $y = f(x)$, where f is a differentiable function. The points P , Q , R , and S are on the graph. At each of these points, determine which of the following statements applies:

- (a) f' is positive (b) f' is negative (c) f is increasing
(d) f is decreasing (e) f' is increasing (f) f' is decreasing

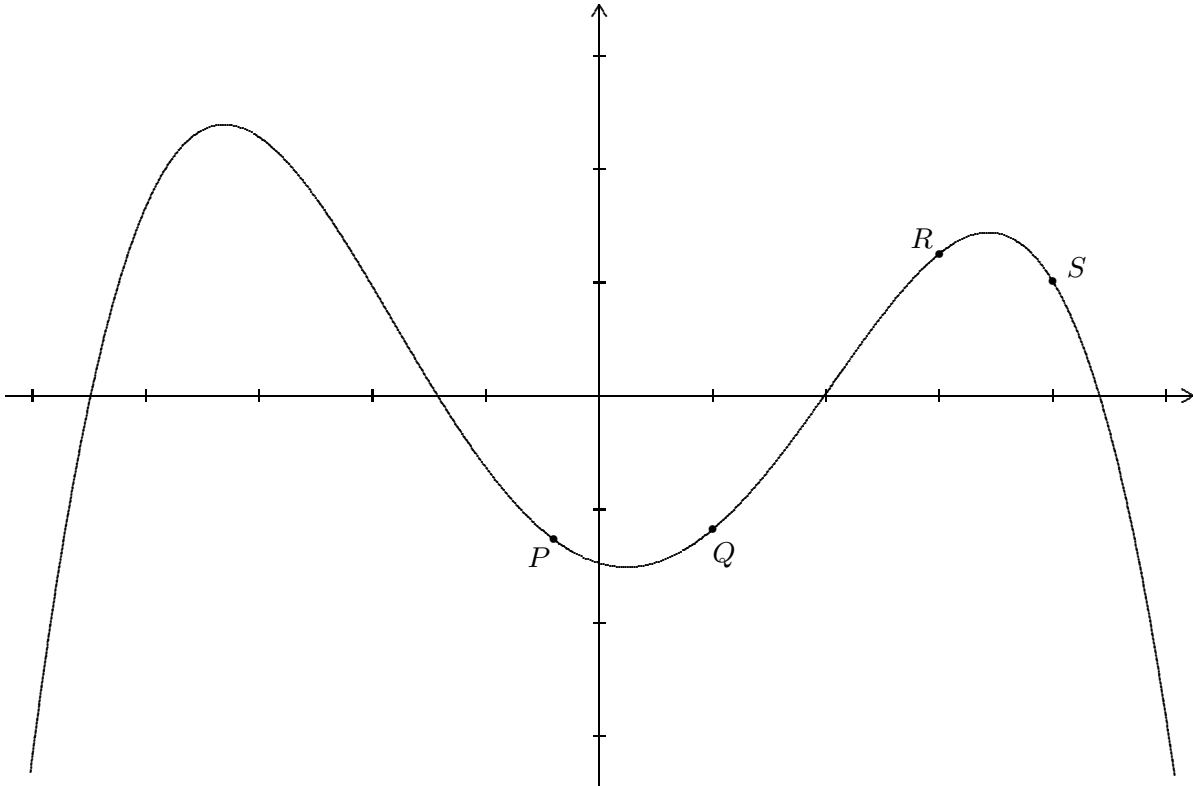

The graph $y = f(x)$ is called *concave up* at points P and Q , and it is called *concave down* at points R and S .

2. A potato, initially at room temperature (70 degrees), is placed in a hot oven (350 degrees) for thirty minutes. After being taken out of the oven, the potato sits undisturbed for thirty more minutes on a plate in the same room (70 degrees). Let $F(t)$ be the temperature of the potato at time t during the 60-minute time interval $0 \leq t \leq 60$. On separate axes, draw plausible graphs of both F and F' . Other than $F(0)$, you are not expected to know any specific values of F .

3. You have shown that the derivative of $R(t) = \frac{1}{g(t)} = [g(t)]^{-1}$ is $R'(t) = -\frac{g'(t)}{[g(t)]^2}$, with the help of the *Chain Rule*. Now try to find a general *Quotient Rule* that deals with functions of the form $Q(t) = \frac{f(t)}{g(t)}$. A good way to start is to rewrite the preceding as $Q(t) = f(t) \cdot \frac{1}{g(t)}$. Express your answer in the form $\frac{\text{numerator}(t)}{\text{denominator}(t)}$.

Mathematics 4C

1. Consider the circle given by $(x - 1)^2 + (y + 3)^2 = 25$. The slope of the tangent line at a point (x, y) on this curve is a function of both x and y . Find a formula for this function, and use it to find the tangent slope at $(4, 1)$, $(1, -8)$, and $(-3, 0)$.

2. Derivatives can sometimes be found with little effort. The bowl shown in the figure is 3 feet deep, and is situated so that its octagonal opening is parallel to the ground. Its volume is 125 cubic feet. The water in it is being siphoned out at a steady rate of 20 cubic feet per minute. After t minutes, let V be the volume of water in the bowl, y be the depth of the water, and A be the area of the water surface. You are given the information

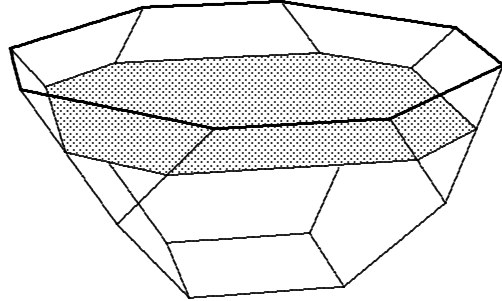

$\frac{dV}{dt} = -20$, and the goal is to find $\frac{dy}{dt}$, *without* finding y as an explicit function of t .

(a) If $\frac{dy}{dt}$ were constant, it would be a simple matter to calculate its value. How? What would the value of this rate be?

(b) Referring to the figure, briefly explain why $\frac{dy}{dt}$ is not constant.

(c) Let t be the instant when $A = 30$ square feet. During the next 0.2 minute, how much water leaves the bowl? Use this number, and a little mental computation, to explain why the depth y decreases by slightly more than $2/15$ foot during this 0.2-minute interval.

(d) Replace $\Delta t = 0.2$ by a much smaller value, and revise your estimate of Δy .

(e) The actual value of $\frac{dy}{dt}$ at the instant when $A = 30$ should now be clear. It should also be clear how to calculate $\frac{dy}{dt}$ quickly whenever the value of A is known.

3. Find $\frac{dy}{dx}$ for each of the following curves:

(a) $y = \frac{x-1}{x+1}$ (b) $y = \frac{\sin x}{\cos x}$ (c) $y = \frac{42}{x^2}$ (d) $y = \frac{\sqrt{x}}{x}$ (e) $y = \frac{x}{x^2+1}$

4. There are many functions f with $f(3) = 4$ and $f'(3) = -2$. The exponential example is $f(x) = 4e^{(3-x)/2}$, and one of the sinusoidal examples is $f(x) = 4 + \frac{12}{\pi} \cos \frac{\pi x}{6}$. Find a different sinusoidal example.

5. Differentiable functions f and g are given. Find the value of $\lim_{x \rightarrow a} \frac{f(x)g(x) - f(a)g(a)}{x - a}$ by first rewriting it as $\lim_{x \rightarrow a} \frac{f(x)g(x) - f(a)g(x) + f(a)g(x) - f(a)g(a)}{x - a}$.

6. A running track, whose total length is 400 meters, encloses a region that is comprised of a rectangle and two semicircles, as shown in the diagram. What are the dimensions of the track, given that it was designed to make the area of the rectangle as large as possible?

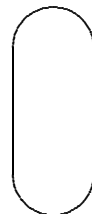

Mathematics 4C

1. Thirty feet above the ground, a tightrope \overline{AB} is stretched between two buildings that are fifty feet apart. Harley walks the tightrope cautiously from A to B , at 2 feet per second. As shown in the diagram, Harley's act is illuminated by a spotlight L that is 70 feet directly above A .

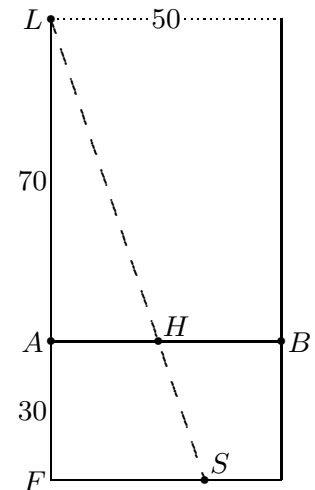

(a) Letting x stand for AH , explain why $2 = \frac{dx}{dt}$.

(b) How fast is Harley's shadow S moving along the ground when Harley is midway between the buildings? It helps to notice the simple geometric relationship between the lengths AH and FS .

(c) How far from A is Harley when the shadow reaches the base of building B ?

(d) How fast is Harley's shadow moving up the side of the building when Harley is 10 feet from B ?

2. For positive x -values, let $P(x)$ be the postage (in cents) needed to send an item that weighs x ounces first-class. The rule in July 2006 was that $P(x)$ is 39 cents for the first ounce, or fraction thereof, and 24 cents for each additional ounce, or fraction thereof. For example, $P(0.4) = 39$, $P(0.7) = 39$, and $P(2.4) = 87$. This is an example of a *step function*.

(a) Graph P and explain the terminology. Also graph P' .

(b) Describe the x -values at which P is nondifferentiable, and the x -values at which P is *discontinuous*.

(c) If n is a nonnegative integer and $n < x \leq n + 1$, then what is $P(x)$, in terms of n ?

3. Given $G(t) = b^t$ and $E(t) = e^{(\ln b)t}$, find $\frac{G'(t)}{G(t)}$ and $\frac{E'(t)}{E(t)}$.

4. Draw the graph of $y = \ln(1 - x)$. Explain why y is virtually the same as $-x$ when x is near zero.

5. The probability of a given atom decaying into another atom during a one-second interval is p , (which is usually a small positive number). The probability that the given atom will persist (not decay) during the one-second interval is therefore $q = 1 - p$. Explain how to think of $\ln q$ as an instantaneous rate. Using $\ln q = \ln(1 - p)$, explain why this rate is very nearly $-p$ when p is a small positive number.

6. Identify each of the following rules, which are expressed in Leibniz notation:

$$\frac{d}{dx}(uv) = u \frac{dv}{dx} + v \frac{du}{dx} \qquad \frac{d}{dx}(u^n) = nu^{n-1} \frac{du}{dx} \qquad \frac{d}{dx} \left(\frac{u}{v} \right) = \frac{v \frac{du}{dx} - u \frac{dv}{dx}}{v^2}$$

7. Consider lines that go through the origin $(0, 0)$ — some lines intersect the curve $y = 2^x$ at two places, some lines intersect the curve at one point, and some lines do not intersect the curve at all. There is only one line through the origin that intersects the curve $y = 2^x$ *tangentially*. Find the slope of this special line, and find coordinates for the point of tangency.

Mathematics 4C

1. The graph on the right shows how Brook's pulse (beats per minute) during a typical treadmill workout depends on the steepness of the running surface. The graph on the left shows how Brook varied the steepness during part of yesterday's workout. Use the information contained in these graphs to draw a graph that shows how Brook's pulse varied during the workout interval $0 \leq t \leq 15$. In particular, estimate Brook's pulse and how fast it was changing at **(a)** the 5-minute mark; **(b)** the 7-minute mark; **(c)** the 10-minute mark of the workout.

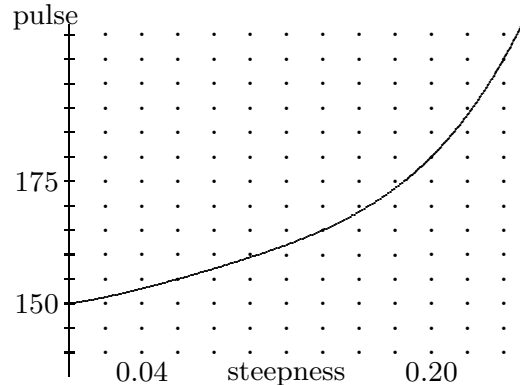
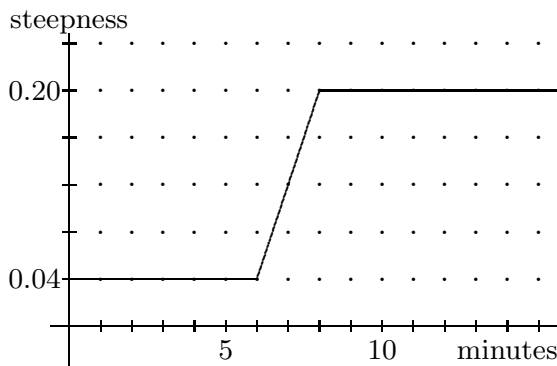

2. There are many functions f for which $f'(t) = -0.12f(t)$ is true. Find three examples.
3. An object moves along the x -axis. Its position at time t is $x = t + 2 \sin t$, for $0 \leq t \leq 2\pi$.
- What is the velocity of the object at time t ?
 - For what values of t is the object moving in the positive direction?
 - For what values of t is the object moving in the negative direction?
 - When and where does the object reverse its direction?
 - Find the average velocity during the time interval $0 \leq t \leq 2\pi$.
 - Find the average speed and the greatest speed during the time interval $0 \leq t \leq 2\pi$.
4. Consider functions of the form

$$f(x) = \begin{cases} 4 - 2|x| & \text{for } x \leq 1 \\ ax^2 + bx + c & \text{for } 1 < x \end{cases}$$

- What condition on a , b , and c guarantees that f is a continuous function?
 - What conditions on a , b , and c guarantee that f is differentiable at $x = 1$? For any such function f , the value of coefficient a determines the values of coefficients b and c ; express b and c in terms of a for such a function.
 - Find the unique function f that is differentiable at $x = 1$ and whose graph is tangent to the x -axis. Find the x -coordinate of the point of tangency.
5. Apply the technique of implicit differentiation to find $D_x y$ for the curve $x = \cos y$.
6. (Continuation) Find a formula for the derivative of $y = \arccos x$ in terms of x .
7. Express the surface area S of a sphere as a function of its volume V , then find $\frac{dS}{dV}$.

Mathematics 4C

1. The bowl shown in the figure is 3 feet deep, and is situated so that its octagonal opening is parallel to the ground. Its volume is 125 cubic feet. Left alone, the water will evaporate at a rate that is *proportional to the area of the water surface*.

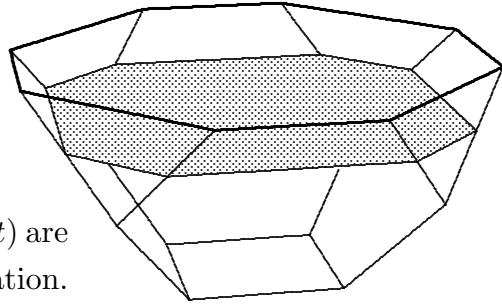

(a) Explain why this should be expected.

(b) Suppose that $\frac{dV}{dt} = -0.12A$, where $V(t)$ and $A(t)$ are the volume and surface area after t days of evaporation. In what units should the constant -0.12 be expressed?

(c) By considering what happens during short intervals of time, deduce that the water depth $y(t)$ must decrease at a *constant* rate.

(d) Given $y(0) = 3$, calculate how many days pass until evaporation empties the bowl.

2. There are many functions f for which $f(3) = 4$ and $f'(3) = -2$. One of the sinusoidal examples is $f(x) = 4 - 2\sin(x - 3)$. Find the unique power example $f(x) = ax^n$.

3. Write an equation for the line tangent to the parabola $x = 8y - y^2$ at the point $(15, 3)$.

4. Consider the equations $y'(t) = -0.12$ and $y'(t) = -0.12y(t)$. They say similar yet different things about the functions whose rates of change they are describing. For each equation, find the function that satisfies the condition $y(0) = 36$, then compare graphs of the two functions. How are they alike, and how do they differ? In what kinds of applications have you seen these functions before?

5. (Continuation) The equations $y'(t) = -0.12$ and $y'(t) = -0.12y(t)$ are *differential equations*. As the name suggests, this means that derivatives appear in the equation. It also means that the solutions to the equations are *functions*, not numbers. Roughly speaking, *each solution to a differential equation is a graph*. Moreover, a differential equation usually has *infinitely many solutions*. Confirm this. Graph two more solutions for each example.

6. A police helicopter H is hovering 1000 feet above a highway, using radar to check the speed of a red convertible C below. The radar shows that distance HC is 1250 feet and increasing at 66 feet per second. The obvious question: Is the car exceeding the speed limit, which is 65 mph? Here is how to figure out the speed of the car: Let $x = FC$, where F is the point on the highway that is directly beneath H , and let $z = HC$. Notice that x and z are both functions of t , and that $z(t)^2 = 1000^2 + x(t)^2$. Differentiate both sides of this equation with respect to t . The new equation involves $\frac{dx}{dt}$ and $\frac{dz}{dt}$ as well as x and z . The radar shows that $\frac{dz}{dt} = 66$ when $z = 1250$. Use this data to calculate $\frac{dx}{dt}$.

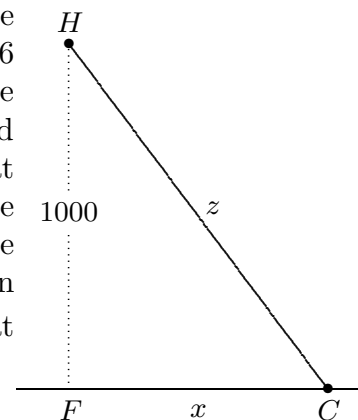

Mathematics 4C

1. Suppose that $f(x)$ is defined for $-4 \leq x \leq 4$, and that its derivative f' is shown at right. Use the information in this graph and the additional fact $f(-1) = 3$ to answer the following:

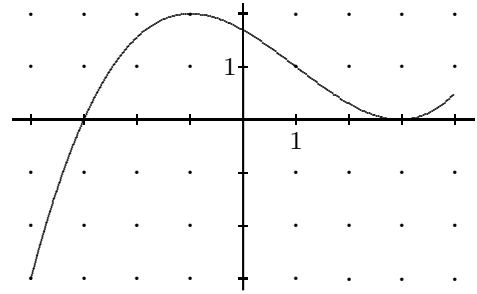

- (a) Is it possible that $f(3) \leq 3$? Explain.
- (b) Is it possible that $11 \leq f(3)$? Explain.
- (c) For what x does $f(x)$ reach its maximum value?
- (d) For what x does $f(x)$ reach its minimum value?
- (e) Estimate that minimum value, and make a sketch of $y = f(x)$ for $-4 \leq x \leq 4$.

2. Justify the equation $D(e^{it}) = ie^{it}$. Then explain why this implies that $D(\sin t) = \cos t$ and $D(\cos t) = -\sin t$. Recall that e^{it} is the calculus name for $\cos t + i \sin t$.

3. The four graphs shown below belong to f , g , f' , and g' . Figure out which is which. It is possible to devise believable formulas for these functions; try that, too.

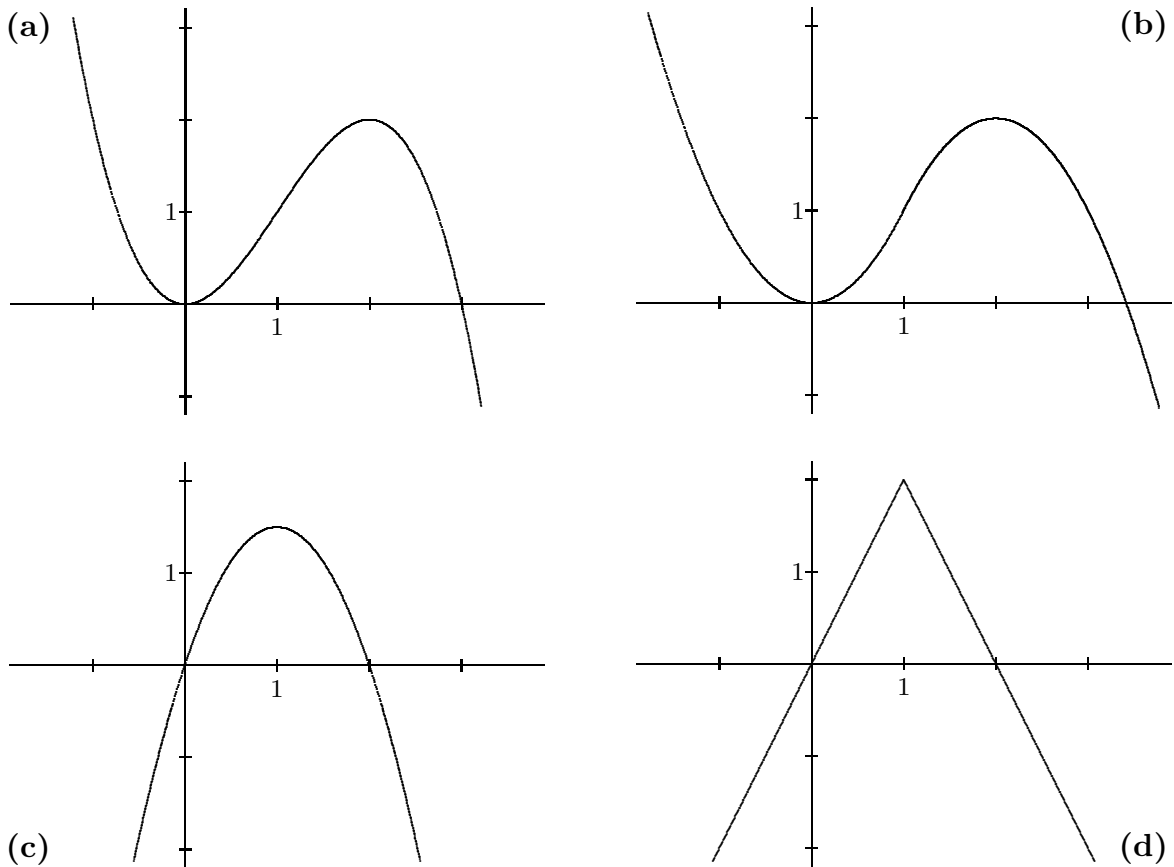

4. Let $A = (a, a^2)$ be a typical point on the parabola $y = x^2$. Find the y -intercept of the line that intersects the parabola perpendicularly at A .

5. Find $\frac{dy}{dx}$ for the function defined implicitly by $y = xy^2 + 1$.

Mathematics 4C

1. Use a derivative to confirm that $(0, 0)$ and $(2, 4)$ are *locally extreme* points on the graph of $y = 3x^2 - x^3$. Explain this terminology. Then consider the section of the curve that joins these extreme points, and find coordinates for the point on it where the slope is steepest.
2. (Continuation) A cubic graph $y = ax^3 + bx^2 + cx + d$ has either *two* locally extreme points or *none*. Explain. Give an example that illustrates the second case.
3. (Continuation) Suppose that the local extremes of $y = ax^3 + bx^2 + cx + d$ are (x_1, y_1) and (x_2, y_2) . Explain why the slope of this curve has a local extreme (a *global* extreme, in fact) when $x = \frac{1}{2}(x_1 + x_2)$.
4. Find the value of $\lim_{h \rightarrow 0} \frac{\ln(a+h) - \ln(a)}{h}$ by inspection.

5. A circular cylinder is to be inscribed in a sphere of radius 12. Find the height of that inscribed cylinder whose volume is as large as possible. Justify your choice.

6. Find derivatives: (a) $f(t) = e^{13-5t}$ (b) $g(t) = e^{\ln t}$ (c) $M(t) = e^{v(t)}$

7. The diagram shows the graph of $y = f(x)$, which can be interpreted in the following two ways:

(a) It shows the elevation during a hike along a mountain ridge, as a function of time. During the part of the hike represented by the curve that joins point A to point B, there is a moment when the hiker is working hardest. If you had a formula for the function f , how would you calculate this time?

(b) It represents a bird's-eye view of a winding road. As you drive along the section of road from point A

towards point B, there is a point where the car stops turning to the left and starts turning to the right. If you had a formula for the function f , how would you locate this point?

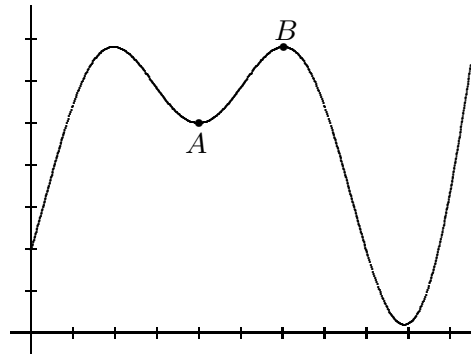

8. The volume of a cube is increasing at 120 cc per minute at the instant when its edges are 8 cm long. At what rate are the edge lengths increasing at that instant?

9. It is often useful to calculate the derivative of a derivative f' . The result is called the *second derivative of f* and denoted f'' . For each of the following, calculate f' and f'' :

(a) $f(x) = x^2 - 1$ (b) $f(z) = z \ln z$ (c) $f(u) = \cos(2u)$ (d) $f(t) = e^{-t^2}$

10. (Continuation) In example (a), notice that $f'(-1) < 0$ and $0 < f''(-1)$. What does this tell you about the graph of $y = f(x)$? Find a similar point (where f' is negative and f'' is positive) on the graph of (b).

11. (Continuation) On the graph of example (d), find all points where f' is negative and f'' is positive.

Mathematics 4C

1. If f is a function of x , the Heaviside notation for the second derivative of f is $D_x^2 f$, and the Leibniz notation is $\frac{d^2 f}{dx^2}$. Make sense out of these notations.
2. To form a rectangular box, you can first cut four x -by- x squares from the corners of an a -by- a sheet of cardboard, and then fold up the sides. For what value of x is the volume of the resulting box as large as it can be?
3. Find the acute angle formed at $(\frac{1}{4}\pi, \frac{1}{2}\sqrt{2})$ by the intersecting graphs of sine and cosine.
4. You know that $D_t e^t = e^t$ and that $D_t \ln t = \frac{1}{t}$. When bases other than e occur, you also know that $D_t b^t = b^t \ln b$. That leaves the logarithm question: what is $D_t \log_b t$?

5. Alex is in the desert in a jeep, 10 km from a long, straight road. On the road, the jeep can do 50 kph, but in the desert sands, it can manage only 30 kph. Alex is very thirsty, knows that there is a gas station 20 km down the road (from the nearest point on the road) that has ice-cold Pepsi, and decides to drive there. Alex follows a straight path through the desert, and reaches the road at a point that is between N and P , and x km from N . The total time $T(x)$ for the drive to the gas station is a function of this quantity x . Find an explicit expression for $T(x)$, then calculate $T'(x)$. Use algebra to find the minimum value of $T(x)$ and the value of x that produces it.

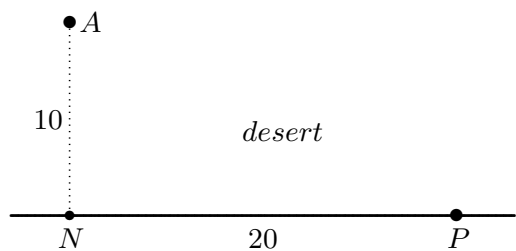

6. A particle moves along a number line according to $x = t^4 - 4t^3 + 3$, during the time interval $-1 \leq t \leq 4$. Calculate the velocity function $\frac{dx}{dt}$ and the acceleration function $\frac{d^2x}{dt^2}$. Use them to help you give a detailed description of the position of the particle:
 - (a) At what times is the particle (instantaneously) at rest, and where does this happen?
 - (b) During what time intervals is the position x increasing? When is x decreasing?
 - (c) At what times is the acceleration of the particle zero? What does this signify?
 - (d) What is the complete range of positions of the particle?
 - (e) What is the complete range of velocities of the particle?
7. The parametric equation $(x, y) = (5 \cos t, 15 \sin t)$ traces the ellipse $9x^2 + y^2 = 225$ once as t varies from 0 to 2π (in radian mode). Find the t -value that corresponds to $(4, 9)$. Use the components of velocity $\frac{dx}{dt}$ and $\frac{dy}{dt}$ to find the slope $\frac{dy}{dx}$ of the line drawn tangent to the ellipse at $(4, 9)$.
8. Given $f(x) = \cos(\ln x)$ and $g(x) = \ln(\cos x)$, find $f'(x)$ and $g'(x)$. Describe the domain and the range of f and of g .

Mathematics 4C

1. A weight suspended on a spring oscillates up and down, its displacement (in cm) from equilibrium described by $f(t) = 5.8 \cos(12.6t)$, where t is in seconds.
 - (a) What is the frequency of the oscillation? (i.e., how many oscillations per second?)
 - (b) Show that acceleration $f''(t)$ is proportional to displacement $f(t)$, with a negative constant of proportionality. This property characterizes simple harmonic motion.

2. Suppose that $f'(a) = 0$, and that $f'(x)$ changes from positive to negative at $x = a$. What does this tell you about the point $(a, f(a))$ on the graph of $y = f(x)$?

3. Let $f(x) = x^n e^{-x}$, where n is a positive integer. Calculate $f'(x)$, rewrite it so that $x^{n-1} e^{-x}$ is a factor, then show that f has a local maximum at $x = n$.

4. Suppose that $f'(a) = 0$, and that $f'(x)$ changes from negative to positive at $x = a$. What does this tell you about the point $(a, f(a))$ on the graph of $y = f(x)$?

5. Suppose that $f'(a) = 0$, but that $f'(x)$ does *not* change sign at $x = a$. What does this tell you about the point $(a, f(a))$ on the graph of $y = f(x)$? Illustrate with an example.

6. Jamie is at the point $J = (0, a)$ offshore, needing to reach the destination $D = (c, -b)$ on land as quickly as possible. The shore of this lake is the x -axis. Jamie is in a boat whose top speed is p , with a motor bike on board whose top speed is q , to be used once the boat reaches land. Let $L = (x, 0)$ be the landing point. Assume that the trip from L to D is along a straight line, as shown. Let $O = (0, 0)$ and $N = (c, 0)$, the points on shore that are closest to J and D , respectively.

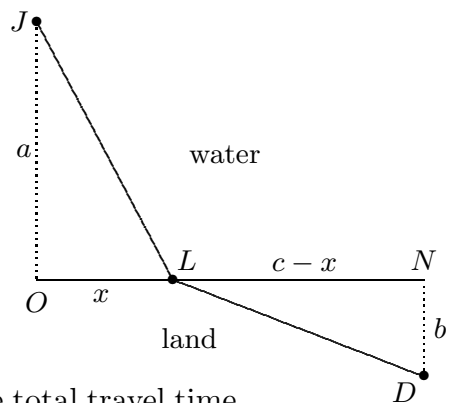

- (a) Find a formula for the total travel time $T(x)$.
- (b) Calculate T' . To find the point L that *minimizes* the total travel time from J to D , it is logical to begin by writing the equation $T'(x) = 0$, but do not attempt to solve this equation for x . Instead, show that $T'(x)$ is equivalent to $\frac{\sin(\angle LJO)}{p} - \frac{\sin(\angle LDN)}{q}$.
When $T'(x) = 0$, it follows that the ratio $\sin(\angle LJO) : \sin(\angle LDN)$ can be written as a simple function of p and q . This result is equivalent to *Snell's Law*, or the *Law of Refraction*.
- (c) By working with $T'(x) = \frac{\sin(\angle LJO)}{p} - \frac{\sin(\angle LDN)}{q}$, show that the x -value that makes $T'(x) = 0$ produces a local *minimum* of $T(x)$. (*Hint*: What happens to $\sin(\angle LJO)$ when x is diminished from its critical value? What happens to $\sin(\angle LDN)$?)

7. Alex the geologist is in the desert, 18 km north of a long, east-west road. Base camp is also in the desert, 18 km north of the road and 72 km east of Alex, whose jeep can do 32 kph in the desert and 60 kph on the road. Alex wants to return to base camp as quickly as possible. In what direction should Alex drive to reach the road, and how many km should be driven on the road? How much time will the trip take?

Mathematics 4C

1. In addition to the circular functions \cos , \sin , and \tan , their reciprocal functions — \sec , \csc , and \cot , respectively — play important roles in calculus. Find first derivatives for these three reciprocal functions.
2. Find the points on the graph of $y = e^{-x^2}$ where the slopes are *extreme*. These points are examples of what mathematicians call *inflection points*.
3. Make up examples $y = f(x)$ for which f is differentiable, $f(3) = 2$, $f'(3) = 0$, and
 - (a) $(3, 2)$ is a relative maximum on the graph;
 - (b) $(3, 2)$ is a relative minimum on the graph;
 - (c) $(3, 2)$ is neither a relative maximum nor a relative minimum on the graph.
4. At an inflection point, the tangent line does something unusual, which tangent lines drawn at non-inflection points do not do. What is this unusual behavior?
5. The parametric equation $(x, y) = (4 \tan t, 3 \sec t)$ traces both branches of the hyperbola $16y^2 - 9x^2 = 144$ as t varies from 0 to 2π (in radian mode). Find the t -value that corresponds to $(\frac{16}{3}, 5)$. Show how the components of velocity $\frac{dx}{dt}$ and $\frac{dy}{dt}$ can be used to find the slope $\frac{dy}{dx}$ of the line drawn tangent to the hyperbola at $(\frac{16}{3}, 5)$.

6. (Continuation) Find $\frac{dy}{dx}$ using a non-parametric approach.

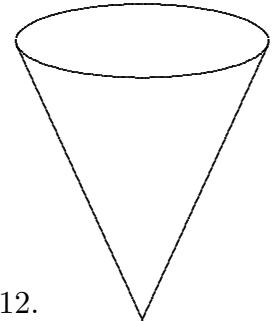

7. A conical reservoir is 12 feet deep and 8 feet in diameter. Water is being pumped into this reservoir at 20 cubic feet per minute.
 - (a) Let V be the volume of the water and y be the depth of the water, both functions of t . Express V in terms of y .
 - (b) Find $\frac{dy}{dt}$ at the instant when $y = 5$ and at the instant when $y = 12$.

8. Not wanting to be caught exceeding the speed limit, the driver of a red sports car suddenly decides to slow down a bit. The table at right shows how the speed of the car (in feet per second) changes second by second. Estimate the distance traveled during this 6-second interval.

<i>time</i>	<i>speed</i>
0	110.0
1	99.8
2	90.9
3	83.2
4	76.4
5	70.4
6	65.1

9. (Continuation) The red sports car's speed during the time interval $0 \leq t \leq 6$ is actually described by the function $f(t) = \frac{44000}{(t + 20)^2}$. Use this function to calculate the exact distance traveled by the sports car.

10. Find *antiderivatives* for the following:

(a) $\frac{1}{y} \frac{dy}{dt}$ (b) $\sqrt{y(t)} y'(t)$ (c) $f'(t) \sin f(t)$ (d) $\frac{1}{1+w^2} \frac{dw}{dt}$ (e) $e^u u'$

Express each answer in terms of the indicated unknown function — y , f , w , or u .

Mathematics 4C

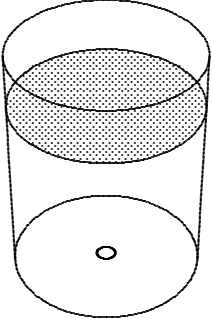
1. Evaluate $\lim_{x \rightarrow \infty} \arctan' x$. Does this number provide any information about the graph of $y = \arctan x$?
2. What can be said about the derivative of **(a)** an odd function? **(b)** an even function?
3. Consider the function f defined for all x by the rule $f(x) = \begin{cases} x^{1/3} & \text{for } -1 \leq x \leq 1 \\ 1 & \text{for } 1 < |x| \end{cases}$. Notice that f is nondifferentiable at three points, and that f has one point of discontinuity. Express these facts using limit notation.
4. An object moves along the curve $y = \sin x$ so that $\frac{dx}{dt}$ is constantly 4. Find $\frac{dy}{dt}$ at the instant when **(a)** $x = 0$; **(b)** $x = \frac{1}{2}\pi$; **(c)** $x = \frac{3}{4}\pi$; **(d)** $x = \pi$.
5. If you apply $\frac{d}{dt}$ to both sides of $2\sqrt{y} = 8 - 0.4t$, thinking of y as a function of t , you will obtain the differential equation $\frac{1}{\sqrt{y}} \frac{dy}{dt} = -0.4$. One of its solutions is $2\sqrt{y} = 8 - 0.4t$, of course, but there are many others, including one that satisfies the condition $y(0) = 49$. Find this solution, and rewrite it to show that y is a quadratic function of t .
6. The water in a cylindrical tank is draining through a small hole in the bottom of the tank. The depth of water in the tank is governed by *Torricelli's Law*: $\frac{dy}{dt} = -0.4\sqrt{y}$, where y is measured in cm and t is measured in seconds. (The rate constant 0.4 depends on the size of the cylinder and the size of the hole.) For example, if the water were 49 cm deep, the water level would be dropping at 2.8 cm per second at that instant. Suppose that the water were 36 cm deep; estimate the depth of the water half a second later.
 
7. (Continuation) By writing Torricelli's Law in the form $\frac{1}{\sqrt{y}} \frac{dy}{dt} = -0.4$, calculate the depth of the water as a function of t . You will need to use the information $y(0) = 36$ to choose the correct antiderivative.
 - (a)** Compare $y(0.5)$ with your estimate in the preceding question. Was your estimate too high or too low? Could you have predicted this?
 - (b)** Calculate how many seconds will be needed to empty the tank completely.
8. Suppose that $f''(a) = 0$, and that $f''(x)$ changes from negative to positive at $x = a$. What does this tell you about the point $(a, f(a))$ on the graph of $y = f(x)$?
9. Many mathematicians define an inflection point on a graph $y = f(x)$ to be a point at which $f''(x)$ changes sign. Find coordinates for the inflection points on the graph $y = xe^{-x}$, and justify your choices.

Mathematics 4C

1. Suppose that $f''(a) = 0$, and that $f''(x)$ changes from positive to negative at $x = a$. What does this tell you about the point $(a, f(a))$ on the graph of $y = f(x)$?
2. After reading that $f''(a) = 0$ and that $f''(x)$ does *not* change sign at $x = a$, Val concluded that the point $(a, f(a))$ must be an extreme point on the graph of $y = f(x)$. Remy disagreed with Val, by offering the example $f(x) = 2x$. Explain, then find a nonlinear example that Remy could also have used to change Val's opinion.
3. Apply the technique of implicit differentiation to find $D_x y$ for the curve $x = \tan y$.
4. (Continuation) Find a formula for the derivative of $y = \arctan x$ in terms of x .
5. The graph $y = x^n e^{-x}$ has two inflection points when $n = 2$. Find their x -coordinates and justify your classification.
6. (Continuation) The graph $y = x^n e^{-x}$ has three inflection points when $n = 3$. Find x -coordinates for all of them, and justify your classification.
7. Find $\lim_{x \rightarrow 1^-} \arcsin' x$. What does this result tell you about the graph of $y = \arcsin x$? The notation $x \rightarrow 1^-$ reminds you that x is approaching 1 from the left — through values that are less than 1. Why is this restriction on x necessary?

8. A container is being filled with water. The table shows that the area of the water surface increases as the water gets deeper. Depths are measured in inches and areas in square inches. Use this data to estimate the total number of cubic inches of water in the container when the water is 6 inches deep.

<i>depth</i>	<i>area</i>
0	12.6
1	19.6
2	28.3
3	38.5
4	50.3
5	63.6
6	78.5

9. (Continuation) It so happens that the the surface area of the water is $A(y) = \pi(2 + 0.5y)^2$ when the water is y inches deep. First verify that this function was used to calculate the table entries. There are now at least two ways to use $A(y)$ to calculate a more accurate answer to the preceding volume question. Find the most accurate value that you can for the volume.

10. The differential equation $\frac{dy}{dt} = -\frac{1}{3}y^2$ is given.
 - (a) Confirm that $y(t) = \frac{3}{t}$ is a solution, but
 - (b) that neither $y(t) = \frac{3}{t} + 2$ nor $y(t) = \frac{2}{t}$ is a solution.
 - (c) Find another solution to the differential equation.

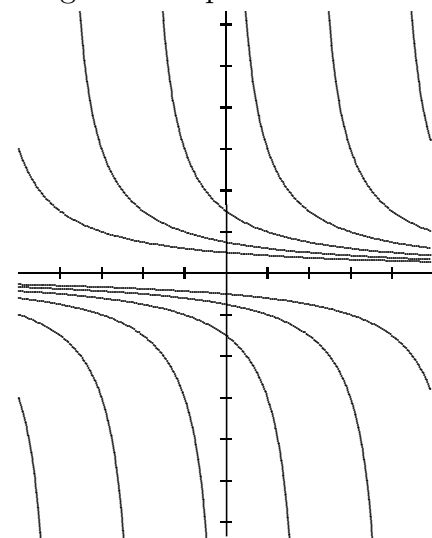

11. Calculate $\frac{dy}{dx}$ for the graph of $y = \ln|x|$.
12. Find the extreme points on $y = x + \frac{c}{x}$, where c is a positive constant. Justify your choices.

Mathematics 4C

1. With an unobstructed view of the entire race, you are videotaping the 100-meter dash at the Exeter-Andover track meet, stationed at a point 12 meters inside the track, at the 50-meter mark. Your camera is following a runner who is moving at 10.5 meters per second. At what rate (in radians per second) is your camera rotating **(a)** when the runner is closest to you? **(b)** one second after that?

2. Some second-order chemical reactions are modeled by the equation $\frac{dp}{dt} = -k \cdot p^2$, where k is a positive rate constant. Suppose that $k = 0.18$ and $p(0) = 0.76$. Find $p(t)$. What is $\lim_{t \rightarrow \infty} p(t)$?

3. The figure shows the graph of a differentiable function g . The curve goes through the origin. Mark the point on the curve where the ratio $\frac{g(x)}{x}$ reaches its largest value.

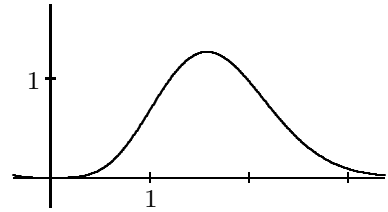

4. Show that the Product Rule applies to $g(x) = c \cdot f(x)$, the Quotient Rule applies to $g(x) = \frac{f(x)}{c}$, and that neither rule is needed if c is a constant.

5. As t varies, the equation $y = 3x + t$ produces parallel lines with varying y -intercepts. The graph can be thought of as a moving line, whose y -intercept increases at 1 unit per second. At what rate does the x -intercept change?

6. (Continuation) Modify the equation so that it represents a moving line of slope 3 whose y -intercept is *decreasing* at 4 units per second. At what rate does the x -intercept change?

7. (Continuation) The graph of $y = x^2 - t$ can be thought of as a moving parabola, whose y -intercept decreases at 1 unit per second. When t is positive, the parabola also has x -intercepts. As the y -intercept decreases, the distance between the x -intercepts increases, although not at a constant rate. Calculate an expression for this rate of separation.

Mathematics 4C

1. The diagram shows a light ray entering a spherical raindrop and leaving it after undergoing one internal reflection. The change of direction at the air-water interface is governed by *Snell's Law of Refraction* $\sin \beta = k \sin \theta$, where k is a positive constant. In this example, use $k = 0.75$. Angles θ and β are measured with respect to surface normals (lines that are perpendicular to the air-water interface). The latitude of the incoming ray is θ , and the angle of depression of the outgoing ray is ψ (the dashed line in the diagram is parallel to the incoming ray).

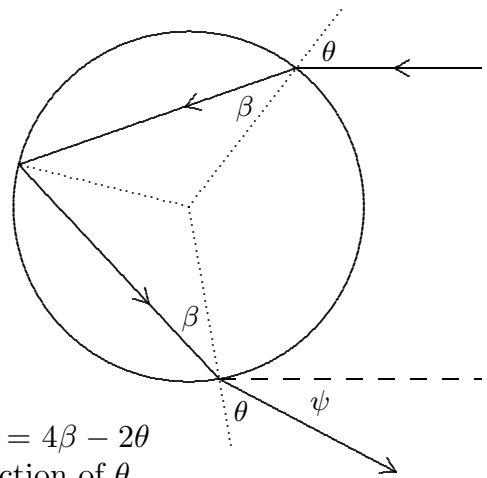

(a) Show that $\beta = 0.5681$ when $\theta = 0.8$ (radians).

(b) Show that $\psi = 0.6723$ when $\theta = 0.8$, and that $\psi = 4\beta - 2\theta$ in general. Now use Snell's Law to express ψ as a function of θ .

(c) As θ increases from 0 to $\frac{1}{2}\pi$, angle ψ increases from 0 to a maximum value and then decreases. Calculate $D_{\theta}\psi$, and use it to find the maximum value of ψ . This angle determines where a *rainbow* appears in the sky after a late-afternoon thunderstorm.

2. (Continuation) The maximum value of the rainbow angle ψ depends on the refractive index k , of course. In turn, k actually depends on the *color* of the incident light. For example, the index $k = 0.75$ belongs to yellow light. The indices that belong to the extreme colors of the visible spectrum are $k = 0.7513$ for red and $k = 0.7435$ for violet. For each, find the corresponding extreme value of ψ . Then show that the apparent width of a rainbow is about 2 degrees (about four times the apparent diameter of the Moon).

3. As t increases from 0 to π , the number $\sin t$ increases from 0 to 1 then decreases back to 0. Given a random t -value between 0 and π , the sine of that t -value is thus a number between 0 and 1. If you were to calculate sine values in this way for thousands of random t -values, however, you would find that (a) 66.7% of the sine values would be between 0.5 and 1.0; that (b) 28.7% of the sine values would be between 0.9 and 1.0; and that (c) 9.0% of the sine values would be between 0.99 and 1.00. Explain this *concentration* of sine values near 1.0.

4. If a function is discontinuous at a point, then it is necessarily nondifferentiable at that point also. Explain why, and give an example.

5. Find the constant k for which the parabola $y = kx(\pi - x)$ and the curve $y = \sin x$ have matching slopes at their two common x -intercepts.

6. You have solved some *separable* differential equations — antiderivative problems that can be written in the form $f(y)\frac{dy}{dx} = g(x)$. Show that $\frac{dy}{dx} = 2xy^2$ is also of this type, by writing the equation in this form. Then find the solution curve that goes through $(5, 1)$.

7. The derivative of a step function has only one value, and yet it could be misleading to simply say that the derivative is a “constant function.” Why?

Mathematics 4C

1. The speed of a red sports car is given by the function $f(t) = \frac{44000}{(t+20)^2}$ for $0 \leq t \leq 6$.
- (a) Explain why the sums $\sum_{k=0}^5 1 \cdot f(k)$ and $\sum_{k=1}^6 1 \cdot f(k)$ are reasonable approximations to the distance traveled by the sports car during this 6-second interval, and why the true distance is between these two estimates.
- (b) It is frequently suggested that the *average* of the preceding sums approximates the actual distance better than either sum does. What do you think?
- (c) Explain why $\sum_{k=0}^{11} 0.5f(0.5k)$ is a better approximation than $\sum_{k=0}^5 1 \cdot f(k)$ is.
- (d) Explain why $\sum_{k=0}^{119} 0.05f(0.05k)$ is an even better approximation.
2. Comment on the vague statements “the graph is increasing” and “the slope is increasing.” Do they have the same meaning?
3. Invent a function f , defining $f(x)$ for all x in such a way that f is
- (a) discontinuous for exactly one value of x ;
- (b) discontinuous for exactly two values of x ;
- (c) continuous for all values of x and nondifferentiable for exactly two values of x .
4. Alex is in the desert in a jeep, 10 km from a long, straight road. On the road, the jeep can do 50 kph, but in the desert sands, it can manage only 30 kph. Alex is very thirsty, and knows there is a gas station (with ice-cold Coke) 6 km up the road (from the nearest point on the road). What is the shortest time for Alex to get a Coke?
5. Let $P = (a, \cos a)$ be a point on the cosine graph, where a is nonzero and $|a| < \pi$.
- (a) The line through P that is perpendicular to the tangent line at P is called a *normal line*. Find an equation for it.
- (b) This line intersects the y -axis — itself a normal line for the cosine curve — at $(0, y_a)$. Write a formula for y_a ; your answer should depend on a , of course.
- (c) What is the limiting value of y_a as a approaches zero?
- (d) Asked for a quantitative description of the *curvature* of the cosine graph near the y -axis, a student said, “it is curved like a circle of radius 1.” Explain this remark.
6. What is the area enclosed by the x -axis and the graph $y = \sin x$ for $0 \leq x \leq \pi$?
7. Consider the function $f(x) = x^{5/3} - 5x^{2/3}$, which is defined and continuous for all x .
- (a) Write $x^{5/3} - 5x^{2/3}$ in factored form, using $x^{2/3}$ as one factor.
- (b) Explain why $f(x)$ is positive only for $x > 5$. Conclude that $(0, 0)$ is a local maximum point on the graph of $y = f(x)$.
- (c) Calculate $f'(x)$, show that $x^{-1/3}$ is a factor, and use the factorization to find all the x -values for which $f'(x) < 0$.
- (d) Is f a differentiable function?
- (e) Use the previous results to sketch a graph of $y = f(x)$.

Mathematics 4C

1. There is no general method that will find explicit solutions to every differential equation, but the antidifferentiation approach can be applied to separable equations. For example, you have seen how $\frac{dy}{dt} = -0.4\sqrt{y}$ can be solved by rewriting it $\frac{1}{\sqrt{y}} \frac{dy}{dt} = -0.4$, then antidifferentiating both sides to obtain $2\sqrt{y} = -0.4t + c$. Notice that there are infinitely many solutions, thanks to the *antidifferentiation constant* c . Another separable example that occurs often is illustrated by $\frac{dy}{dt} = -0.4y$, which can be rewritten as $\frac{1}{y} \frac{dy}{dt} = -0.4$. Now apply antidifferentiation to both sides to obtain $\ln y = -0.4t + c$, which is equivalent to $y = ke^{-0.4t}$.

- (a) Show that $\frac{dy}{dt} = y^2 \sin t$ can be solved by the separable approach.
- (b) Show that $\frac{dy}{dt} = y + 2$ can be solved by the separable approach.
- (c) Show that $\frac{dy}{dt} = y + 2t$ is not a separable equation.

2. (Continuation) Is it necessary to place an antidifferentiation constant on *both* sides of an antidifferentiated equation? Explain.

3. Two soap bubbles joined by a pipe contain 6 liters of air. The volume of the bubble on the left is V , and the volume of the bubble on the right is $6 - V$. Show that the surface area of the

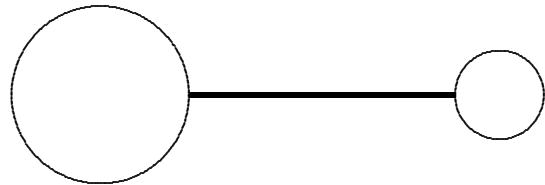

left bubble is $4\pi\left(\frac{3V}{4\pi}\right)^{2/3} = (36\pi)^{1/3}V^{2/3}$, and that $S = (36\pi)^{1/3}\left(V^{2/3} + (6 - V)^{2/3}\right)$ is the total surface area of the two bubbles. Find the extreme values of S , and the volumes V that produce them. Given that the surface area of a soap film is always as small as it can be for the volume enclosed, discuss the stability of the configuration in the diagram.

4. The second derivative of $f(x) = x^4$ is 0 when $x = 0$. Does that mean that the origin is an inflection point on the graph of f ? Explain.

5. Trying to give a quantitative description of the curvature of the parabola $y = 1 - x^2$ near the y -axis, a student said that “the parabola is curved like a circle of radius $\frac{1}{2}$.” Explain this remark.

6. The speed of a red sports car is described by $f(t) = \frac{44000}{(t + 20)^2}$ for $0 \leq t \leq 6$.

(a) Given a large positive integer n , the sum $\sum_{k=1}^n \frac{6}{n} f\left(\frac{6k}{n}\right)$ is a reasonable estimate of the distance traveled by the sports car during this 6-second interval. Explain why.

(b) Another reasonable estimate is $\sum_{k=0}^{n-1} \frac{6}{n} f\left(\frac{6k}{n}\right)$. Compare it to the preceding.

(c) Explain the significance of the expression $\lim_{n \rightarrow \infty} \sum_{k=1}^n \frac{6}{n} f\left(\frac{6k}{n}\right)$. You have already found the value of this expression in an earlier exercise; what is it?

Mathematics 4C

1. Let $x(t)$ be the position of an object moving along a number line. Suppose that the velocity of the object is $\frac{dx}{dt} = 4 - 3 \cos 0.5t$ for all t . Calculate and compare
- the displacement of the object during the interval $0 \leq t \leq 2\pi$;
 - the distance traveled by the object during the interval $0 \leq t \leq 2\pi$.

2. You have encountered at least four notations — f' , $\frac{df}{dx}$, Df , and $D_x f$ — for the derivative of a function f . You may have noticed a lack of notation for *antiderivatives*, however. This situation will be taken care of soon. Until then, you will have to invent your own notation! In the process, you might notice why devising a notation for antiderivatives is a more complicated task than devising a notation for derivatives. Why?

3. Cameron, a student of Calculus, was instructed to find the derivative — with respect to x — of five functions, each expressed in terms of an unknown function y . Below are Cameron's five answers. For each, reconstruct the expression that Cameron differentiated. You will have to write your answers in terms of y (and x), of course. Can you be absolutely sure that your answers agree with the questions on Cameron's assignment?

(a) $2.54 + \frac{dy}{dx}$ (b) $\frac{dy}{dx} \sec^2 y$ (c) $\sqrt{5y} \frac{dy}{dx}$ (d) $\frac{7}{y^2} \frac{dy}{dx}$ (e) $(y - \cos x) \left(\frac{dy}{dx} + \sin x \right)$

4. The *cycloid* below is traced by the parametric equation $(x, y) = (t - \sin t, 1 - \cos t)$. Estimate the area enclosed by the x -axis and one arch of this curve.

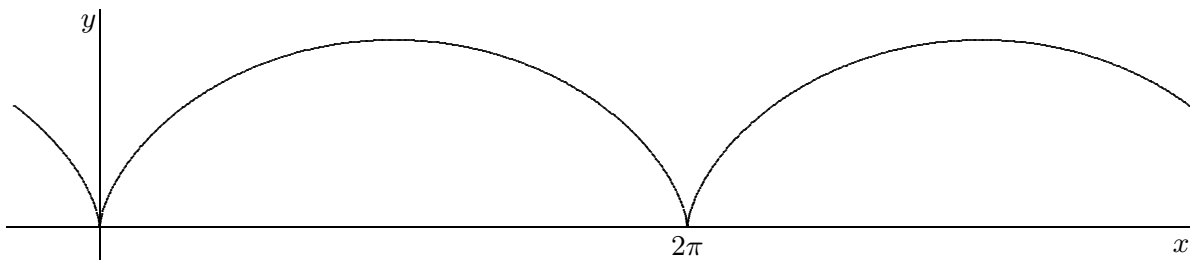

5. The density of air that is x km above sea level is $f(x) = 1.225(0.903)^x$ kg per cubic meter. Approximate the number of kg of air in a column that is one meter square, five *kilometers* tall, and based at sea level, by breaking the column into blocks that are one km tall. Make another approximation by breaking the column into blocks that are only one meter tall. (Recall that your calculator can be used to sum a series.) Which answer is a better approximation? By the way, you are calculating the *mass* of the column of air. To test the plausibility of your answer, re-calculate the mass assuming that its density is constant, using both the sea-level value and the 5-km value.

6. (Continuation) It is possible to find an exact answer for the air mass, without summing a geometric series. Calculate this exact value, assuming that base of the five-km tall column of air is (a) at sea level; (b) five kilometers above sea level.

7. Having recently learned about logarithms and derivatives, Kelly thinks that $\ln(x^4)$ is an antiderivative for $\frac{1}{x^4}$. Give Kelly some helpful advice.

Mathematics 4C

1. Integral notation. You have now worked through a few accumulation problems, such as: finding the *distance* traveled by a sports car; finding the *volume* of water in a container; finding the *area* of a sinusoidal region; finding the *area* of a cycloidal region; and finding the *mass* of a column of air. In each case, the desired quantity could be approximated to any degree of accuracy by a *sum of products* — rate times time, area times height, etc. The precise answer was thus a *limit* of such sums. For example, if the cross-sectional area of a solid is $A(x)$ for $0 \leq x \leq b$, and $\Delta x = b/n$, then the volume of the solid is

$$\int_0^b A(x) dx = \lim_{n \rightarrow \infty} \sum_{k=1}^n A(k\Delta x) \Delta x.$$

The expression $\int_0^b A(x) dx$ for the precise volume is read “the *integral* of $A(x)$ from $x = 0$ to $x = b$.” The integration symbol is an elongated S — the initial letter of *sum*. The symbol dx , although it does not stand for a specific value, corresponds to the Δx that appears in the approximating sum, and it identifies the *integration variable*.

(a) Write the integral for the distance traveled by a car whose speed is $f(t)$ for $0 \leq t \leq 6$.

(b) For this car, write the integral that corresponds to the time interval $3 \leq t \leq 5$.

(c) Write an equivalent integral for: (i) $\lim_{n \rightarrow \infty} \sum_{k=1}^n \sin\left(\frac{k\pi}{n}\right) \cdot \frac{\pi}{n}$ (ii) $\lim_{n \rightarrow \infty} \sum_{k=1}^n \left(\frac{2k}{n}\right)^2 \cdot \frac{2}{n}$

2. The Fundamental Theorem of Calculus. On most of the accumulation problems, you have managed to avoid both the work of summing many terms, and the need to consider a complicated limit problem, by realizing that an *antiderivative* for f can be used to solve the problem. In its general form, the Theorem says: If $F'(x) = f(x)$, then the value of $\int_a^b f(x) dx$ is $F(b) - F(a)$. A written application of this result typically takes the form

$$\int_a^b f(x) dx = F(x) \Big|_a^b = F(b) - F(a).$$

(a) Apply the Fundamental Theorem (use an antiderivative) to find the area of the first-quadrant region that is enclosed by the coordinate axes and the parabola $y = 9 - x^2$.

(b) Evaluate and interpret the two integrals you wrote in part (c) of the preceding problem.

3. Write an approximating sum (called a *Riemann sum*) for $\int_0^3 (9 - x^2) dx$.

4. The graph of $y^2 - xy = 4 + 2x^2$ is a hyperbola. Use the technique of implicit differentiation to find the slope of the tangent line at the point $(1, 3)$.

5. At the origin, the parabola $y = kx^2$ is curved like a circle of radius $\frac{1}{2|k|}$. Confirm this.

6. Find the solution to $\frac{dy}{dx} = -\left(\frac{y}{x}\right)^{1/3}$ that goes through the point $(8, 1)$.

7. The *sign function* is defined by $\text{sgn}(x) = \frac{x}{|x|}$ for all nonzero values of x . Draw its graph, calculate its derivative, and comment on its continuity and differentiability.

Mathematics 4C

1. Given the equation $y = x\sqrt{x}$, a new calculus student used the Product Rule to show that $\frac{dy}{dx} = 1 \cdot \sqrt{x} + x \cdot \frac{1}{2\sqrt{x}}$. Simplify this answer. Find a better way of calculating $\frac{dy}{dx}$.

2. The acceleration of an object falling near the surface of the Earth is essentially constant. In fact, the height y of the object satisfies the differential equation $\frac{d^2y}{dt^2} = -32$, where position is measured in feet and time is measured in seconds. Suppose that an object is dropped (not thrown) at time $t = 0$ from an initial height of 784 feet. Calculate the height of the object as a function of t , and the speed of the object as it strikes the ground.

3. The graph of the equation $y^2 + 2x^2 = x^3 + x$ is shown at right. Calculate $\frac{dy}{dx}$ implicitly, then find coordinates for the points on the graph where the value of y is locally extreme.

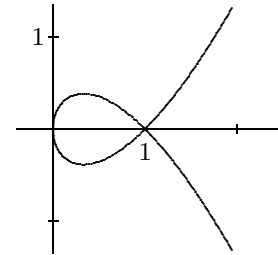

4. Explain why $\sum_{k=1}^n \frac{1}{1 + (2k/n)} \cdot \frac{2}{n} < \int_0^2 \frac{1}{1+x} dx < \sum_{k=0}^{n-1} \frac{1}{1 + (2k/n)} \cdot \frac{2}{n}$ holds for any positive integer n . By the way, the Riemann sum on the left is sometimes called a *right-hand* sum. With the help of a diagram, explain the terminology.

5. Water is poured into a hemispherical bowl whose radius is 10 inches. Use your integration expertise to show that the bowl is $5/16$ full when the water is 5 inches deep. You could start your solution by showing that the surface area of the water is $\pi(20y - y^2)$ when the depth of the water is y .

6. Given that $f(x)$ is defined continuously for $a \leq x \leq b$, an x -value is called *critical* for the function f if $f'(x) = 0$ or if $f'(x)$ is undefined. The reason why such values are interesting is the following theorem (which will be accepted without proof):

If $f(x)$ is continuous for $a \leq x \leq b$, then the global maximum of $f(x)$ and the global minimum of $f(x)$ occur at critical x -values, or at the endpoints $x = a$ or $x = b$.

Invent functions f (simple sketches suffice if you cannot think of formulas) that illustrate these situations:

(a) The global maximum of $f(x)$ occurs at $x = a$, and the global minimum occurs strictly between a and b , at a point of nondifferentiability.

(b) The global extremes of $f(x)$ occur strictly between a and b , one at a point of nondifferentiability, the other where $f'(x) = 0$.

7. Asked to find $\frac{dy}{dx}$ for the curve $y = 2^x$, Val wrote $\frac{dy}{dx} = x \cdot 2^{x-1}$. Do you agree?

8. Verify that the curve $y^2 + 2x^2 = x^3 + x$ is traced parametrically by $x = t^2$ and $y = t^3 - t$. Use these two equations to find the slope of the line that is tangent to the curve at $(4, 6)$. Find coordinates for the two points on the curve where the y -coordinate is locally extreme.

Mathematics 4C

1. Which point on the parabolic arc $y = \frac{1}{2}x^2$ for $0 \leq x \leq 3$ is closest to $(0, 2)$?
2. A pyramid that is 12 inches tall has a 10-inch by 10-inch square base. The pyramid is sliced by a plane that is y inches from the vertex and parallel to the base; let $A(y)$ be the area of the square cross-section. Find a formula for $A(y)$. Your formula should tell you that $A(12) = 100$. Evaluate $\int_0^{12} A(y) dy$ and explain the significance of the answer.
3. Shown at right is the graph of an increasing function f . Notice that $f(2) = 3$.
 - (a) Sketch the graph of $y = f^{-1}(x)$.
 - (b) Use the graphs to estimate the values of the derivatives $Df(2)$ and $Df^{-1}(3)$.
4. At noon, a blue sports car was 15 miles south of an intersection, heading due north along a straight highway at 40 mph. Also at noon, a red sports car was 20 miles west of the same intersection, heading due east along a straight highway at 80 mph.
 - (a) The cars were 25 miles apart at noon. At what rate was this separation decreasing?
 - (b) At 1 pm, the cars were 65 miles apart. At what rate was this separation increasing?
 - (c) At what time of day were the cars closest together, and how far apart were they?
5. The graph $y = ax^3 + bx^2 + cx + d$ of a cubic polynomial has an inflection point at $(0, 3)$ and a local maximum at $(1, 5)$. Find the values of a , b , c , and d .
6. A plastic box has a square base, rectangular sides, but no top. The volume of the box is 256 cubic inches. What is the smallest possible combined five-face surface area for such a box, and what are the corresponding box dimensions? Justify your answer.
7. The useful definition $f(t) = (1 + r)^t$ can be rewritten $f(t) = e^{\alpha t}$ for some number α .
 - (a) Letting $r = 0.05$, calculate α .
 - (b) Using this value of α , sketch the graphs of $y = e^{\alpha t}$ and $y = 1 + \alpha t$ on the same system of coordinate axes. How are these graphs related?
 - (c) Although the linear model is attractively simple to work with, the exponential model slowly diverges from it. What is the smallest positive value of t for which the linear y -value is at most 99% of the exponential y -value?
 - (d) Replace t by $d/365$ and interpret the results of this investigation.
8. Find a function whose graph $y = f(x)$
 - (a) has negative slopes, which increase as x increases;
 - (b) has positive slopes, which decrease as x increases.
9. If $0 < f''(a)$, then the graph of $y = f(x)$ is said to be *concave up* (or have *positive curvature*) at the point $(a, f(a))$. Explain this terminology. If $f''(a) < 0$, then the graph of $y = f(x)$ is said to be *concave down* (or have *negative curvature*) at the point $(a, f(a))$. Explain this terminology, too.

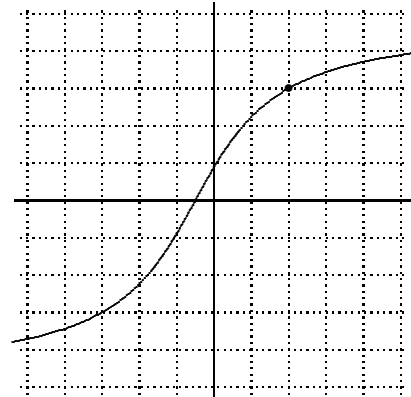

Mathematics 4C

1. Show that $f(t) = t - \sin t$ is increasing and differentiable. Although there is no explicit formula for the inverse function f^{-1} , it is possible to find both $Df^{-1}(\pi)$ and $Df^{-1}(\frac{1}{2}\pi - 1)$, and to show that f^{-1} has points of nondifferentiability. Do so. Make a diagram.

2. The population of the Earth was 4.32 billion persons in 1978 and 5.76 billion persons in 1994. Show that the differential equation $P' = kP$ leads to the usual exponential model for unconstrained population growth. Use this model to calculate when the population of the Earth will reach 10 billion. (This prediction will soon be revised by using a *logistic model* $f' = m \cdot f \cdot (1 - f)$ for constrained growth, in which the population $P(t)$ is expressed as a fractional part $f(t)$ of some maximal sustainable size.)

3. Although a logistic differential equation such as $f' = 0.8f \cdot (1 - f)$ is separable, it is not yet easy to antidifferentiate. There is a unique solution that satisfies the initial condition $f(0) = 0.36$, however. To find $f(1.0)$ for this solution, you can proceed numerically: The prescribed value $f'(0) = 0.18432$ allows you to calculate an approximate value for $f(0.1)$. The value for $f'(0.1)$ is also prescribed, which allows you to calculate an approximate value for $f(0.2)$, and so on. This is *Euler's method* of numerically solving a differential equation. Compare your approximation for $f(1.0)$ with the actual value, which is 0.55592...

4. A one-meter length of wire is to be used to enclose area, in one of three ways: bend it to form a circle, bend it to form a square, or cut it and bend the pieces to form a circle *and* a square. Describe in detail the procedure that will yield a total enclosed area that is **(a)** largest; **(b)** smallest.

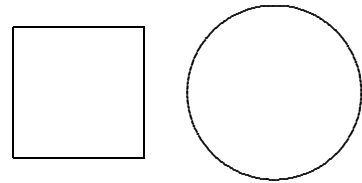

5. It is often the case that a set of parametric equations is written using a parameter that actually means something. For example, reconsider the curve $y^2 + 2x^2 = x^3 + x$, which goes through the point $(1, 0)$. The equation $y = t \cdot (x - 1)$ describes a line of slope t that also goes through this point. Use algebra to find the *other* point where this line intersects the curve, and show that its coordinates are $(t^2, t^3 - t)$. You need to notice that $x^3 - 2x^2 + x$ can be factored.

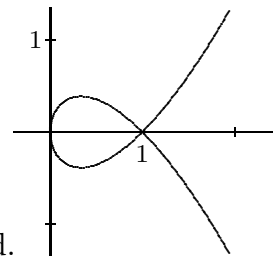

6. (Continuation) The curve goes through the point $(1, 0)$ twice, with two different slopes. Use the parametric equations $x = t^2$ and $y = t^3 - t$ to help you find these two slopes.

7. Interpret the equation $Df^{-1}(x) = \frac{1}{Df(f^{-1}(x))}$, then derive it. One way to proceed is to start with $x = f(f^{-1}(x))$ and apply D to both sides of the equation. (Remember the Chain Rule.)

8. Verify that $\frac{2}{x \cdot (x - 2)}$ is equivalent to $\frac{1}{x - 2} - \frac{1}{x}$. (Notice the common denominator.)

9. (Continuation) You should now be able to evaluate the integral $\int_3^5 \frac{2}{x(x - 2)} dx$, without the use of a calculator. Show that your answer can be expressed as $\ln(9/5)$.

Mathematics 4C

1. Euler's method for solving differential equations is a recursive process. For example, reconsider the logistic example $f' = 0.8f \cdot (1 - f)$, with initial condition $f(0) = 0.36$, step size 0.1, and target value $f(1.0)$. If you let $u_0 = 0.36$, and apply the recursive formula $u_n = u_{n-1} + 0.8u_{n-1}(1 - u_{n-1})(0.1)$ ten times, you will obtain u_{10} , which is a good approximation to the value $f(1.0)$. Modify this recursion to deliver greater accuracy.
2. The standard method of approximating an integral $\int_a^b f(x) dx$ is to use a *Riemann sum*. The interval of integration $a \leq x \leq b$ is divided into subintervals I_1, I_2, I_3, \dots , and I_n , whose lengths are w_1, w_2, w_3, \dots , and w_n , respectively. (The lengths are often all the same, but they need not be.) For each subinterval I_k , a single value $f(x_k)$ is calculated using a value x_k from I_k . The Riemann sum is then $f(x_1)w_1 + f(x_2)w_2 + f(x_3)w_3 + \dots + f(x_n)w_n$. There are different schemes for choosing the evaluation points x_k , and the corresponding sums are named accordingly. What are the schemes that correspond to *left-hand sum*, *right-hand sum*, *lower sum*, *upper sum*, and *midpoint sum*?
3. The *trapezoidal sum* is obtained as the arithmetic mean of the left-hand sum and the right-hand sum. Explain the name, then show that this scheme actually fits the definition of a Riemann sum when f is a continuous function.
4. Sketch a decreasing, continuous, nonlinear $y = f(x)$ for some interval $a \leq x \leq b$. Divide the interval into ten subintervals, not necessarily all the same width. Based on each subinterval, draw a rectangle whose height is $f(x)$, for some x in the subinterval. Use this diagram to show that the difference between your Riemann sum and the exact value of its integral is at worst $(f(a) - f(b))w$, where w is the width of the widest subinterval.
5. A conical tank (point down) is being filled with water at a steady rate, k cubic feet per minute. The container is 4 feet deep and 2 feet in diameter. When the water is 3 feet deep, the water level is rising at 1 inch per minute. What is k ?
6. An object moves along the x -axis, its velocity at time t seconds described by the formula $\frac{dx}{dt} = 4 - 5 \sin t$. The object is at position $x = 3$ when $t = 0$.
 - (a) What is the position of the object when $t = \pi$? when $t = 2\pi$?
 - (b) Find a one-second interval during which the object is moving in the negative x -direction. During this interval, find the greatest speed of the object.
 - (c) How far does the object travel during the 2π -second interval $0 \leq t \leq 2\pi$?
7. Sketch the ellipse $(x, y) = (2 \cos t, \sin t)$ for $0 \leq t \leq 2\pi$ (in radian mode, of course).
 - (a) Use the derivatives dx/dt and dy/dt to write a formula — in terms of t — for the slope dy/dx at any point of the ellipse.
 - (b) Given a point $P = (2 \cos a, \sin a)$ on the ellipse that is close to the intercept $(0, 1)$, let b be the y -intercept of the line that intersects the ellipse perpendicularly at P . What is the limiting value of b as P approaches $(0, 1)$?
 - (c) Of all the circles that touch the ellipse at $(0, 1)$, which one do you think best approximates the ellipse there?
 - (d) Find the *radius of curvature* of this ellipse at its vertex $(2, 0)$.

Mathematics 4C

1. Consider the region that is enclosed by the x -axis, the line $x = t$, and the unit semicircle $y = \sqrt{1 - x^2}$ for $-1 \leq x \leq t$. Use your knowledge of geometry and trigonometry to show that the area of this region is $A(t) = \frac{1}{4}\pi + \frac{1}{2}t\sqrt{1 - t^2} + \frac{1}{2}\arcsin t$.

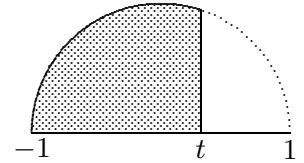

2. (Continuation) Estimate $\Delta A = A(0.61) - A(0.60)$, then calculate ΔA exactly using the formula. Was your estimate too small or too large, and could you have predicted which?

3. (Continuation) Calculate $A'(t)$. Simplify your answer until it fits in here:

4. Verify the identity $\frac{1}{f \cdot (1 - f)} = \frac{1}{f} + \frac{1}{1 - f}$. Use this result to help you solve the logistic differential equation $f' = 0.8f \cdot (1 - f)$, which you should recognize as separable.

(a) Show that the solution can be written in the form $\frac{f}{1 - f} = Ae^{0.8t}$.

(b) Given the *initial condition* $f(0) = 0.36$, express $f(t)$ as an explicit function of t . Evaluate the limiting value of $f(t)$ as t approaches infinity.

5. Apply the trapezoidal method with $\Delta x = 0.25$ to approximate $\int_1^2 \frac{1}{x} dx$. Your answer will be slightly larger than $\ln 2$. How could this have been anticipated?

6. The n -trapezoid approximation to $\int_a^b f(x) dx$, using $\Delta x = \frac{b - a}{n}$ and $n + 1$ evenly spaced functional values $y_0 = f(a)$, $y_1 = f(a + \Delta x)$, \dots , and $y_n = f(b)$, is defined to be

$$\frac{y_0 + y_1}{2} \cdot \frac{b - a}{n} + \frac{y_1 + y_2}{2} \cdot \frac{b - a}{n} + \frac{y_2 + y_3}{2} \cdot \frac{b - a}{n} + \dots + \frac{y_{n-1} + y_n}{2} \cdot \frac{b - a}{n}.$$

This can be rewritten in the illuminating and more efficient form

$$\frac{y_0 + 2y_1 + 2y_2 + \dots + 2y_{n-1} + y_n}{2n} (b - a).$$

Confirm that the two formulas are equivalent, then find a meaning for the fraction that appears in the second formula.

7. The acceleration due to gravity g is not constant — it is a function of the distance r from the center of the Earth, whose radius is R and whose mass is M . You learn in physics that

$$g = \begin{cases} GMrR^{-3} & \text{for } 0 \leq r < R \\ GMr^{-2} & \text{for } R \leq r \end{cases}$$

where G is the gravitational constant. Sketch the graph of g as a function of r . Is g a continuous function of r ? Is g a differentiable function of r ? Without knowing values for G , M , or R , what can you say about the appearance of the graph of g at $r = R$?

8. The liquid in a cylindrical container, whose base area is 4 square ft, is h ft deep. Liquid is entering the tank at 0.08 cu ft/sec, but is escaping at $0.12h$ cu ft/sec. How much time elapses while h increases from 0.1 foot to 0.5 foot?

Mathematics 4C

1. The *Fundamental Theorem of Calculus* states that an integral $\int_a^b f(t) dt$ can be evaluated by the formula $F(b) - F(a)$, where F is any antiderivative for f .

This is actually only half of the theorem, however. The other half addresses the question, “For what functions f does an antiderivative exist?” It is interesting that the list includes *every continuous function*. In fact, given a continuous function f and a number a in its domain, a function G is defined by $G(x) = \int_a^x f(t) dt$, and the other half of the Fundamental Theorem states (among other things) that $G'(x) = f(x)$. Notice that this statement does not tell you how to find elementary formulas for antiderivatives; it merely asserts that *certain accumulation functions are antiderivatives*. Here are two examples:

(a) Suppose that an object moves with instantaneous speed $32t$ feet per second; how many feet does the object travel during the time interval $0 \leq t \leq x$?

(b) Suppose that an object moves with instantaneous speed $20e^{-t^2}$ feet per second; how many feet does the object travel during the time interval $0 \leq t \leq x$?

(c) It would be incorrect notation to write $G(x) = \int_a^x f(x) dx$. Do you see why?

2. (Continuation) Because a can be varied, many different antiderivatives for f can be obtained in the form $\int_a^x f(t) dt$. For instance, specify three of the functions represented by $\int_a^x \sin \pi t dt$. Find an antiderivative for $f(x) = \sin \pi x$ that cannot be obtained in this way.

3. (Continuation) Because of this close connection between integration and differentiation, integral signs are often used to denote antiderivatives. Thus statements such as $\int x^2 dx = \frac{1}{3} x^3 + C$ are common. The term *indefinite integral* often appears as a synonym for *antiderivative*, and $\int_5^8 x^2 dx$ is often called *definite*. Evaluate $\int e^{2x} dx$ and $\int_{-1}^1 e^{2x} dx$.

4. Without calculating decimals, show that $\int_1^2 \frac{1}{x} dx$ and $\int_5^{10} \frac{1}{x} dx$ have the same value.

5. As x varies from 0 to π , the values of $\sin x$ range between 0 and 1. If you had to calculate an *average* sine value for the interval $0 \leq x \leq \pi$, you might try adding a million representative sine values and dividing by a million: $\frac{1}{m} (\sin x_1 + \sin x_2 + \cdots + \sin x_m)$. Use your integration knowledge to predict a value for this calculation. (*Hint*: This expression looks very much like a Riemann sum, but it is not quite one. By doing some clever but simple algebra, rewrite the expression to make it a constant times a Riemann sum.)

6. (Continuation) Suppose that an object travels with varying speed $\sin t$ during the time interval $0 \leq t \leq \pi$. The familiar technique of calculating *average speed* is to divide the total distance by the total time. Carry out this plan to find the average speed of the object for this time interval. Compare your answer with the add-many-values method. Hmm . . .

7. Find constants a and c so that the expressions $\frac{x+2}{x^2-3x}$ and $\frac{a}{x} + \frac{c}{x-3}$ are equivalent.

This algebraic result should then allow you to evaluate $\int_4^7 \frac{x+2}{x^2-3x} dx$. This applies the *partial-fractions* approach to finding antiderivatives.

Mathematics 4C

1. Let $g(x) = \int_{\pi/2}^x \sin t \, dt$. Show that $g(3\pi/2) = 0$. For what x in $[0, 2\pi]$ is $g(x) < 0$?
2. There is a curve that fits the differential equation $\frac{dy}{dx} = x - y$ and goes through $(0, 1)$.
 - (a) What is the slope of this curve at $(0, 1)$?
 - (b) Explain why this differential equation is *not* separable.
 - (c) Use Euler's method to find $y(2)$ for the chosen curve.

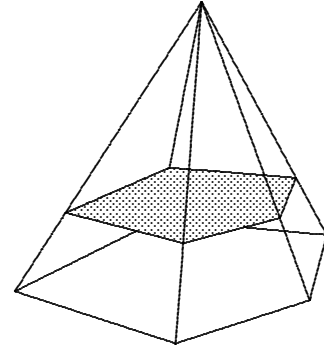

3. A pyramid that is h inches tall has a base whose area is B square inches. The pyramid is sliced by a plane that is y inches from the vertex and parallel to the base; let $A(y)$ be the area of the *cross-section*. Find a formula for $A(y)$. Your formula should tell you that $A(h) = B$ and $A(\frac{1}{2}h) = \frac{1}{4}B$. Evaluate $\int_0^h A(y) \, dy$. Explain the significance of the answer.

4. When liquid evaporates from a container, the rate of evaporation $\frac{dV}{dt}$ is proportional to the area of the exposed surface. Explain why the rate of decrease of liquid depth must therefore be constant.

5. If f is differentiable, the midpoint sum is also called the *tangent-line* sum. Why?

6. With $f(t) = \sin 4\pi t$ and $g(t) = 2 \cos 3\pi t$, verify that the *Lissajous curve* traced by the equations $x = f(t)$ and $y = g(t)$ (shown in part) goes through the origin $(0, 0)$ when $t = \frac{1}{2}$.

- (a) Even though $\frac{g(1/2)}{f(1/2)}$ makes no sense, $\frac{g(t)}{f(t)}$ does make sense for most other values of t , and the ratio approaches a limiting value m as t approaches $\frac{1}{2}$. Find m . What is its significance? It will help to think of $\frac{g(t)}{f(t)}$ as $\frac{g(t) - 0}{f(t) - 0}$.

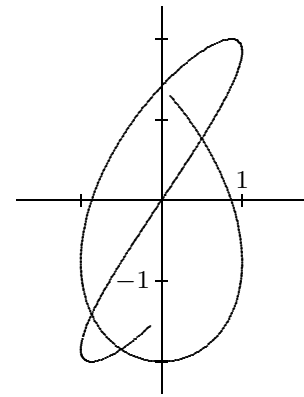

- (b) As t approaches $\frac{1}{2}$, the ratio of derivatives $\frac{g'(t)}{f'(t)}$ approaches the same limiting value m . Why could this have been expected?

7. Show that $f(x) = \ln 6x$ and $g(x) = \ln x$ have the same derivative. Could this have been expected? What does this tell you about the graphs of $y = \ln 6x$ and $y = \ln x$?

8. As x varies between 0 and 2, the value of x^2 varies between 0 and 4. What is the *average* of all these squared values?

9. (Continuation) Given that $f(x)$ is defined for all values of x between a and b , inclusive, what is the average of all the values $f(x)$?

10. Find constants a and b so that the expressions $\frac{5}{x(x+2)}$ and $\frac{a}{x} + \frac{b}{x+2}$ are equivalent.

Mathematics 4C

1. The figure shows the graph $y = f(x)$ of a periodic function, whose period is 12. The graph is built from segments and semicircular arcs. Notice the value $f(6) = -3$. A function g is defined for all x by $g(x) = \int_0^x f(t) dt$.

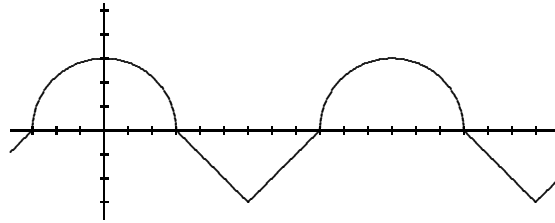

- (a) Calculate $g(9)$.
- (b) Find all values of x at which g has a relative maximum. Justify your answer.
- (c) Write an equation for the line that is tangent to the graph of g at $x = 6$.
- (d) Find the x -coordinates of each point of inflection on the graph of g .
- (e) Is g a periodic function? Justify your response.

2. Show that $y = x^{1/3}$ has an inflection point at $(0, 0)$. What is unusual here?

3. The diagram shows the *slope field* for the differential equation $\frac{dy}{dx} = y$, which assigns a slope to each point in the xy -plane. For example, the slope assigned to $(1.5, 1.25)$ is 1.25. In the diagram, a few of these slopes are represented by short segments. A slope field allows you to visualize the behavior of the solutions to a differential equation. In particular:

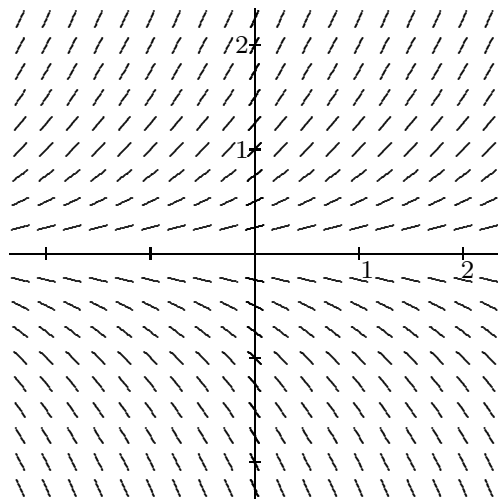

- (a) The diagram suggests that the equation has a constant solution $y = k$; what is k ?
- (b) Verify that $y = 0.5e^x$ is a solution to the differential equation. Use the slope field to help you sketch this curve.

4. Find the area of the “triangular” region enclosed by $y = \cos x$, $y = \sin x$, and $x = 0$.

5. Sketch the slope field for the differential equation $\frac{dy}{dx} = \sin x$. Notice that the slopes of this field depend only on x , not on y . Use your slope field to help you graph the solution curve that goes through the origin. Find an equation for this curve.

6. Find the area enclosed by $y = \frac{1}{1+x^2}$, the x -axis, and the lines $x = 1$ and $x = -1$.

7. Given the information $\frac{dy}{dx} = y$ and $y(0) = 1$, apply Euler’s method with 100 steps to find the value $y(1)$. You already know the true value of $y(1)$, of course.

8. The height of an object moving up and down is described by $y = k + a \cos(mt)$, where k , a , and m are all positive quantities. Show that the average speed of the object is $2/\pi$ times its greatest speed. How did you interpret “average speed”?

9. The line $x + 2y = 3$ intersects the curve $y = x^2$ perpendicularly at $(1, 1)$. Verify this. Use this line to help you find the radius of curvature of this parabola at $(1, 1)$.

Mathematics 4C

1. A function g is continuous on the interval $[-2, 4]$, with $g(-2) = 5$ and $g(4) = 2$. Its derivatives have properties summarized in the table:

x	$-2 < x < 0$	$x = 0$	$0 < x < 2$	$x = 2$	$2 < x < 4$
$g'(x)$	positive	undefined	negative	0	negative
$g''(x)$	positive	undefined	positive	0	negative

- (a) Find the x -coordinates of all globally extreme points for g . Justify your answer.
- (b) Find the x -coordinates of all inflection points for g . Justify your answer.
- (c) Make a sketch of $y = g(x)$ that is consistent with the given information.

2. The diagram shows the *slope field* for the differential equation $\frac{dy}{dx} = 0.8y \cdot (1 - y)$, which assigns a slope to each point in the xy -plane. For example, verify that the slope assigned to $(1.3, 1.5)$ is -0.6 . In the diagram, a few of these slopes are represented by short segments. A slope field allows you to visualize the behavior of the solutions to a differential equation. In particular:

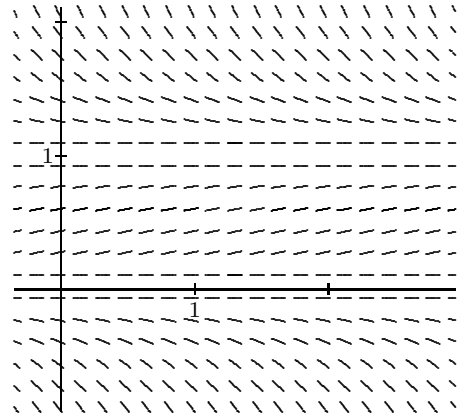

- (a) The diagram suggests that the equation has some constant solutions; what are they?
- (b) Verify that $y = \frac{2}{2 - e^{-0.8x}}$ is a solution to the differential equation. Use the slope field to help you sketch this curve.
- (c) If $y(x)$ is a solution to the differential equation, and if $y(0)$ is positive, what is the limiting value of $y(x)$ as x approaches infinity?

3. Without using a calculator, evaluate (a) $\int_0^\pi \cos t \, dt$ and (b) $\int_0^\pi |\cos t| \, dt$.

(c) Explain the difference between $\int_a^b f(t) \, dt$ and $\int_a^b |f(t)| \, dt$.

4. The acceleration of an object falling near the surface of the Earth is essentially constant. In fact, the height y of the object satisfies the differential equation $\frac{d^2y}{dt^2} = -32$, where position is measured in feet and time is measured in seconds. Suppose that an object is thrown downward at 112 fps at time $t = 0$ from an initial height of 2034 feet. Calculate y as a function of t , and the speed of the object as it strikes the ground.

5. The arc $y = \sqrt{x}$ for $0 \leq x \leq 4$ is revolved around the x -axis, thus generating a surface called a *paraboloid*, which is shown at right. Use integration to find the volume of this container.

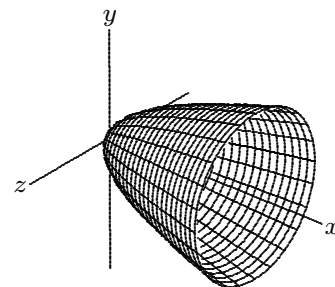

6. *L'Hôpital's Rule.* Let f and g be differentiable functions, and suppose that $f(a) = 0 = g(a)$. Then $\lim_{t \rightarrow a} \frac{g(t)}{f(t)} = \lim_{t \rightarrow a} \frac{g'(t)}{f'(t)}$, provided that the second limit exists. Explain why. Make up a new example that illustrates this technique for evaluating indeterminate forms.

Mathematics 4C

1. Use the Fundamental Theorem to evaluate $\int_0^{\pi/2} \cos x \sqrt{\sin x} dx$.
2. A 20-foot ladder is leaning against the side of a building. The base of the ladder is slipping away from the building at one inch per minute. How fast is the top of the ladder sliding down the wall when it is 16 feet above the ground?
3. Find constants a and b so that the expressions $\frac{x+3}{x^2-4}$ and $\frac{a}{x+2} + \frac{b}{x-2}$ are equivalent.

4. The figure shows the graph of f' , the derivative of a function f that is defined for all numbers in the interval $-6 \leq x \leq 14$.

(a) At what values of x between -6 and 14 is $f(x)$ a relative maximum? A relative minimum? Explain.

(b) For what values of x is the graph of $y = f(x)$ concave up? Explain.

(c) Given that $f(-6) = 2$, sketch a plausible graph of $y = f(x)$. Incorporate the results of parts (a) and (b) in your sketch.

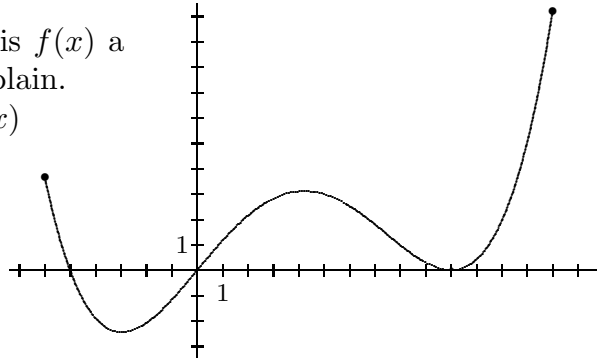

5. Sketch the slope field for the differential

equation $\frac{dy}{dx} = x - y$. Notice that the slopes along the line $y = x$ are all the same. The line $y = x$ is therefore called an *isocline* for this differential equation. What are the other isoclines? Use your slope field to help you graph $y = x - 1 + e^{-x}$, which is the solution curve that goes through the origin. Show that one of the solutions to the differential equation is a *linear* function. Apply a guess-and-check strategy to find an equation for another of the nonlinear solution curves.

6. Starting at the origin, Jamie walks along the positive y -axis while holding a 5-foot rope (which appears dotted in the diagram) that is tied to a wagon. The wagon is initially at $(5, 0)$. Its path is shown at right. The curve is an example of a *tractrix*.

(a) The path of the wagon includes the point $(3, 1.493)$. Where is Jamie when the wagon reaches this point?

(b) Explain how the differential equation $\frac{dy}{dx} = \frac{-\sqrt{25-x^2}}{x}$ defines the tractrix.

(c) Starting at $(5, 0)$, apply a 4-step Euler's method to find the y -value of the wagon when $x = 3$. Explain why you will need to use *negative* values for Δx . Also explain why you can be sure that your answer will be less than 1.493.

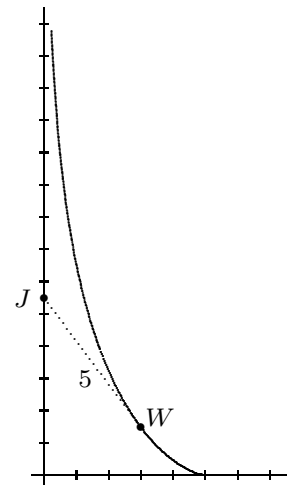

7. Give two reasons why $\int_a^b f(x) dx = -\int_b^a f(x) dx$ should be true.

8. Explain how the value of $\int_{-1}^1 \sqrt{1-x^2} dx$ can be obtained mentally. It should be just as easy to express the value of the definite integral $\int_{-a}^a \sqrt{a^2-x^2} dx$ in terms of a .

Mathematics 4C

1. To find the area enclosed by the curve $y = x^{2/3}$, the x -axis, and the lines $x = -1$ and $x = 8$, just evaluate $\int_{-1}^8 x^{2/3} dx$. Now notice that $y = x^{2/3}$ can be described by $(x, y) = (t^3, t^2)$, and apply this parametrization to the integral: Replace the interval from $x = -1$ to $x = 8$ by the interval from $t = -1$ to $t = 2$, and replace $y dx$ by $y \frac{dx}{dt} dt$. Do you get the same area?

2. Starting with a $2 \times 4 \times 4$ wooden block, Sasha sculpted an object that has isosceles, triangular cross-sections perpendicular to the 2×4 rectangular base. The height of each isosceles triangle equals its distance from the short end of the block. Draw the top view and two side views of this object, and include a three-dimensional coordinate system in your diagram. What is the volume of the object?

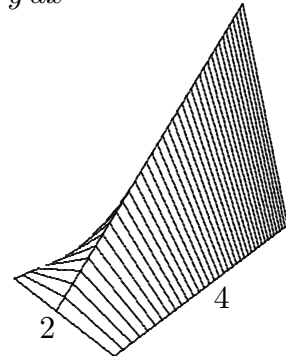

3. The human population of the Earth was 4.32 billion in 1978 and 5.76 billion in 1994. Assume that 12 billion is the maximum sustainable size, and calculate when the population will reach 10 billion. Use a logistic model $f' = m \cdot f \cdot (1 - f)$, in which the population $P(t)$ is expressed as a multiple $f(t)$ of 12. The data $f(0) = 0.36$ and $f(16) = 0.48$ is given.

4. Find the value of $\lim_{n \rightarrow \infty} \frac{1}{n} (e^{1/n} + e^{2/n} + e^{3/n} + \dots + e^{n/n})$. There are at least two ways to proceed.

5. The following definite integrals have something significant in common, which should enable you to evaluate each of them.

(a) $\int_0^3 \frac{2x}{1+x^2} dx$ (b) $\int_{\pi/4}^{\pi/2} \frac{\cos x}{\sin x} dx$ (c) $\int_{-1}^0 \frac{e^x}{3+e^x} dx$ (d) $\int_4^5 \frac{2x+3}{x^2+3x-4} dx$

6. The radius of a spherical container is r centimeters, and the water in it is h centimeters deep. Use an integral $\int_0^h A(z) dz$ to find a formula for the volume of water in the container. Check your formula on the special cases $h = 0$, $h = r$ and $h = 2r$.

7. Explain the geometric significance of the result $\int_0^R 4\pi x^2 dx = \frac{4}{3}\pi R^3$. In particular, contrast the way in which volume was accumulated in the preceding exercise with the way in which volume is being accumulated in this example.

8. Find a formula, in terms of a and b , for the area enclosed by the ellipse $\frac{x^2}{a^2} + \frac{y^2}{b^2} = 1$. Start by solving for y in terms of x , simplify the equation until the radical expression looks familiar, then evaluate an integral. This may remind you of a problem done in Math 3.

9. Apply l'Hôpital's Rule to the indeterminate form $\lim_{t \rightarrow 0} \frac{\sin at}{bt}$, with a and b constant.

10. Find the area of the region enclosed by the line $y = x + 2$ and the parabola $y = 4 - x^2$.

Mathematics 4C

1. Sasha took a wooden cylinder and created an interesting sculpture from it. The finished object is 6 inches tall and 6 inches in diameter. It has square cross-sections perpendicular to the circular base of the cylinder. Draw the top view and the two simplest side views of this sculpture. The volume of a thin slice of the object is approximately $A(x)\Delta x$, where $-3 \leq x \leq 3$. Explain. What is the volume of the object?

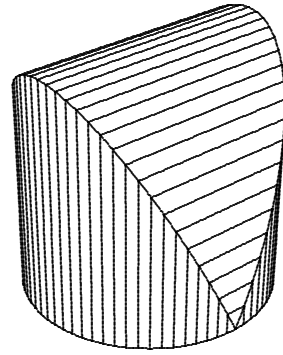

2. Check that $F(t) = \frac{1}{2}(t - \sin t \cos t)$ is an antiderivative for $f(t) = \sin^2 t$. Then find an antiderivative for $g(t) = \cos^2 t$.

3. Explain $\int_a^b f(x) dx + \int_b^c f(x) dx = \int_a^c f(x) dx$. Apply it by evaluating $\int_{-2}^3 |x^3 - 4x| dx$.

4. Use integration to find a formula, in terms of a and b , for the area enclosed by the ellipse $(x, y) = (a \cos t, b \sin t)$. Work parametrically. This means that the interval from $x = -a$ to $x = a$ should be replaced by the interval from $t = \pi$ to $t = 0$, and that $y dx$ should be replaced by $y \frac{dx}{dt} dt$. Enjoy the integral.

5. *The astroid.* Suppose that $P = (a, b)$ is a first-quadrant point on the curve $x^{2/3} + y^{2/3} = 1$. The line tangent to the curve at P crosses the x -axis at Q and the y -axis at R . Show that $Q = (a^{1/3}, 0)$. Show that the y -coordinate of R can be expressed in terms of b alone. Show that the length of segment QR does not depend on where P is on the curve. Finally, explain the name of this curve.

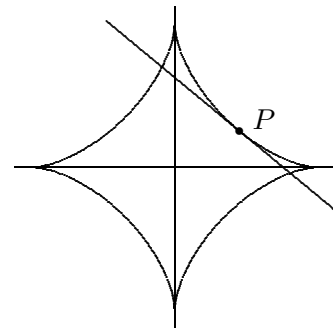

6. Verify that the line $y = 1 - x$ intersects the curve $y = \ln x$ perpendicularly at $P = (1, 0)$. Then let $P_a = (a, \ln a)$ be a nearby point on the same curve, and find an equation for the line that intersects the curve perpendicularly at P_a . Let R_a be the intersection of the two lines. In terms of a , find coordinates for R_a . What is the limiting position of R_a as a approaches 1? What does this limit point tell you about the shape of the curve near P ?

7. Choose a first-quadrant point $P = (a, b)$ on the hyperbola $xy = 1$. A right triangle is formed by the positive coordinate axes and the line through P that is tangent to the hyperbola. Show that the *area* of this triangle does not depend on where P is chosen on the curve. In other words, the area is independent of the value of a .

8. Suppose that f and g are functions, and that $f(x) \leq g(x)$ holds for $a \leq x \leq b$. What is one possible interpretation for the value of the integral $\int_a^b (g(x) - f(x)) dx$?

9. Find the area of the region enclosed by the line $y = x$ and the parabola $y = 2 - x^2$.

10. Find an antiderivative for the function defined by $g(x) = \frac{2x + 3}{x^2 + 3x - 4}$, applying the method of partial fractions. Notice that $x^2 + 3x - 4$ can be factored as $(x - 1)(x + 4)$.

Mathematics 4C

1. Because $g(x) = \frac{2x + 3}{x^2 + 3x - 4}$ has the form $\frac{f'(x)}{f(x)}$, it is called a *logarithmic derivative*. Explain the terminology. Notice that, although the method of partial fractions can be used to find an antiderivative for g , it is not actually needed.

2. For some functions f , the logarithmic derivative $\frac{f'(x)}{f(x)}$ is constant. Find three examples of such functions. Where have you encountered functions like these before?

3. Sasha's latest art project is shown at right. It has equilateral cross-sections perpendicular to an elliptical base that is 10 inches long and 6 inches wide. What is the volume of this sculpture?

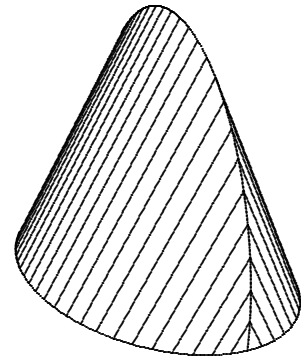

4. Sketch the slope field $\frac{dy}{dx} = -2xy$. Make use of isoclines, in particular those defined by the slopes -1 , 0 and 1 . Notice that most of the isoclines for this field are *not* straight lines. Now solve this separable differential equation, and add a few of its solution curves to your diagram.

5. Every calculus student knows two interpretations of *average velocity*. Do yours agree?

6. A falling object encounters air resistance, which retards its motion. The simplest model for this effect assumes that the resisting force is proportional to the speed of the object, as in the differential equation $\frac{dv}{dt} = -32 - 0.1v$, where the velocity v is measured in feet per second. Suppose that the object is dropped from a height of 1600 feet.

(a) This is a separable equation. After you separate the variables, antidifferentiate the equation to find the velocity of the object as an explicit function of t .

(b) Velocity is the derivative of position, so $v = \frac{dy}{dt}$, where y is the height of the object above the ground. Perform one more antidifferentiation to find y as a function of t .

(c) In effect, you have now solved a *second-order* differential equation by performing two successive antidifferentiations. Write the second-order equation.

7. The curve $(x, y) = (t^2, t^3 - t)$ is shown at right. Find the area enclosed by the loop in the graph. Remember that $y \, dx = y \frac{dx}{dt} \, dt$.

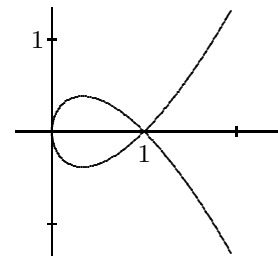

8. Given the positive constants a and b , evaluate $\int_a^b t^{-1} \, dt$.

9. Make a sketch of the region enclosed by the positive coordinate axes, the curve $y = e^{-x}$, and the line $x = a$, where a is a positive number. The area of this region depends on a , of course. For what value of a is the area of this region equal to 0.9? equal to 0.999? equal to 1.001? The expression $\int_0^\infty e^{-x} \, dx$ is an example of an *improper integral*. What is its numerical value, and how is this number to be interpreted?

Mathematics 4C

1. Being successful when using antidifferentiation to evaluate an integral often depends on recognizing the *form* of the *integrand*. To illustrate this remark, the following definite integrals have been chosen to have a common form. Evaluate each of them.

(a) $\int_6^{15} 2x\sqrt{64+x^2} dx$

(b) $\int_{\pi/3}^{\pi/2} \cos x\sqrt{\sin x} dx$

(c) $\int_0^1 e^x\sqrt{3+e^x} dx$

(d) $\int_1^e \frac{1}{x}\sqrt{\ln x} dx$

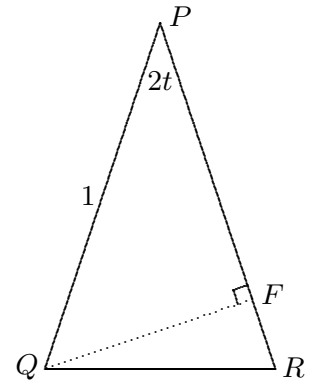

2. Every calculus student knows that $2\sin^2 t$ and $1 - \cos 2t$ are equivalent expressions. Here are three ways to believe this is true. *First:* Choose a random value for t and evaluate both expressions on your calculator. *Second:* As shown, consider an isosceles triangle PQR formed by two sides of length 1 that make an angle of size $2t$. Draw altitude QF , then write two different formulas for the length of segment FR . *Third:* The angle-addition formula $\cos(\alpha + \beta) = \cos \alpha \cos \beta - \sin \alpha \sin \beta$ is just what you need.

3. (Continuation) Show that $2\cos^2 t$ is equivalent to $1 + \cos 2t$.

4. Find the area enclosed by the x -axis and one arch of the cycloid defined by the parametric equation $(x, y) = (t - \sin t, 1 - \cos t)$. Remember to replace $y dx$ by $y \frac{dx}{dt} dt$.

5. A conical paper cup is 12 cm deep and has a 9-cm diameter. It is being filled with water at 60 cc per second. When the water is 8 cm deep, how fast is the water level rising?

6. Without evaluating either integral, explain why $\int_0^2 (8 - x^3) dx$ and $\int_0^8 \sqrt[3]{8-y} dy$ are sure to have exactly the same value. Then evaluate each and confirm your prediction.

7. Make up an example of a differential equation whose isoclines are parallel to the x -axis, and whose slopes vary between -2 and 2 , inclusive. Sketch some of the solution curves. If you can, find equations to describe them.

8. At what instantaneous rate is the water level rising in the following containers? In each, the volume of water is increasing at a steady 384 cc per second.

(a) The container is a cylinder; its base area is 240 square cm.

(b) The container is not a cylinder; the area of the water surface is 240 square cm.

9. What property of a function f guarantees that

(a) $\int_{-a}^a f(x) dx = 2 \int_0^a f(x) dx$ holds for all a ? (b) $\int_{-a}^a f(x) dx = 0$ holds for all a ?

10. It is evident that the first-quadrant branch of the hyperbola $xy = 4$ curves the most at the point $(2, 2)$. Calculate the *radius of curvature* at this point, in the usual way: Choose a point $P = \left(a, \frac{4}{a}\right)$ on the hyperbola near $(2, 2)$, find an equation for the line that is perpendicular to the hyperbola at P , let C be the intersection of this line with the line $y = x$, then let a approach 2 and watch what happens to C . Why is the line $y = x$ used?

Mathematics 4C

1. *The Never-ending Chimney.* Consider the curve $x = (1 + y)^{-1}$ for $0 \leq y \leq 5$. Revolve this arc around the y -axis to obtain a tubular surface, which can be thought of as a tapering chimney of height 5 and base radius 1. Find the volume of this chimney. Is it possible to double this volume by using a larger interval $0 \leq y \leq k$ to make a taller chimney?

2. A cylindrical tunnel of radius 3 inches is drilled through the center of a solid bowling ball of radius 5 inches. The volume of the ball used to be $500\pi/3$ cubic inches. What is the volume of the solid that remains after the drilling? (Notice that slices of this solid, made perpendicular to the tunnel axis, are all rings that have a hole of radius 3 inches.)

3. A searchlight L is turning at a steady rate, one complete revolution every two seconds. During each revolution, the beam moves along a straight wall CF , as shown in the top view at right. The point on the wall that is closest to L is C , 100 feet away, and point F is 260 feet from L . Verify that the spot of light is moving more than 300 feet per second when it passes C , then calculate the speed of the spot when it passes F .

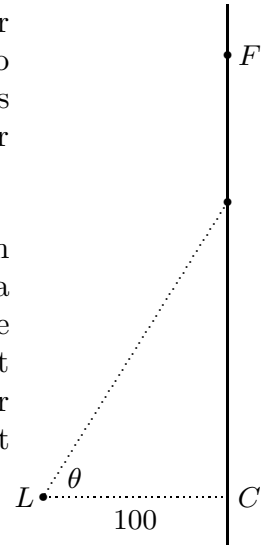

4. Evaluate the following indeterminate forms:

(a) $\lim_{x \rightarrow 0} \frac{a^x - b^x}{x}$

(b) $\lim_{x \rightarrow 0} \frac{x - x \cos x}{x - \sin x}$

(c) $\lim_{x \rightarrow 1} \frac{\ln x}{x - 1}$

5. Find an antiderivative for the function defined by $f(x) = x^{-1}$ that is valid for all nonzero values of x . There is more than one answer, of course.

6. You have recently evaluated a number of integrals of the form $\int_a^b \sqrt{u} \, du$. For example, $\int_1^e \frac{1}{x} \sqrt{\ln x} \, dx$ is equal to $\int_0^1 \sqrt{u} \, du$, where $u = \ln x$. Notice that $u = 1$ corresponds to $x = e$, and $u = 0$ corresponds to $x = 1$, which is why the limits on the two integrals are different. Make up an example that is equivalent to $\int_4^9 \sqrt{u} \, du$, by replacing u by an expression $f(x)$ of your choice. Choose corresponding integration limits for your dx integral, then find its value. This technique of transforming one integral into another that has the same value is known as *integration by substitution*.

7. Confronted by the integral $\int_0^{\ln 2} \frac{e^{-x}}{1 + e^{-x}} \, dx$, you might convert it to $\int_0^{\ln 2} \frac{1}{e^x + 1} \, dx$, by multiplying the numerator and the denominator by e^x . Is this actually a good idea?

8. Choose a point P on the x -axis and a point Q on the y -axis so that the distance from P to Q is exactly 1. Draw segment PQ . Repeat the preceding several more times, then try to imagine the result of drawing all such segments. Find a way to describe what you would see.

Mathematics 4C

1. If f is a periodic function, is it necessarily true that its antiderivative $\int_a^x f(t) dt$ is also periodic? If you think so, prove your assertion; if not, provide a counterexample.

2. Analyze the curve $y = e^x \sin x$ for $-\pi \leq x \leq \pi$. Make a careful sketch, identifying the relative extreme points and the inflection points. You should notice that this curve is closely related to the curves $y = e^x$ and $y = -e^x$. In what way?

3. A balloon is being inflated so that its volume increases steadily at 1000 cc per second. As it expands, the balloon maintains its shape — two hemispheres capping the ends of a cylinder whose length is three times its diameter. At what rate is the radius increasing at the instant when the radius reaches 6 cm?

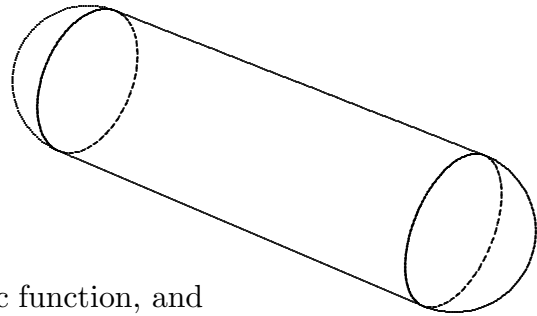

4. Let $p(x) = ax^2 + bx + c$ be a generic quadratic function, and $y_0 = p(-k)$, $y_1 = p(0)$, and $y_2 = p(k)$. Confirm that the average value of $p(x)$ on the interval $-k \leq x \leq k$ is $\frac{1}{6}(y_0 + 4y_1 + y_2)$, a weighted average of three evenly spaced values of $p(x)$. Because a , b , c , and k are arbitrary, this so-called *prismoidal formula* actually gives the average value of *any* quadratic function on *any* interval.

5. (Continuation) The trapezoidal method of numerically integrating a function f is to pretend that f is piecewise linear. Greater accuracy can be obtained by pretending that f is *piecewise quadratic*. For example, find a very good approximation to $\ln 2 = \int_1^2 \frac{1}{x} dx$ using just the five functional values $y_0 = 1$, $y_1 = \frac{4}{5}$, $y_2 = \frac{2}{3}$, $y_3 = \frac{4}{7}$, and $y_4 = \frac{1}{2}$. (Notice that the corresponding x -values are evenly spaced.) The first three y -values define a quadratic function whose average is easily calculated, and so do the last three.

6. To calculate a quadratic approximation to $\int_a^b f(x) dx$, using $\Delta x = \frac{b-a}{n}$ and $n+1$ uniformly spaced functional values $y_0 = f(a)$, $y_1 = f(a + \Delta x)$, \dots , and $y_n = f(b)$, where n is *even*, the literal recipe is

$$\frac{y_0 + 4y_1 + y_2}{6} \cdot 2 \frac{b-a}{n} + \frac{y_2 + 4y_3 + y_4}{6} \cdot 2 \frac{b-a}{n} + \dots + \frac{y_{n-2} + 4y_{n-1} + y_n}{6} \cdot 2 \frac{b-a}{n}.$$

This can be rewritten in the illuminating and more efficient form

$$\frac{y_0 + 4y_1 + 2y_2 + 4y_3 + 2y_4 + \dots + 4y_{n-1} + y_n}{3n} (b-a).$$

This is known as *Simpson's method*, or the *parabolic method*, of numerical integration. Confirm that the two formulas are equivalent, then find a meaning for the fraction that appears in the second formula.

Mathematics 4C

1. Write a differential equation that describes a curve whose tangent lines always meet the x -axis at a point that is one unit away from the point of tangency.

2. *The Mean-Value Theorem.* Suppose that f is continuous on the interval $a \leq x \leq b$, and that f is differentiable on the interval $a < x < b$. Draw the graph of f , and then draw the segment that joins $P = (a, f(a))$ to $Q = (b, f(b))$. Now consider all the lines that can be drawn tangent to the curve $y = f(x)$ for $a < x < b$. It is certain that at least one of these lines bears a special relationship to segment PQ . What is this relationship?

3. Walking along the x -axis, Jamie uses a rope of unit length to drag a wagon W that is initially at $(0, 1)$. Thus $W = (x, y)$ rolls along a tractrix. Suppose that Jamie walks in such a way that the speed of W is 1 unit per second. It follows that the velocity component $\frac{dy}{dt}$ of the wagon is exactly $-y$. Explain why this is so. You should also be able to express the component $\frac{dx}{dt}$ in terms of y . Show that $y = ke^{-t}$, for some positive constant k that does not exceed 1. What is the meaning of the constant k ?

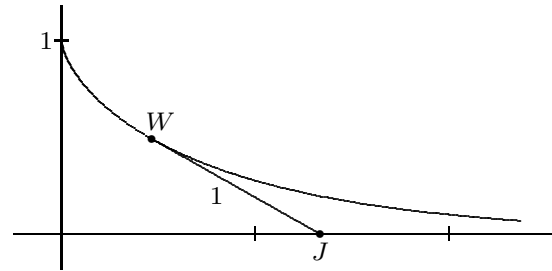

4. (Continuation) Given that $W = (x, y)$, explain why $J = (x + \sqrt{1 - y^2}, 0)$. Use this equation to calculate a formula for Jamie's speed, as a function of y .

5. The conclusion of the Mean-Value Theorem does not necessarily follow if f is not known to be a differentiable function. Provide an example that illustrates this remark.

6. The special case of the Mean-Value Theorem that occurs when $f(a) = 0 = f(b)$ is called *Rolle's Theorem*. Write a careful statement of this result. Does "0" play a significant role?

7. The derivative of a function that is constant on an interval is 0. A basic application of the Mean-Value Theorem is to prove the converse: If $f'(x) = 0$ for all x in some interval, then f must be a constant function on that interval. Supply the details of this argument.

8. (Continuation) If two functions have the same derivative, then they must differ by a constant on any interval on which they are both defined. Explain why.

9. Without using a calculator, evaluate $\int_{-6}^{-3} \frac{1}{x} dx$. Choose your antiderivative carefully.

10. A jet is flying at its cruising altitude of 6 miles. Its path carries it directly over Brook, who is observing it and making calculations. At the moment when the elevation angle is 60 degrees, Brook finds that this angle is increasing at 72 degrees per minute. Use this information to calculate the speed of the jet. Is your answer reasonable?

Mathematics 4C

1. A wheel of radius 1 is centered at the origin, and a rod AB of length 3 is attached at A to the rim of the wheel. The wheel turns in a counterclockwise direction, one rotation every 2π seconds, and, as it turns, the other end $B = (x, 0)$ of the rod is constrained to slide back and forth along a segment of the x -axis. The top figure shows this apparatus when $t = 0$, and $t = 1.02$ produces the bottom figure. Verify that, for any time t , the position of B is given by $x = \cos t + \sqrt{9 - \sin^2 t}$. When is B moving faster — when A is at the top of the wheel or when the rod AB is tangent to the wheel? Calculate $\frac{dx}{dt}$ to find out.

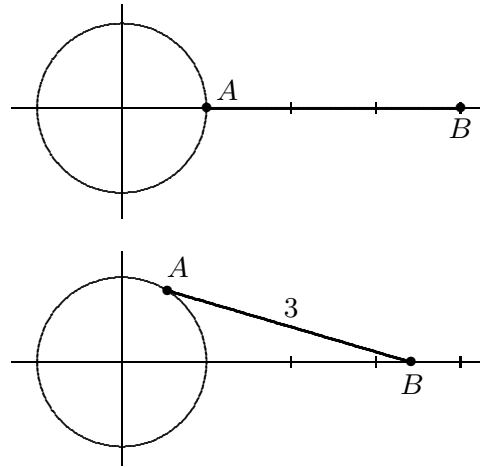

2. The driver of a red sports car suddenly decides to slow down a bit. The table at right shows how the speed of the car (in feet per second) changes second by second. Use Simpson's method (quadratic approximation) to calculate the distance traveled by the red sports car.

time	speed
0	110.0
1	99.8
2	90.9
3	83.2
4	76.4
5	70.4
6	65.1

3. Sketch the following slope fields, and find their solutions:

(a) $\frac{dy}{dx} = \frac{y}{x}$

(b) $\frac{dy}{dx} = \frac{2y}{x}$

4. Kelly completed a 250-mile drive in exactly 5 hours — an average speed of 50 mph. The trip was not actually made at a constant speed of 50 mph, of course, for there were traffic lights, slow-moving trucks in the way, etc. Nevertheless, there must have been at least one instant during the trip when Kelly's speedometer showed exactly 50 mph. Give two explanations — one using a distance-versus-time graph, and the other using a speed-versus-time graph. Make your graphs consistent with each other!

5. (Continuation) A student drew the line that joins $(0, 0)$ to $(5, 250)$, and remarked that any actual distance-versus-time graph has to have points that lie above this line *and* points that lie below it. What do you think of this remark, and why?

6. (Continuation) Another student was thinking that the area between the distance-versus-time graph and the time axis was a significant number. What do you think of this idea, and why?

7. The elliptical region $\frac{x^2}{a^2} + \frac{y^2}{b^2} \leq 1$ is spun around its major axis (the x -axis) to generate a solid called an *ellipsoid*. Find a formula (in terms of a and b) for its volume. What would the formula have looked like if the region had been spun around the minor axis? To check, notice that both formulas should look familiar in the special case $a = b$.

Mathematics 4C

1. A cylindrical tunnel of radius 3 inches is drilled through the center of a solid bowling ball of radius 5 inches. The solid that remains after the drilling can be partitioned into a system of nested cylindrical shells (or sleeves) of varying heights and radii. The tallest one is 8 inches tall; its radius is 3 inches. Make a drawing that shows three or four of these thin shells. Use this system of shells to show that the volume of the tunneled ball is $\int_3^5 2\pi x \cdot 2\sqrt{25 - x^2} dx$. Then evaluate the integral by means of antidifferentiation.
2. From the 1995 AP: A conical tank, with height 12 feet and diameter 8 feet, is draining point down so that the water depth h is changing at the rate of $h - 12$ feet per minute.
 - (a) At what rate is the volume of water in the tank changing when $h = 3$?
 - (b) Given that h is 10 when $t = 0$, express h as a function of t .
 - (c) The problem statement does not give a realistic description of a draining cone. To see why, assume that the cone was initially full, and try to express h as a function of t .
3. Can an isocline for a differential equation also be a solution curve for that equation?

4. An object moves according to parametric equations $x = 2 \cos t$ and $y = \sin t$. Verify that the object follows the ellipse $x^2 + 4y^2 = 4$ as t varies from 0 to 2π . Let P and Q be the points on the ellipse that correspond to the t -values 0.5 and 0.6, respectively. Calculate coordinates for P and Q , then calculate the components of the (short) vector that points from P to Q . Divide each component by 0.1, which produces a longer vector \mathbf{v} . Why was the divisor 0.1 chosen? What does \mathbf{v} represent?

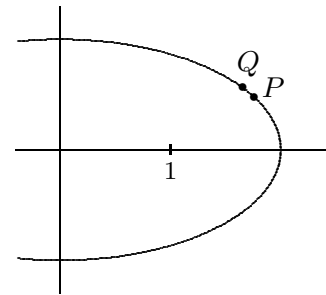

5. (Continuation) If Q had been calculated using $t = 0.501$ (making the divisor 0.001), then \mathbf{v} would have been slightly different. Consider the effect of using smaller and smaller time intervals Δt as you ponder the significance of the vector

$$[-2 \sin 0.5, \cos 0.5] = \lim_{\Delta t \rightarrow 0} \left[\frac{2 \cos(0.5 + \Delta t) - 2 \cos(0.5)}{\Delta t}, \frac{\sin(0.5 + \Delta t) - \sin(0.5)}{\Delta t} \right]$$

What is the meaning of this vector, and why can its magnitude $\sqrt{(-2 \sin 0.5)^2 + (\cos 0.5)^2}$ be thought of as the *speed* of the object as it passes P ?

6. (Continuation) Explain why $\int_0^{2\pi} \sqrt{4 \sin^2 t + \cos^2 t} dt$ is the circumference of the ellipse $x^2 + 4y^2 = 4$. Make use of your calculator's ability to approximate this integral.
7. The symmetry axes of the ellipse $3x^2 - 4xy + 3y^2 = 50$ are the lines $y = x$ and $y = -x$. Find the points on this curve that have the extreme y -values and the points that have the extreme x -values. There are four of them in all. Notice that some preliminary algebraic work is needed before you can graph this curve on your calculator.

Mathematics 4C

1. *Integration by Parts* is the name given to the Product Rule for derivatives when it is used to solve integration problems. The first step is to convert $(f \cdot g)' = f \cdot g' + g \cdot f'$ into the form $f(x)g(x) \Big|_{x=a}^{x=b} = \int_a^b f(x)g'(x) dx + \int_a^b g(x)f'(x) dx$. Explain this reasoning, then notice an interesting consequence of this equation: *If either of the integrals can be evaluated, then the other can be too.* Apply this insight to obtain the value of $\int_0^\pi x \cos x dx$. No calculator needed.

2. Let \mathcal{R}_k be the region enclosed by the positive coordinate axes, the curve $y = \sec^2 x$, and the line $x = k$, where k is a number between 0 and $\frac{1}{2}\pi$. Find the area of \mathcal{R}_k , and notice what happens to this area as $k \rightarrow \frac{1}{2}\pi$. Explain why the expression $\int_0^{\pi/2} \sec^2 x dx$ is called an improper integral. Does this expression have a numerical value?

3. Convince a skeptic that $\int_a^b k f(x) dx$ is equivalent to $k \int_a^b f(x) dx$ when k is a constant.

4. Notice that $\int_a^x f(t) dt$ and $\int_b^x f(t) dt$ are both functions of x . Verify that they have the same derivative. It follows that these functions differ by a constant. What is the constant?

5. If $(x(t), y(t))$ is a parametric curve, then $\left[\frac{dx}{dt}, \frac{dy}{dt} \right]$ is its velocity and $\sqrt{\left(\frac{dx}{dt}\right)^2 + \left(\frac{dy}{dt}\right)^2}$ is its speed. Find at least two parametrized curves whose speed is $\sqrt{t^4 - 2t^2 + 1 + 4t^2}$.

6. Recall the double-angle identity $\cos 2x = 1 - 2 \sin^2 x$. Obtain $-2 \sin 2x = -4 \sin x \cos x$ by applying D_x to both sides. What values of x satisfy this equation? Now start with the equation $x^2 - 4x = 3$ and obtain $2x - 4 = 0$ by applying D_x to both sides. Do the same values of x satisfy both of these equations? Explain.

7. In the diagram at right, $P = (\cos t, \sin t)$ and $A = (1, 0)$ are on the unit circle, and $Q = (1, t)$ makes tangent segment AQ have the same length as minor arc AP . (Why?) The line through P and Q intersects the x -axis at $R = (r, 0)$. The coordinate r depends on the value of t . Express r in terms of t , then check that the value of r when $t = 1.3$ agrees with the diagram. Does r approach a limiting value as t approaches 0? Explain. Remember to use radians.

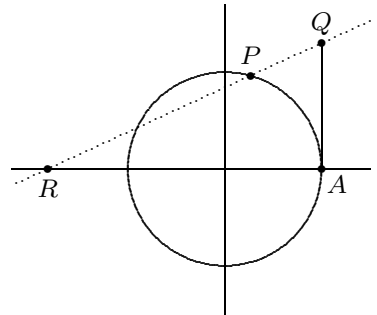

8. A particle travels along the ellipse $9x^2 + 25y^2 = 5625$ according to the parametric equation $(x, y) = (25 \cos t, 15 \sin t)$. Asked to find the speed of the particle as it passes the point $(15, 12)$, Lee obtained -0.45 by using the dy/dx calculator function. What do you think of this answer?

Mathematics 4C

1. Let \mathcal{R} be the region enclosed by the positive coordinate axes and the curve $y = \cos x$ for $0 \leq x \leq \frac{1}{2}\pi$. Find the volume of the solid that is formed by revolving \mathcal{R} around the y -axis. Do this twice — first use the cross-sectional method, then use the shell method.
2. Verify that $D_x \tan^2 x = D_x \sec^2 x$. What does this tell you about $\tan^2 x$ and $\sec^2 x$?
3. The integrals $\int_a^b \pi y^2 dx$ and $\int_a^b \sqrt{\left(\frac{dx}{dt}\right)^2 + \left(\frac{dy}{dt}\right)^2} dt$ are templates for what types of problem?
4. Given a function f , about which you know only $f(2) = 1$ and $f(5) = 4$, can you be sure that there is an x between 2 and 5 for which $f(x) = 3$? If not, what additional information about f would allow you to conclude that f has this *intermediate-value property*?
5. The driver of a red sports car, which is rolling along at 110 feet per second, suddenly steps on the brake, producing a steady deceleration of 25 feet per second per second. How many feet does the red sports car travel while coming to a stop?
6. Consider the integral $\int_0^{\pi/2} \tan x dx$. First explain why this is *improper*, then make calculations to determine whether the integral can be assigned a meaningful (finite) value.
7. Consider the integrals $\int_0^2 y dy$ and $\int_0^2 y dx$. One can be evaluated, but the value of the other one is not determined without additional information. Which is which, and why?
8. An object slides along the ellipse $x^2 - 2xy + 2y^2 = 10$. When it passes $(4, 3)$, the object's horizontal component of velocity is $\frac{dx}{dt} = 2$. What is the object's vertical component of velocity at that instant? In which direction is the object traveling around the ellipse, clockwise or counterclockwise?
9. (Continuation) Calculate the size of the angle formed by the velocity vector and the radial vector $[x, y]$ at the point $(4, 3)$. At this instant, is the object getting closer to the origin or receding from it?
10. (Continuation) Let r be the distance from the origin to the point (x, y) . When the object passes the point $(4, 3)$, what is the value of $\frac{dr}{dt}$? At this instant, is the object getting closer to the origin or receding from it?

Mathematics 4C

1. Students of calculus occasionally need to know an antiderivative for $\sec x$.

(a) Verify that $\ln|\sec x + \tan x|$ is one possible answer to the question.

(b) Write $\sec x \, dx$ as $\frac{\cos x \, dx}{\cos^2 x}$, which is the same as $\frac{\cos x \, dx}{1 - \sin^2 x}$, which has the form $\frac{du}{1 - u^2}$.

Now use the partial-fractions method to finish the job. Is $\ln|\sec x + \tan x|$ equivalent to your answer? If not, account for any discrepancy.

2. The diagram shows the parabolic arc $y = x^2$ inscribed in the rectangle $-a \leq x \leq a$, $0 \leq y \leq a^2$. This curve separates the rectangle into two regions. Find the ratio of their areas, and show that it does not depend on the value of a .

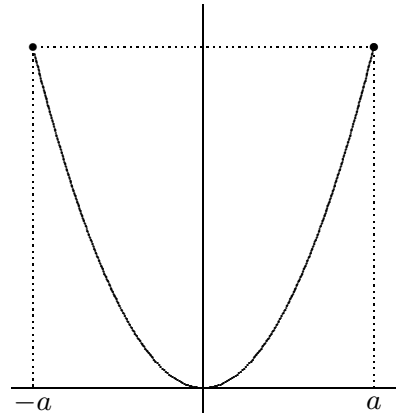

3. (Continuation) If you revolve the diagram around the y -axis, you will obtain a parabolic surface inscribed in a cylinder. This surface (called a *circular paraboloid*) separates the cylinder into two regions. Find the ratio of their volumes, and show that it does not depend on the value of a , either. Is it the same ratio as in the preceding question?

4. From Ryan's latest test: $\int_{-1}^1 \frac{1}{x^2} \, dx = -\frac{1}{x} \Big|_{x=-1}^{x=1} = -2$. What is your reaction?

5. Of all the straight lines that can be drawn through the point $(0, 1)$, the one that best fits the graph $y = \cos x$ is (of course) the tangent line $y = 1$. It is inviting to consider the problem of finding the *parabola* that best fits the curve $y = \cos x$ at the point $(0, 1)$. With this in mind, consider the quadratic function defined by $f(x) = ax^2 + bx + c$. Find the numbers a , b , and c that make f and its first two derivatives agree at $x = 0$ with the cosine function and its first two derivatives. Graph both functions for $-2 \leq x \leq 2$ on your calculator. Comment on what you see.

6. (Continuation) Both graphs have the same *radius of curvature* at $(0, 1)$. As a check on your work, verify that they do.

7. As shown in the diagram, a solid right circular cylinder of radius 12 cm is sliced by a plane that passes through the center of the base circle. Find the volume of the wedge-shaped piece that is created, given that its height is 16 cm.

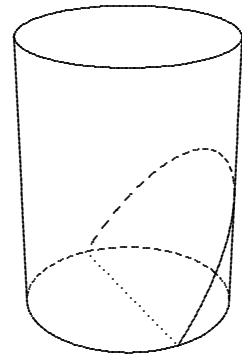

8. Find the total distance traveled by an object that moves according to the parametric equation $(x, y) = (\cos t + t \sin t, \sin t - t \cos t)$ from $t = 0$ to $t = \pi$.

9. Explain why $\int_0^1 \frac{6x}{(3x^2 + 1)^{3/2}} \, dx$ and $\int_0^{\pi/3} \frac{3 \sec \theta \tan \theta}{(-2 + 3 \sec \theta)^{3/2}} \, d\theta$ and $\int_e^{e^4} \frac{1}{t(\ln t)^{3/2}} \, dt$ all have the same value as $\int_1^4 u^{-3/2} \, du$. What is the common value of the four integrals?

Mathematics 4C

1. *Return of the astroid.* It can be difficult to deal with the equation $x^{2/3} + y^{2/3} = 1$. Verify that the curve can also be described as the path of an object that moves according to the parametric equations $x = \cos^3 t$ and $y = \sin^3 t$, for $0 \leq t \leq 2\pi$. Calculate the velocity and the speed of the object at time t . Simplify your speed formula to a form that is valid for all values of t . When (and where) is the object moving the fastest? Estimate the length of the astroid, then integrate the speed to find its exact length.

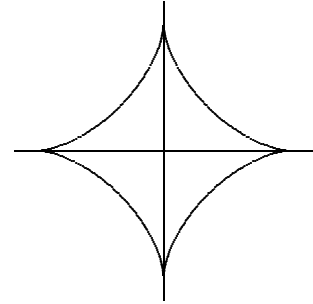

2. It is not immediately clear whether the integral $\int_4^5 x^2 \sqrt{x-4} dx$ can be evaluated by means of antidifferentiation. It *is* clear, however, that the problem would be much easier if $\sqrt{x-4}$ could be replaced by an expression like \sqrt{t} . It is therefore interesting to see the integral that results from applying the substitution $x = t+4$. Write the new integral, then find the common value of the two integrals.

3. (Continuation) Find an antiderivative for $f(x) = x^2 \sqrt{x-4}$.

4. Find the area of the region enclosed by the parabola $x = 4y - y^2$ and the line $y = x$.

5. Suspended from both ends, a stationary chain hangs against the south wall of a classroom. To estimate the length of the chain, a student makes measurements for nine points on the chain. The results (in feet) are shown at right. The entries in the first column are horizontal distances from the west wall, and the entries in the second column are heights above the floor. Using this data, estimate the length of the hanging chain.

<i>hori</i>	<i>vert</i>
1.0	7.00
2.0	3.29
3.0	1.28
4.0	0.29
5.0	0.00
6.0	0.29
7.0	1.28
8.0	3.29
9.0	7.00

6. Use integration by parts to evaluate the expression $\int_{-\pi}^{\pi} x \sin x dx$.

7. Every calculus student ought to know that $\sec^2 x$ and $1 + \tan^2 x$ are equivalent expressions. Justify the equivalence, then find an antiderivative for the function defined by $f(x) = \tan^2 x$.

8. We used integration by parts to evaluate $\int_0^k x^2 \sqrt{x} dx$. What do you think of this?

9. From the 2005 AP: A metal wire of length 8 cm is heated at one end. The table shows selected values $T(x)$ of the temperature (in degrees Celsius) of the wire, measured x cm from the heated end. Assume that T is a twice-differentiable, decreasing function.

x	$T(x)$
0	100
1	93
5	70
6	62
8	55

(a) Estimate $T'(7)$.

(b) Write an integral expression for the average temperature of the wire. Estimate this average by applying the trapezoidal method — using four trapezoids — to the data in the table.

(c) Is the assertion that $T''(x)$ is a positive function consistent with the data in the table? Justify your response.

Mathematics 4C

1. If your calculator's SOLVE feature ever stops working, you can use the *bisection method* to solve equations: Suppose that you know that $f(a) < 0$ and $0 < f(b)$, where f is continuous for $a \leq x \leq b$. Because continuous functions have the intermediate-value property, you can be sure of finding at least one solution to $f(x) = 0$ between a and b . Why? Now evaluate $f(m)$, where m is midway between a and b . If $f(m)$ is 0, the search is over. If not, the search continues in a smaller interval. Explain. Using this bisection method, how many steps will it take to narrow the search to an interval whose width is less than $\frac{1}{2000} |b - a|$?
2. Verify that $P_1(x) = \frac{1}{2} \sin^2 x$, $P_2(x) = -\frac{1}{2} \cos^2 x$, and $P_3(x) = -\frac{1}{4} \cos 2x$ are all antiderivatives for $p(x) = \sin x \cos x$. Reconcile these three answers to the same antiderivative problem.
3. Another *indeterminate form* that is frequently encountered in Calculus is $\frac{\infty}{\infty}$. First invent two limits that show that the expression $\frac{\infty}{\infty}$ is truly ambiguous. Then consider the following variant of *l'Hôpital's Rule*, in which the letter a stands for either a real number or ∞ : Suppose that f and g are differentiable functions, for which $\lim_{t \rightarrow a} f(t) = \infty$, $\lim_{t \rightarrow a} g(t) = \infty$, and $\lim_{t \rightarrow a} \frac{g'(t)}{f'(t)} = m$. Then $\lim_{t \rightarrow a} \frac{g(t)}{f(t)}$ also equals m . To make this statement at least seem *plausible* (a careful proof is difficult), make use of the curve defined by the equations $x = f(t)$ and $y = g(t)$. Explain what the ratios $\frac{g(t)}{f(t)}$ and $\frac{g'(t)}{f'(t)}$ represent.
4. Show that there are functions that fail to have the intermediate-value property.
5. *The Mean-Value Theorem for Integrals* says: If f is a function that is continuous for $a \leq x \leq b$, then there is a number c between a and b for which $f(c) \cdot (b - a) = \int_a^b f(x) dx$. Interpret this statement. Then, by applying the Fundamental Theorem of Calculus, show that the equation is actually a consequence of the Mean-Value Theorem for Derivatives.
6. Sketch the graph of $f(x) = \ln(1 + x)$ for $-1 < x$, noticing that the curve goes through the origin. What is the slope of the line that is tangent to the curve at the origin? What quadratic polynomial $p(x) = a_0 + a_1x + a_2x^2$ best fits the curve at the origin? What cubic best fits?
7. Write the definite integral that results from applying the substitution $x = \sin t$ to the integral $\int_{-1/2}^1 \sqrt{1 - x^2} dx$. Notice that there are *four* places where the substitution has to be used. What is the common value of the two integrals?
8. Evaluate the integral $\int_1^2 x^n dx$. Your answer will depend on the value of n , of course.
9. Evaluate $\int_1^2 \ln x dx$ by applying integration by parts to $\int_1^2 1 \cdot \ln x dx$.

Mathematics 4C

1. Let $P = (x, f(x))$ and $Q = (x + \Delta x, f(x + \Delta x))$ be two (nearby) points on the graph $y = f(x)$ that is shown at right.

(a) Explain why $\Delta x \sqrt{1 + (\Delta y/\Delta x)^2}$ is exactly the length of segment PQ .

(b) Show that there is a number c , between x and $x + \Delta x$, for which $f'(c) = \Delta y/\Delta x$. Use this to help you explain why the length of the curve is approximated to any degree of accuracy by Riemann sums for $\sqrt{1 + f'(x)^2}$.

(c) Explain why $\int_{-1}^1 \sqrt{1 + (2x)^2} dx$ is the length of the curve $f(x) = x^2$ for $-1 \leq x \leq 1$. Why would you expect this length to be greater than $2\sqrt{2}$? Use your calculator to obtain the value of the integral.

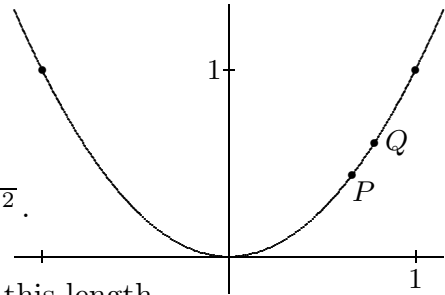

2. Find $\lim_{x \rightarrow \infty} x^3 e^{-x}$, then show that $\lim_{x \rightarrow \infty} x^n e^{-x}$ has the same value for any exponent n , including the examples $n = -2$, $n = 2006$, and $n = 3.75$.

3. Evaluate the definite integrals: (a) $\int_0^k e^{-x} dx$ (b) $\int_0^k x e^{-x} dx$ (c) $\int_0^k x^2 e^{-x} dx$. You will need to use integration by parts for the second and third examples. Your answers depend on the value of k . If k were a large positive number, what would the values of the integrals be?

4. Suppose that $f''(x) < 0$ on the interval $a \leq x \leq b$. Use the Mean-Value Theorem to explain why the graph of $y = f(x)$ for $a < x \leq b$ must lie below its tangent line at $P_a = (a, f(a))$. (*Hint*: Consider the slope of the chord from P_a to $P_x = (x, f(x))$.)

5. The example $\lim_{t \rightarrow \pi/2} \frac{\tan t}{\sec t}$ shows that you should not rely thoughtlessly on l'Hôpital's Rule. Explain why. Show that this example does not actually need a special theorem.

6. Looking out the window at the apartment building across the street, Alex watches a potted cactus fall to the street 400 feet below. Because of the varying angle of depression θ , it *seems* to Alex that the pot first speeds up, then slows down. After how many seconds does the pot seem to be falling the fastest? When you answer this question, assume that Alex is 160 feet from the apartment building, and that a falling object (which has been dropped) will have traveled $16t^2$ feet after falling for t seconds.

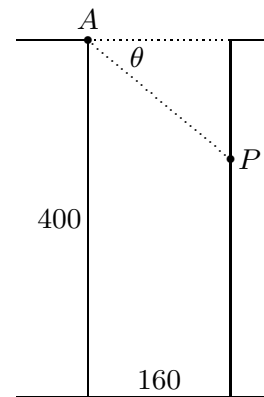

7. (Continuation) Would the critical value of t have been different if the height of the building had not been 400? What if the building separation were different from 160? Would the corresponding values of θ be affected?

8. To evaluate $\int_0^{\pi/2} e^{\sin x} \cos x dx$, Wes tried integration by parts. Was this a good idea?

Mathematics 4C

1. *Antidifferentiation by parts* is expressed $\int f(x)g'(x) dx = f(x)g(x) - \int f'(x)g(x) dx$ as a rule, but the equality sign has to be interpreted properly! To see why, consider the example formed by setting $f(x) = \sec x$ and $g(x) = -\cos x$.

2. Let $f(x) = 13 + 7x + \frac{19}{2}x^2 + \frac{31}{6}x^3 + \frac{5}{24}x^4$. Calculate $f(0)$, $f'(0)$, $f''(0)$, $f'''(0)$, $f^{(4)}(0)$, and $f^{(5)}(0)$ for this curve. Did you infer that $f^{(4)}(0)$ is shorthand for $f''''(0)$?

3. Find an equation for the fifth-degree polynomial $p(x)$ that has the following properties: $p(0) = 0$, $p'(0) = 1$, $p''(0) = 0$, $p'''(0) = -1$, $p^{(4)}(0) = 0$, and $p^{(5)}(0) = 1$.

4. (Continuation) Graph both $y = p(x)$ and $y = \sin x$ on the same coordinate-axis system for $-\pi \leq x \leq \pi$. Can you account for what you see?

5. Consider the tractrix that is traced by an object that is dragged with a rope of unit length, and let \mathcal{R} be the (unbounded) region that is surrounded by this curve and the positive coordinate axes. To find the area of \mathcal{R} , you might start with the template $\int_0^\infty y dx$, but you seem to be stuck without an explicit expression for y as a function

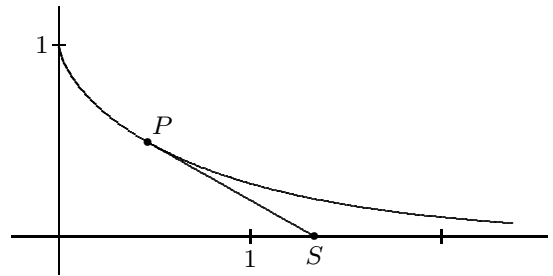

of x . Recall instead that the tractrix fits the differential equation $\frac{dx}{dy} = \frac{-\sqrt{1-y^2}}{y}$, which should enable you to convert this improper integral into an equivalent proper integral with respect to y . Evaluate this integral to find the area of \mathcal{R} .

6. (Continuation) Draw a rectangle $PQST$ for which PQ is parallel to the y -axis, and mark point R near P on diagonal PS . Mark A on QS so that RA is parallel to PQ , and mark B on ST so that RB is parallel to PT . Explain why the area of $PQAR$ is exactly the same as the area of $PTBR$. This fact should help you to justify the preceding equality of integrals.

7. (Continuation) An equation for the tractrix can be obtained in the form $x = g(y)$, by solving the antiderivative problem $dx = -\frac{\sqrt{1-y^2}}{y} dy$. (Notice the new appearance of this separable equation, in which “ dx ” and “ dy ” themselves have been separated; this form is favored by some writers.) Try the substitution $y = \cos \theta$.

8. (Continuation) If P is dragged so that it starts at $(0, 1)$ and moves at 1 unit per second, it is known that the y -coordinate of P is e^{-t} at time t . Express the x -coordinate of P in terms of t .

9. (Continuation) Revolve the tractrix around the x -axis to obtain a “trumpet”.

(a) What is the volume of the region inside the trumpet?

(b) How far into the mouth of the trumpet can you push a spherical ball of radius k ? In other words, find the center of such a ball. Use extreme k -values to check your formula.

Mathematics 4C

1. Explain why the integral $\int_0^8 \sqrt{1+x^{-2/3}} dx$ is *improper*. Then transform the integral by means of the substitution $x = t^3$, and observe that the resulting integral is proper! Evaluate it. By the way, the original integral can be evaluated without making this substitution.
2. Find the length of the curve $y = \frac{3}{2}x^{2/3}$ for $0 \leq x \leq 8$.
3. *Putting tangent lines to use.* When you graph $f(x) = x^3 - 3x - 1$, you see one positive x -intercept. Finding its value requires a special technique. Here is an efficient, recursive approach, discovered by Isaac Newton and others: Choose an initial approximation, say $x_0 = 2$. Write an equation for the line that is tangent to the graph of f at $x = x_0$, then calculate the x -intercept of this line and call it x_1 . Now apply the same tangent-line process to x_1 to obtain x_2 . Apply the process to x_2 to obtain x_3 . If eight-place accuracy is sufficient, you can stop now, because x_3 and the actual x -intercept differ by less than 0.0000000033.
4. Another *indeterminate form* that is often encountered in Calculus is $0 \cdot \infty$. For example, consider the expression $\lim_{x \rightarrow 0^+} x \ln x$. Show that the product $x \ln x$ can be rewritten to make the limit question take the $\frac{\infty}{\infty}$ form. The product can also be rewritten to make the limit question take the $\frac{0}{0}$ form; show how. You should find that l'Hôpital's Rule works well on one of these two versions, but not on the other. Use it to find the value of $\lim_{x \rightarrow 0^+} x \ln x$. The meaning of the notation $x \rightarrow 0^+$ is that x approaches 0 from the *right*, through positive values. Why is this restriction necessary?
5. (Continuation) Make up an example of an indeterminate form of the type $0 \cdot \infty$, whose value is different from the value you found for $\lim_{x \rightarrow 0^+} x \ln x$.
6. Given a polynomial $p(x) = a_0 + a_1x + a_2x^2 + \cdots + a_nx^n$, it is routine to verify that $p(0) = a_0$, $p'(0) = a_1$, and $p''(0) = 2a_2$. What about $p'''(0)$ and $p^{(4)}(0)$? In general, what is the value of the k^{th} derivative of p at 0?
7. In order to find an antiderivative for either **(a)** $f(x) = x^2 \sin x$ or **(b)** $g(x) = e^x \sin x$, it is necessary to use integration by parts *twice*. Use this method on both examples. Notice that a special approach is needed to complete the second example.
8. On the same system of axes, graph both $y = \cos x$ for $-\frac{1}{2}\pi \leq x \leq \frac{1}{2}\pi$ and the top half of the ellipse $x^2 + 2y^2 = 2$. It should look like these curves have approximately the same length. By setting up two definite integrals, show that the curves have *exactly* the same length.
9. Jamie tried to calculate the area enclosed by the unit circle, by slicing the region into thin strips parallel to the y -axis. The lengths of the strips are $2 \sin \theta$, where $0 \leq \theta \leq \pi$, so Jamie reasoned that the area is $\int_0^\pi 2 \sin \theta d\theta$. Explain why this answer is too large.

Mathematics 4C

1. *Maclaurin polynomials.* Given a differentiable function f , you have seen how to use the values $f(0)$, $f'(0)$, $f''(0)$, \dots to create polynomials that approximate f near $x = 0$. The coefficients of these polynomials are calculated using values of the derivatives of f . Namely, the coefficient of x^n is $a_n = \frac{1}{n!}f^{(n)}(0)$. Use this recipe to calculate the sixth Maclaurin polynomial $a_0 + a_1x + a_2x^2 + a_3x^3 + a_4x^4 + a_5x^5 + a_6x^6$ for the cosine function, and graph both the cosine function and the polynomial for $-4 \leq x \leq 4$.

2. The left half of the diagram below shows side views of nine containers, each having a circular cross section. The depth y of the liquid in any container is an increasing function of the volume of the liquid (and conversely). The right half of the diagram shows graphs of these nine functions. Match each container with its graph. It might help to consider $\frac{dV}{dy}$ or $\frac{dy}{dV}$.

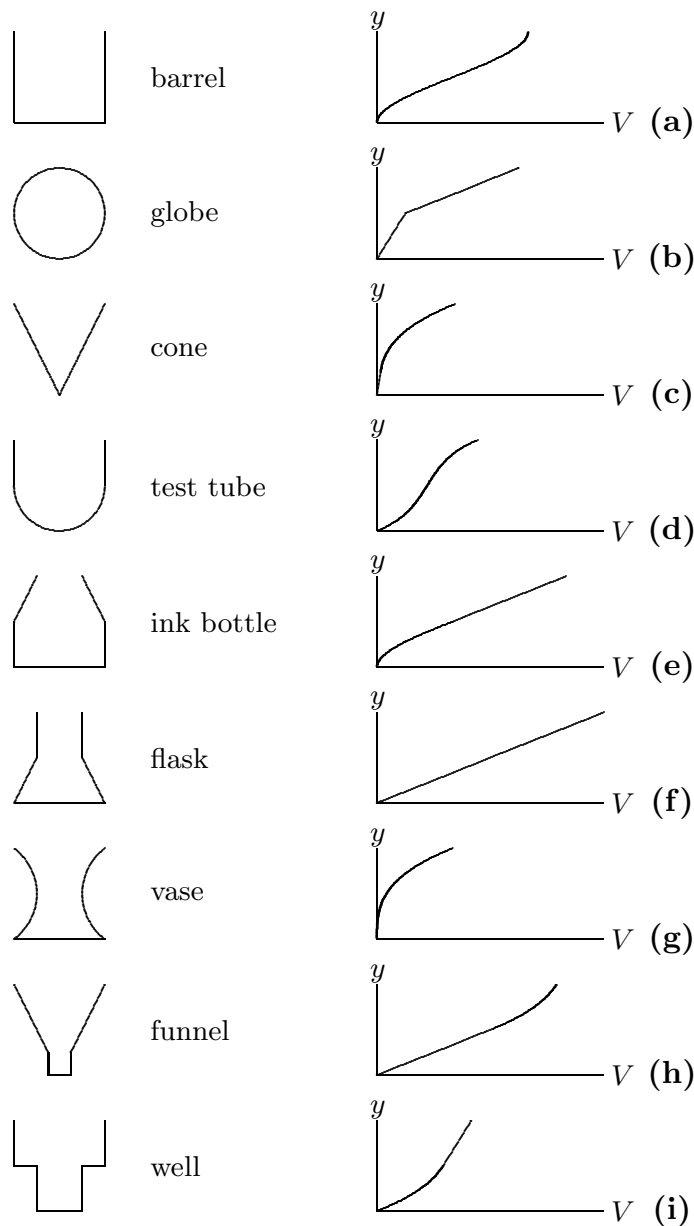

Mathematics 4C

1. The graph of $3x^2 + 5xy - 2y^2 = C$ is a hyperbola for any value of the constant C . The diagram shows the case $C = -8$. Use implicit differentiation to arrive at the slope field equation $\frac{dy}{dx} = \frac{5y + 6x}{4y - 5x}$. Sketch this field. It helps to notice that every line $y = mx$ is an isocline. Two of these isoclines are actually solutions to the differential equation. Find the slopes of these lines. Show that the lines bear a special relationship to the hyperbolas $3x^2 + 5xy - 2y^2 = C$.

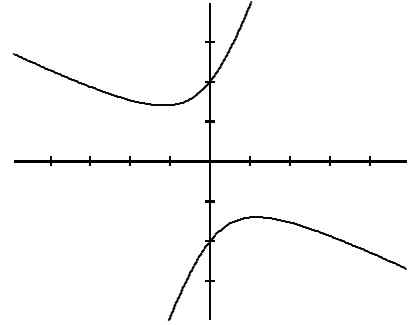

2. Consider a generic cubic graph $y = ax^3 + bx^2 + cx + d$, where a is nonzero. You may have noticed that such a graph has either two extreme points or none, and always one inflection point. Explain why. Then deduce that such a graph must have one, two, or three x -intercepts. Illustrate with pictures.

3. (Continuation) Is it possible for a quartic graph $y = ax^4 + bx^3 + cx^2 + dx + e$ to have exactly *two* extreme points? Justify your answer.

4. *Newton's Method* for solving an equation $f(x) = 0$ is a recursive process that begins with an initial guess x_0 . The line tangent to the graph of $y = f(x)$ at the point $P = (x_0, f(x_0))$ intersects the x -axis at $Q = (x_1, 0)$. Show that $x_1 = x_0 - \frac{f(x_0)}{f'(x_0)}$. Because this new value x_1 can itself be regarded as a guess, the tangent-line calculation can be repeated to obtain x_2, x_3 , etc. Write a recursive description of this sequence.

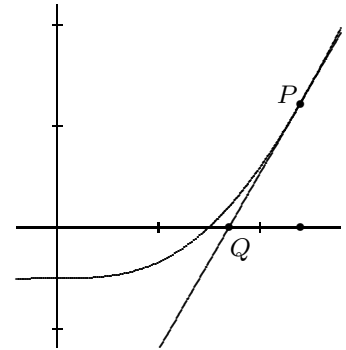

5. Use Newton's Method to solve $x - \sin x = 0.5$. This means finding the unique zero of the function defined by $f(x) = x - \sin x - 0.5$, part of whose graph is shown above. As suggested by the figure, start with the guess $x_0 = 2.4$, and stop when you get to x_4 , which will be accurate to seven decimal places.

6. Evaluate $\int_1^k x^n \ln x \, dx$. Your answer will depend on both k and n , of course.

7. Evaluate $\int_0^{\pi/2} \cos^3 t \, dt$. Do it first by using integration by parts, and then do it without using integration by parts.

Mathematics 4C

1. Given $y = \sqrt{r^2 - x^2}$, it is possible to calculate y'' explicitly, if one is careful with the Chain Rule, the Product Rule, and signs. It is also possible to obtain y'' implicitly, by starting with the equation $x^2 + y^2 = r^2$, where r is a constant. Carry out both methods and compare your results. In particular, find the value of y'' when $x = 0$ (and $y = r$).

2. Apply the substitution $x = \tan \theta$ to the definite integral $\int_1^2 \frac{4}{x(x^2 + 1)} dx$. In other words, create a new integral by *replacing* all occurrences of x by $\tan \theta$. Notice that it is necessary to change the limits of integration along with everything else. Use your calculator to confirm that both integrals have the same numerical value. Which of the two integrals can be evaluated directly by means of antiderivatives?

3. Show that $\frac{4}{x(x^2 + 1)}$ can be written as a sum $\frac{a}{x} + \frac{bx}{x^2 + 1} + \frac{c}{x^2 + 1}$ of simple fractions, by finding suitable values for a , b , and c . Use this equivalent expression to evaluate $\int_1^2 \frac{4}{x(x^2 + 1)} dx$.

4. Given a differentiable curve $y = f(x)$ for $a \leq x \leq b$, its length is $\int_a^b \sqrt{1 + f'(x)^2} dx$. Explain why, then do the following example: Sketch $y = x^{3/2}$ for $0 \leq x \leq 4$, estimate the length of this curve, and use integration to find its exact length.

5. Show that the length of the semicircular arc $y = \sqrt{1 - x^2}$ for $-1 \leq x \leq 1$ can be described by the definite integral $\int_{-1}^1 (1 - x^2)^{-1/2} dx$. Explain why this integral is called *improper*. Use the Fundamental Theorem of Calculus (*i.e.* find an antiderivative) to show that this integral has the predictable value.

6. The integral $\int_0^{\pi^2} \cos \sqrt{x} dx$ can be evaluated using integration by parts, *after* the preliminary substitution $x = t^2$ has been applied. Show how.

7. Because $\int_0^k e^{-x} dx$ approaches 1 as k approaches ∞ , it is customary to summarize this by writing $1 = \int_0^{\infty} e^{-x} dx$. One says that the improper integral $\int_0^{\infty} e^{-x} dx$ *converges* to 1. Show that $\int_0^{\infty} x e^{-x} dx$ also converges to 1, and that $\int_0^{\infty} x^2 e^{-x} dx$ converges to 2. Reasoning recursively, find a simple formula for $\int_0^{\infty} x^n e^{-x} dx$ when n is a positive integer.

8. Show that the improper integral $\int_1^{\infty} \frac{1}{x} dx$ does *not* converge to a finite value. It *diverges*.

Mathematics 4C

1. Find the radius of curvature of a cycloid at its highest point. First make an intuitive guess, then do the limit process to see whether your guess is correct.
2. Show that $\int_0^\pi \sin x \, dx = \int_0^\pi |\sin 3x| \, dx$. After you finish your integral calculations, find an intuitive explanation why $\int_0^\pi \sin x \, dx = \int_0^\pi |\sin mx| \, dx$ is in fact true for any positive integer m .
3. If f is a function whose derivative Df is an even function, then the graph $y = f(x)$ must have half-turn symmetry about its y -intercept. Explain why.
4. Use polar coordinates $(r; \theta)$ and radian mode in the following: Consider the spiral described by $r = b^\theta$, and let $A = (r_0; \theta_0)$ be the point where it intersects the circle $r = r_0$; this means that $r_0 = b^{\theta_0}$. Suppose that h is a small positive number, and let $B = (r_0; \theta_0 + h)$ and $C = (b^{\theta_0+h}; \theta_0 + h)$. The points A , B , and C are very close together. Which ones lie on the spiral, and which ones lie on the circle? Notice that microscopic triangle ABC is right-angled. Simplify the ratio $\frac{b^{\theta_0+h} - r_0}{hr_0}$, then use it to find the angle formed at A by the spiral and the circle. Notice that this angle does not depend on r_0 . For what b is this angle $\frac{1}{4}\pi$ radian?
5. By now you are familiar with the exponential growth model described by the differential equation $\frac{dP}{dt} = kP$. This model unrealistically assumes that resources are unlimited. One equation that imposes a ceiling on the size of the population is the logistic model, illustrated by $\frac{dP}{dt} = 0.05 \left(1 - \frac{P}{6000}\right) P$. What happens to the rate of growth of such a population when P approaches the value 6000? Graph solution curves that result from the initial conditions $P_0 = 1000$ and $P_0 = 10000$.
6. Show that $\int_0^e \ln x \, dx = 0$. What would happen if $\ln x$ were replaced by $\log_b x$?
7. Explain why the approximation $\sqrt{1-x} \approx 1 - \frac{1}{2}x$ is as good as a linear approximation can be for small values of x . Deduce that the approximation $\sqrt{1-x^2} \approx 1 - \frac{1}{2}x^2$ is even better for small values of x . It may be interesting to recall that you have already done calculations (a while ago) that show that the circle of curvature at $(0, 1)$ for the parabola $y = 1 - \frac{1}{2}x^2$ is the unit circle!
8. For any positive integer m , the length of the curve $y = \sin x$ for $0 \leq x \leq \pi$ is the same as the length of the curve $y = \frac{1}{m} \sin mx$ for $0 \leq x \leq \pi$. Show this by writing integral expressions for the two lengths, then making a simple substitution in one of them. Do not look for antiderivatives. Also try to find an intuitive explanation. Draw a diagram for the case $m = 3$.

Mathematics 4C

1. Graph $y = \arctan\left(\frac{1+x}{1-x}\right)$ and calculate its derivative. You should notice a coincidence; what can you conclude from it? Finally, evaluate $\int_{-1}^1 \arctan\left(\frac{1+x}{1-x}\right) dx$.

2. There are many kinds of *ovals* — closed, simple, convex curves that have two perpendicular symmetry axes of different lengths. Ellipses are the best-known examples of such curves, but there are others. Invent (by means of an equation) a non-elliptical oval.

3. One way to measure the “ovalness” of an oval is the ratio b/a of its principal dimensions, where $2a$ is the length of its major axis and $2b$ is the length of its minor axis. Another way is to calculate the relative difference of these lengths, which is $(a-b)/a$. Contrast these formulas with the *eccentricity* $e = c/a$ for an ellipse (recall that $2c$ is the distance from one focus to the other, which makes sense only for an ellipse). Review your knowledge of ellipses and show that $b/a = \sqrt{1-e^2} \approx 1 - \frac{1}{2}e^2$, and that $(a-b)/a \approx \frac{1}{2}e^2$, for small values of e . For an ellipse, which of the three ratios do you think does the best job of measuring ovalness?

4. In the time of Johannes Kepler, it was believed that the orbit of Earth was circular, whereas the orbit of Mars was believed to be an oval (perhaps an ellipse), whose minor axis is 0.5% shorter than its major axis, so $(a-b)/a \approx 0.005$. It was also known that the Sun is not at the center of this orbit; it is offset by about 10% of a . Kepler knew the geometry of ellipses very well, and recognized that this information made it quite likely that the orbit of Mars was actually an ellipse. Explain how he might have reached this conclusion (which was confirmed theoretically by Isaac Newton a half-century later).

5. When the graph of $z = e^{-x^2}$ is revolved around the z -axis, a surface in xyz -space is formed. Find the volume of the region that is found between this surface and the xy -plane.

6. *The folium of Descartes.* The diagram shows the graph of $x^3 + y^3 - 3xy = 0$. This curve can be parametrized very neatly by intersecting it with lines $y = tx$ through the origin. Namely, given almost any line $y = tx$ of slope t , there is one point other than the origin where the line intersects the curve (the diagram should make that plausible), and the coordinates of this point P_t can each be expressed in terms of t . Find formulas for this parametrization, and explain why there is one exceptional value of t .

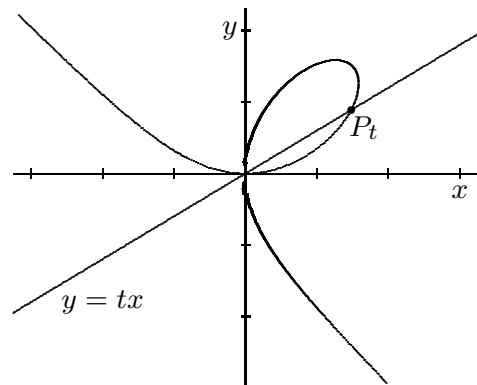

Mathematics 4C

1. Consider the following two procedures for drawing a random chord in the unit circle:
- (a) Choose a random number x between -1 and 1 , then draw the chord through $(x, 0)$ that is parallel to the y -axis.
- (b) Choose a random point *on* the circle by choosing a random polar angle θ between 0 and 2π , then draw the chord that is parallel to the y -axis and that goes through this point. Each of these methods was used to draw millions of random chords. For each method, what was the *average length* of the chosen chords?

2. Any straight line through $(0, 0)$ is an isocline for the differential equation $\frac{dy}{dx} = \frac{2x - y}{x + 3y}$. Explain why.

3. (Continuation) Show that $y = mx$ is a solution to $\frac{dy}{dx} = \frac{2x - y}{x + 3y}$ when $m = \frac{2 - m}{1 + 3m}$. Find the two values of m .

4. The graph of the quadratic equation $ax^2 + bxy + cy^2 = d$ has half-turn symmetry at the origin. Explain why, then conclude that the graph cannot be a parabola.

5. (Continuation) It can be proved that the graph of a quadratic equation $ax^2 + bxy + cy^2 = d$ is an ellipse, a hyperbola, a pair of parallel lines, or empty — it all depends on the values of a , b , c , and d . The diagram shows the case $a = 3$, $b = -6$, $c = 5$, and $d = 30$.

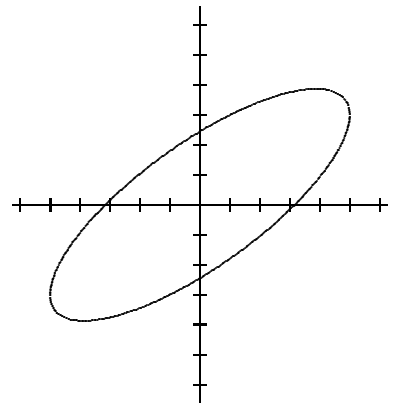

(e) Assuming the result just stated, deduce that the graph of $ax^2 + bxy + cy^2 = d$ is an ellipse whenever $b^2 - 4ac$ is negative and ad is positive. (*Hint*: Every line $y = mx$ must intersect an ellipse centered at the origin.)

(h) How can you tell when the graph of $ax^2 + bxy + cy^2 = d$ is a hyperbola? Provide an example.

(n) How can you tell when the graph of $ax^2 + bxy + cy^2 = d$ is a pair of parallel lines? Invent an example of such an equation.

6. Sketch the curve $y = x^{2/3}$ for $0 \leq x \leq 8$, and estimate its length. Show that the length of this curve is expressible as $\int_0^8 \frac{1}{3}x^{-1/3}\sqrt{9x^{2/3} + 4} dx$. Also explain why this integral is called *improper*. Then evaluate the integral by means of antidifferentiation.

7. *Average chord length.* Consider all the chords of the unit circle that can be drawn from $(1, 0)$. First show that the length of the chord drawn from $(1, 0)$ to $(\cos t, \sin t)$ is $2 \sin(t/2)$. If one million t -values were randomly chosen between 0 and 2π , and the corresponding chords were drawn, what (approximately) would the average of their lengths be?

8. Evaluate: (a) $\int_1^e x^a \ln x dx$ (b) $\lim_{t \rightarrow 0} \frac{c^{2+t} - c^2}{t}$ (c) $\int_4^{h^2} \frac{1}{x - \sqrt{x}} dx$

Your answers should be in terms of a , c , e , and h .

Mathematics 4C

1. Consider a cubic polynomial $y = x^3 + ax^2 + bx + c$. Show that there is a horizontal translation that carries the graph of this equation onto the graph of a cubic equation $y = x^3 + mx + n$, where the coefficients m and n depend in a specific way on the coefficients a , b , and c . Where is the inflection point of the second cubic? Show that the second cubic has half-turn symmetry about its point of inflection. What does this tell you about the inflection point of the first cubic curve?

2. Without loss of generality, the study of cubic curves can be restricted to the examples in the form $y = x^3 + mx + n$. Notice that such a curve has three different x -intercepts when the y -values of the extreme points lie on opposite sides of the x -axis. Show that this happens exactly when $\frac{1}{4}n^2 + \frac{1}{27}m^3 < 0$. The quantity $\frac{1}{4}n^2 + \frac{1}{27}m^3$ is called the *discriminant* of the cubic.

3. Given a geometric figure, one can ask for its *centroid*, which is — roughly speaking — the average of the points enclosed by the figure. Consider the unit semicircle $0 \leq y \leq \sqrt{1 - x^2}$, for example. The centroid is usually denoted by coordinates (\bar{x}, \bar{y}) . The y -axis symmetry of this example makes it clear that $\bar{x} = 0$, thus only \bar{y} needs to be calculated. To this end, imagine that a large number M of points has been scattered uniformly throughout the region.

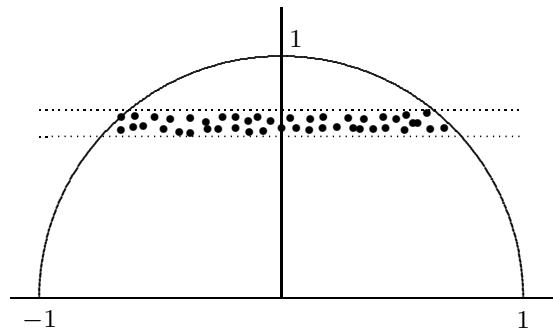

(a) To reduce the labor needed for this long calculation, it is convenient to divide the region into many thin horizontal strips, each of width Δy . Given any one of these strips, it is reasonable to use the *same* y -value for every one of the points found within the strip. What y -value would you use, and why is this step both convenient and reasonable?

(b) Suppose that $y = 0.6$ represents a horizontal strip. Show that this strip contains about $\frac{2(0.8)\Delta y}{\pi/2} M$ of the points, and that it therefore contributes $(0.6)\frac{2(0.8)\Delta y}{\pi/2} M$ to the sum.

(c) If the horizontal strips are represented by the values y_1, y_2, y_3, \dots , and y_n , then the *average* of the y -coordinates of *all* the points in *all* the strips is approximately

$$\left(y_1 \frac{2x_1 \Delta y}{\pi/2} M + y_2 \frac{2x_2 \Delta y}{\pi/2} M + y_3 \frac{2x_3 \Delta y}{\pi/2} M + \dots + y_n \frac{2x_n \Delta y}{\pi/2} M \right) \frac{1}{M},$$

where each $x_i = \sqrt{1 - y_i^2}$. Justify this formula. What is the meaning of each numerator $2x_i \Delta y$? What is the meaning of each fraction $\frac{2x_i \Delta y}{\pi/2}$? What does *weighted average* mean?

(d) Explain why you can obtain \bar{y} by calculating $\frac{4}{\pi} \int_0^1 y \sqrt{1 - y^2} dy$. Evaluate this integral, and check to see that your answer is reasonable.

Mathematics 4C

1. Find the third Maclaurin polynomial for $f(x) = \sqrt{1+x}$, and use it to approximate $\sqrt{1.8}$. How could you obtain a more accurate approximation?
2. Find antiderivatives for $f(x) = \cos x \sin^4 x$ and $g(x) = \cos^3 x \sin^4 x$.
3. The value of the improper integral $\int_0^4 \frac{e^{\sqrt{x}}}{\sqrt{x}} dx$ is defined to be $\lim_{k \rightarrow 0^+} \int_k^4 \frac{e^{\sqrt{x}}}{\sqrt{x}} dx$. Evaluate this one-sided limit.
4. Consider the slope field $\frac{dy}{dx} = \sin x$. Euler's method, when applied to the initial condition $y(0) = 0$, produces an approximation for $y(1)$. Show how to interpret this process as finding a *left-hand* Riemann sum for $y(1) = \int_0^1 \sin x dx$. Illustrate using step size $\Delta x = 0.1$.
5. The *Maclaurin series* for a function f is $\sum_{n=0}^{\infty} a_n x^n$, whose coefficients a_n are defined by the formula $a_n = \frac{1}{n!} f^{(n)}(0)$. Notice that the *partial sums* (subtotals) of this series are the Maclaurin polynomials for f . Calculate the Maclaurin series for five important examples:
(a) $\sin x$ (b) $\cos x$ (c) e^x (d) $\ln(1+x)$ (e) $\frac{1}{1-x}$
In other words, write out a few terms, then express the whole series in sigma notation.
6. (Continuation) A Maclaurin series $\sum_{n=0}^{\infty} a_n x^n$ *converges* if its partial sums converge to a limit, called the *sum* of the series. The sum is actually a function of x — it depends on the value of x . In particular, the series might not have a sum for some values of x . This is the case for two of the five examples in the preceding. Which two? For one of the five examples, you have already learned how to find the sum of the series. Which example?
7. Working term by term, find the derivative of the following Maclaurin series:
(a) $\sin x$ (b) $\cos x$ (c) e^x (d) $\ln(1+x)$
8. In the Maclaurin series for e^x , replace each occurrence of x by $i\theta$, assuming that it is meaningful to do so. Regroup the terms to put the result into $a + bi$ form.
9. There is a unique positive number k for which the improper integral $\int_0^k \frac{\ln x}{2\sqrt{x}} dx$ is equal to 0. Use integration by parts to find it.
10. Apply the substitution $x = u^2$ to the integral $\int_1^4 \frac{1}{(1+x)\sqrt{x}} dx$. This should enable you to find an exact expression for its value in terms of elementary functions.

Mathematics 4C

1. You have recently applied your knowledge of integration to calculate the centroid coordinate \bar{y} for the semicircular region $0 \leq y \leq \sqrt{1-x^2}$. Instead of slicing the region into horizontal strips, however, you could have sliced it into *vertical* strips — each of width Δx — and still have obtained the same value for \bar{y} .

(a) Given any one of these strips, it is reasonable to represent it by a single x -value. Which x -value would you choose, and why? This x -value determines the range of possible y -values that occur within the strip. What is this range?

(b) Suppose that $x = 0.6$ represents a vertical strip. Show that this strip contains about $\frac{0.8\Delta x}{\pi/2}M$ of the points. The *sum* of the y -coordinates of these points would be *essentially* unchanged if they were all replaced by a *single* y -value. Find this y -value, then use it to calculate the contribution of this strip to the sum of all the y -values.

(c) If the vertical strips are represented by the values x_1, x_2, x_3, \dots , and x_n , then the *average* of the y -coordinates of *all* the points in *all* the strips is approximately

$$\frac{y_1}{2} \cdot \frac{y_1 \Delta x}{\pi/2} + \frac{y_2}{2} \cdot \frac{y_2 \Delta x}{\pi/2} + \frac{y_3}{2} \cdot \frac{y_3 \Delta x}{\pi/2} + \dots + \frac{y_n}{2} \cdot \frac{y_n \Delta x}{\pi/2},$$

where each $y_i = \sqrt{1-x_i^2}$. Justify this formula. What does each numerator $y_i \Delta x$ mean? What is the meaning of each fraction $\frac{y_i \Delta x}{\pi/2}$?

(d) Explain why you can obtain \bar{y} by calculating $(1/\pi) \int_{-1}^1 (1-x^2) dx$. Evaluate this integral, and check to see that your answer agrees with the previous value for \bar{y} .

2. Find coordinates for the centroid of the region $0 \leq y \leq 1-x^2$ shown at right. Notice that you will need to begin by finding the area of this region. Find the coordinate \bar{y} by using *both* methods of slicing. Compare your answer with the centroid of the unit semicircle.

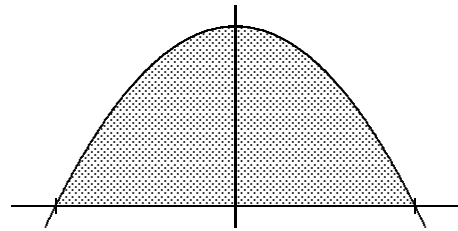

3. Use the double-angle identity $2 \cos^2 x = 1 + \cos 2x$ to help evaluate $\int_0^{2\pi} \sqrt{1 + \cos u} du$.

4. Without using your calculator, evaluate the following integrals, in terms of a :

(a) $\int_0^a \sin^2 x dx$ (b) $\int_0^a \sin^5 x \cos x dx$ (c) $\int_0^a \sin 3x \cos 3x dx$

5. Sketch the region enclosed by the graph of $y = \frac{1}{\sqrt{1+x^2}}$, the line $x = 10$, the x -axis, and the y -axis. Find the volume of the solid obtained when this region is revolved around

(a) the x -axis; (b) the y -axis.

What happens to your answers when $x = 10$ is replaced by $x = 1000$?

Mathematics 4C

1. *The hyperbolic functions.* Define $C(t) = \frac{1}{2}(e^t + e^{-t})$ and $S(t) = \frac{1}{2}(e^t - e^{-t})$, which make sense for any value of t . Calculate and simplify the expression $C(t)^2 - S(t)^2$. Notice, by the way, that $C(t)^2$ does *not* mean $C(t^2)$. Calculate and simplify the expressions $S(2t)$ and $2S(t)C(t)$. Do your answers look familiar? Can you explain the title of this paragraph?

2. Let k be a positive number. To find the area of the region \mathcal{R} enclosed by the x -axis, the line $x = 1$, and the curve $y = x^k$, Fermat devised the following ingenious approach:

(a) Choose a number u that is slightly smaller than 1, and consider the sequence of values u, u^2, u^3, u^4, \dots , which decreases geometrically to 0. As shown in the diagram, these values can be used to overlay an infinite sequence of rectangles on \mathcal{R} . Reading from the right, the area of the first rectangle is $1 - u$; what is the area of the second rectangle? what is the area of the third? Show that the sum of the rectangular areas is a *geometric series*. Find its sum, which is a function of u and k .

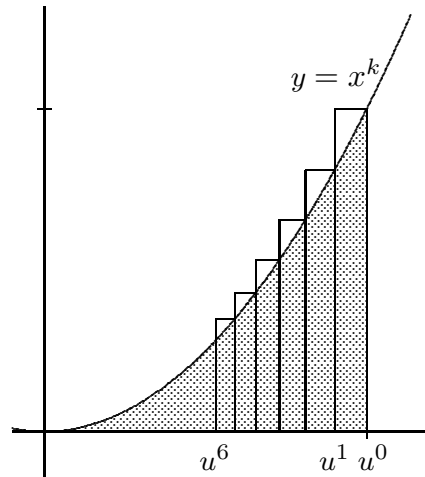

(b) This sum overestimates the area of \mathcal{R} by an amount that is smaller than the area of the first rectangle. Justify this statement.

(c) Find the limiting value of your sum as u approaches 1. It may help to consider the reciprocal of your sum formula, which should have a familiar look to it.

3. The value of a definite integral can be interpreted in many ways, depending on the application that you have in mind. For instance, the value of $\int_0^4 \sqrt{1+x^2} dx$ can be viewed as either the *area* of a hyperbolic region or the *length* of a parabolic arc. Explain how.

4. The substitution $w = \sec u$ can be applied successfully to $\int_0^x \sec^2 u \tan u du$. Show how. Then find a second substitution that also works, and reconcile your answers.

5. The circular region $(x-3)^2 + y^2 \leq 1$ is revolved around the y -axis, thereby generating a doughnut-like solid. Find the volume of this solid.

6. Define $T(t) = S(t)/C(t)$, recalling the hyperbolic definitions $C(t) = \frac{1}{2}(e^t + e^{-t})$ and $S(t) = \frac{1}{2}(e^t - e^{-t})$. Calculate, simplify, and contemplate $C'(t)$, $S'(t)$, and $T'(t)$. Do your answers look familiar?

7. A cylindrical water glass is filled with water and then tilted until the remaining water covers exactly half the bottom of the cylinder. What fractional part of the water remains?

Mathematics 4C

1. The integral $\int_0^\infty \cos x \, dx$ is improper. Show that it neither converges to a finite value nor *diverges to infinity*.

2. *The hyperbolic functions.* It is customary to define the *hyperbolic sine* function, the *hyperbolic cosine* function, and the *hyperbolic tangent* function by

$$\cosh t = \frac{e^t + e^{-t}}{2}, \quad \sinh t = \frac{e^t - e^{-t}}{2}, \quad \tanh t = \frac{e^t - e^{-t}}{e^t + e^{-t}},$$

respectively. The reciprocals of these functions are called *sech*, *csch*, and *coth*, respectively. The name “hyperbolic” is chosen because these six functions have a relationship to the *unit hyperbola* $x^2 - y^2 = 1$ that is analogous to the relationship between the six circular functions (*sin*, *cos*, *tan*, *csc*, *sec*, and *cot*) and the unit circle.

(a) Show that $\tanh t = \frac{\sinh t}{\cosh t}$.

(b) Sketch graphs of *sinh*, *cosh*, and *tanh*.

(c) Find expressions equivalent to $\cosh(-t)$ and $1 + (\sinh t)^2$. It is customary — as with the circular functions — to write powers $(\sinh t)^2$ in the form $\sinh^2 t$.

(d) Recall the addition identity $\cos(p + q) = \cos p \cos q - \sin p \sin q$ for circular functions. Show that there is an analogous identity for $\cosh(p + q)$.

(e) Find a simple expression that is equivalent to the sum $\cosh t + \sinh t$.

3. The diagram at right shows the portion of the spiral $r = 1.2^\theta$ that corresponds to $-0.2 \leq \theta \leq 1.7$. The area enclosed by this arc and the rays $\theta = 0$ and $\theta = \frac{1}{2}\pi$ can be found by integration: First cut the region into many narrow sectors (the diagram shows only twenty), each of which has a nearly constant radius. Then use an appropriate area formula for circular sectors to help you explain why the requested area is equal to the value of the definite

integral $\int_0^{\pi/2} \frac{1}{2}(1.2)^{2\theta} \, d\theta$. Evaluate the integral.

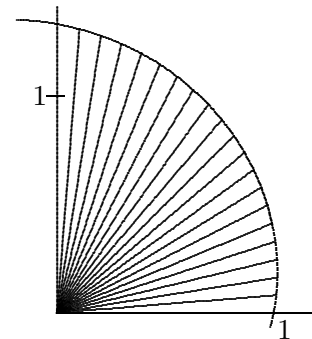

4. Verify that $\int \sin^n u \, du = -\frac{1}{n} \sin^{n-1} u \cos u + \frac{n-1}{n} \int \sin^{n-2} u \, du$, a *reduction formula* that is valid for positive n . To establish this recursive formula, you will need to use antidifferentiation by parts, as well as the Pythagorean identity $\cos^2 u = 1 - \sin^2 u$.

5. You have seen that $\sum_{n=1}^{\infty} (-1)^{n-1} \frac{1}{n} x^n = x - \frac{1}{2}x^2 + \frac{1}{3}x^3 - \dots$ is the Maclaurin series for $\ln(1+x)$. For most values of x , this formula does not represent $\ln(1+x)$, because the series does not even converge. Explain. The most interesting case is $x = 1$. Find a way to convince yourself that the series $1 - \frac{1}{2} + \frac{1}{3} - \frac{1}{4} + \frac{1}{5} - \dots$ does converge (probably to $\ln 2$).

6. Suppose that λ is a line drawn through C , the centroid of a region \mathcal{R} . Is it necessarily true that λ *bisects* the area of \mathcal{R} ? Explain your response, and illustrate with an example.

Mathematics 4C

1. When asked to evaluate $\int_{\pi/4}^{\pi/3} \tan x \, dx$, a calculus student responded “ $\frac{1}{2} \ln 2$.” When asked to evaluate $\int_{\pi/4}^{2\pi/3} \tan x \, dx$, the same student again responded “ $\frac{1}{2} \ln 2$.” Which of these two answers is correct, and why?

2. Find the centroid of the triangular region whose vertices are $(0, 0)$, $(a, 0)$, and (b, c) . This justifies the geometric use of the word “centroid” for the concurrence of medians.

3. In the following calculations, let I_n stand for the value of the definite integral $\int_0^{\pi/2} \cos^n x \, dx$, where n is a nonnegative integer.

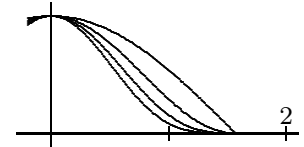

(a) Show that $I_0 = \frac{1}{2}\pi$, $I_1 = 1$, $I_2 = \frac{1}{4}\pi$, and $I_3 = \frac{2}{3}$.

(b) Notice that $I_0 > I_1 > I_2 > I_3$. Without calculating any more integrals, explain why this *monotonic* pattern continues $I_3 > I_4 > I_5 > I_6 > \dots$.

(c) Apply integration by parts to $\int_0^{\pi/2} \cos^n x \, dx$ to show that $I_n = \frac{n-1}{n} I_{n-2}$. You will need the Pythagorean identity $\sin^2 x = 1 - \cos^2 x$ to establish this recursive formula.

(d) Use the recursion to calculate $I_{10} = \frac{9}{10} \cdot \frac{7}{8} \cdot \frac{5}{6} \cdot \frac{3}{4} \cdot \frac{1}{2} \cdot \frac{\pi}{2}$ and $I_{11} = \frac{10}{11} \cdot \frac{8}{9} \cdot \frac{6}{7} \cdot \frac{4}{5} \cdot \frac{2}{3} \cdot 1$, then confirm the general formulas

$$I_{2k} = \frac{2k-1}{2k} \dots \frac{5}{6} \cdot \frac{3}{4} \cdot \frac{1}{2} \cdot \frac{\pi}{2} \quad \text{and} \quad I_{2k+1} = \frac{2k}{2k+1} \dots \frac{6}{7} \cdot \frac{4}{5} \cdot \frac{2}{3} \cdot 1$$

Notice that these integrals alternate between rational multiples of π and rational numbers. The supplementary problems show how Wallis used this feature to find a formula for π .

4. You have seen that $\int_0^\infty f(t)e^{-t} \, dt = \int_0^\infty f'(t)e^{-t} \, dt$ is true for some functions f , such as $f(t) = t^3$. Find some non-polynomial examples.

5. Without using a calculator, evaluate the following definite integrals:

(a) $\int_0^{c^2} \sin \sqrt{x} \, dx$ (b) $\int_0^u \frac{e^x - e^{-x}}{e^x + e^{-x}} \, dx$ (c) $\int_0^u \frac{e^{2x} - 1}{e^{2x} + 1} \, dx$ (d) $\int_0^{\pi/2} \frac{\cos x}{(1 + \sin x)^n} \, dx$

6. An ideal snowplow removes snow at a constant rate. In essence, this means that the speed of a plow is inversely proportional to the depth of the snow being plowed. For instance, doubling the depth of the snow would cut the speed of a plow in half. Explain this reasoning. Suppose that a plow moves forward at 900 feet per minute through snow that is one foot deep. Suppose also that a raging blizzard is accumulating a foot of snow every two hours, and that a plow begins its route when the snow is exactly six inches deep. Some questions:

- (a) What is the speed of this plow when it begins plowing?
- (b) What is the speed of this plow one hour later?
- (c) How far does this plow travel during its hour of plowing?

Mathematics 4C

1. Let \mathcal{R} be the first-quadrant region enclosed by the y -axis, the hyperbola $y = \sqrt{x^2 + 9}$, and the line $y = 5$. Find the volume of the solid that results when \mathcal{R} is revolved around the y -axis. You can check your answer by doing the problem twice — using both the cross-section method and the shell method.
2. Given a constant a , the expression $\lim_{x \rightarrow a} \frac{\sin x - \sin a}{x - a}$ is indeterminate. Explain. What is the result of applying l'Hôpital's Rule to this example?
3. When applied to the cycloid $(x, y) = (t - \sin t, 1 - \cos t)$, the integrals $\frac{1}{2\pi} \int_0^{2\pi} y \, dt$ and $\frac{1}{2\pi} \int_0^{2\pi} y \, dx$ have similar, yet different, meanings. Evaluate both of these integrals, and interpret your results. Remember that dx is replaced by $\frac{dx}{dt} dt$.
4. Let $g(x) = 13 + 7(x - 1) + \frac{19}{2}(x - 1)^2 + \frac{31}{6}(x - 1)^3 + \frac{5}{24}(x - 1)^4$. Calculate the values $g(1)$, $g'(1)$, $g''(1)$, $g'''(1)$, $g^{(4)}(1)$, and $g^{(5)}(1)$ for this curve.
5. Find an equation for the fourth-degree polynomial $p(x)$ that has the following properties: $p(1) = 1$, $p'(1) = \frac{1}{2}$, $p''(1) = -\frac{1}{4}$, $p'''(1) = \frac{3}{8}$, and $p^{(4)}(1) = -\frac{15}{16}$.
6. (Continuation) Graph both $y = p(x)$ and $y = \sqrt{x}$ on the same coordinate-axis system for $0 \leq x \leq 3$. Can you account for what you see? Compare the values of $p(2)$ and $\sqrt{2}$.
7. The diagram shows the *cardioid* described by the polar equation $r = 1 + \cos \theta$. Use integration to find the area of the region enclosed by this curve.
8. Describe precisely the location of the centroid of a solid, right circular cone.
9. Find constants a and b so that the expressions $\frac{1}{x^2 - 25}$ and $\frac{a}{x - 5} + \frac{b}{x + 5}$ are equivalent.

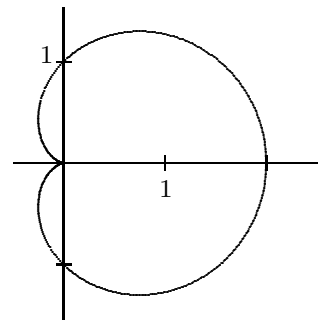

Mathematics 4C

1. Given a function f , the terms of its Maclaurin series depend on x . Thus *there is a different series of numbers to consider for each value of x* . Whether such a series converges depends on what x is. The sum of such a series — if there is one — also depends on what x is (not surprising, if you expect the sum to be $f(x)$). Consider the Maclaurin series of e^x , which is $1 + x + \frac{1}{2}x^2 + \frac{1}{6}x^3 + \frac{1}{24}x^4 \dots$, or $\sum_{n=0}^{\infty} \frac{1}{n!} x^n$. For each of the following, guess the sum of the series, then use your calculator to find a few partial sums to support your prediction: (a) $\sum_{n=0}^{\infty} \frac{1}{n!}$ (b) $\sum_{n=0}^{\infty} (-1)^n \frac{1}{n!}$ (c) $\sum_{n=0}^{\infty} \frac{1}{n!} (\ln 2)^n$

Example (b) is an example of an *alternating series*. Explain the terminology.

2. (Continuation) It is not obvious that series (a) converges. A term-by-term *comparison* with the geometric series $\sum_{n=0}^{\infty} \left(\frac{1}{2}\right)^{n-1}$ is helpful. Provide the details. What about (c)?

3. The substitution concept — also known as *changing variables* — is useful in problems that have nothing to do with integration. For example, consider the problem of finding the area of the largest rectangle that can be inscribed in the ellipse $\frac{1}{25}x^2 + \frac{1}{16}y^2 = 1$, with its sides parallel to the coordinate axes. Show that a parametric approach simplifies matters so much that derivatives are not even necessary.

4. Evaluate: (a) $\sinh(\ln 2)$ (b) $\cosh(\ln a)$

5. Solve the equations $\cosh x = 2$ and $\sinh x = 2$ for x . For what values of c is there (a) a unique value of x that solves $\cosh x = c$? (b) a unique value of x that solves $\sinh x = c$?

6. Use partial fractions to find an antiderivative for $f(x) = \frac{1}{x^2 - a^2}$. Assume that $a \neq 0$.

7. Standing near a hemispherical dome whose radius is 64 feet, Wes repeatedly tosses a ball straight up into the air and catches it. Illuminated by the horizontal rays of the setting Sun, the ball casts a moving shadow onto the dome. After t seconds of flight, the height of one of these tosses is $64t - 16t^2$ feet. For this toss, find the speed of the shadow on the dome (a) when $t = 1$; (b) when $t = 1.99$; (c) as $t \rightarrow 2$.

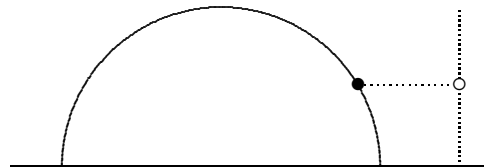

8. *Alternating Series Theorem*. Choose a sequence of positive numbers x_0, x_1, x_2, \dots that decreases monotonically to zero. The *alternating series* $\sum_{n=0}^{\infty} (-1)^n x_n$ must converge, to a sum that is smaller than x_0 , larger than $x_0 - x_1$, smaller than $x_0 - x_1 + x_2$, and so forth. Explain. How close to the sum of your series is the partial sum $\sum_{n=0}^{10} (-1)^n x_n$?

Mathematics 4C

1. The diagram shows the graph $x^3 + y^3 - 3xy = 0$. You have figured out that it is also the graph of the parametric equation $P_t = \left(\frac{3t}{1+t^3}, \frac{3t^2}{1+t^3} \right)$, defined for all t -values except -1 . Notice that t is the slope of the segment that joins $(0, 0)$ to P_t . Use these formulas to find the area enclosed by this loop.

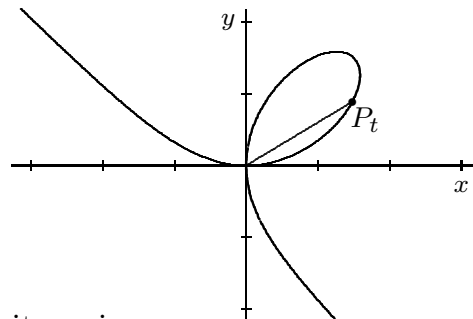

2. Given that $0.835648848\dots$ is the sum of the infinite series $\sum_{n=0}^{\infty} (-1)^n \frac{1}{3n+1}$, what can you deduce about the partial sum $\sum_{n=0}^{333332} (-1)^n \frac{1}{3n+1}$?

3. The term-by-term derivative of the Maclaurin series for a function f is itself a Maclaurin series for some function. Identify that function.

4. Evaluate $\int_6^{10} \ln x \, dx$ and $\int_6^{10} \ln(16-x) \, dx$. Could you have predicted the result?

5. Write the series $x - \frac{1}{3}x^3 + \frac{1}{5}x^5 - \frac{1}{7}x^7 + \frac{1}{9}x^9 - \dots$ using sigma notation, then show that it is the Maclaurin series for $\arctan x$. Show that this series converges, for each value of x that is between -1 and 1 , inclusive. Of particular interest is *Gregory's series* $1 - \frac{1}{3} + \frac{1}{5} - \frac{1}{7} + \frac{1}{9} - \dots$, corresponding to $x = 1$. What is the sum of Gregory's series? Why do you think so?

6. For what values of p is the improper integral $\int_1^{\infty} \frac{1}{x^p} \, dx$ convergent?

7. For what values of p is the integral $\int_0^1 \frac{1}{x^p} \, dx$ improper? For what values of p is the integral both improper and convergent?

8. Your calculator might report a faulty answer if you ask it to evaluate $\int_0^1 x^{-0.9999} \, dx$, despite the fact that this improper integral is convergent. Why?

9. Find the centroid of the region enclosed by the isosceles trapezoid whose vertices are $(0, 0)$, $(9, 0)$, $(6, 6)$, and $(3, 6)$.

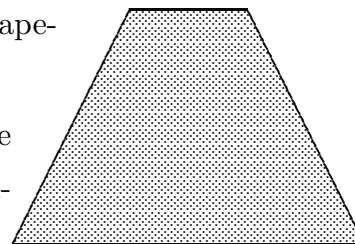

10. By making an appropriate trigonometric substitution, solve the antiderivative problem $\int \frac{1}{x^2\sqrt{x^2+1}} \, dx$. Express your answer as a function of x .

Mathematics 4C

1. Because $\ln x$ is defined only for positive values of x , there can be no Maclaurin series for $\ln x$. The derivative-matching concept can be applied to *any* point on the graph of a differentiable function, however. Choosing the point $x = 1$ leads to a *Taylor series*

$$(x - 1) - \frac{1}{2}(x - 1)^2 + \frac{1}{3}(x - 1)^3 - \dots = \sum_{n=1}^{\infty} (-1)^{n+1} \frac{1}{n} (x - 1)^n$$

for $\ln x$. Explain where the coefficients of this series come from. For what values of x do you think that this series is convergent? Graph $y = \ln x$ and its *third-degree Taylor polynomial* $y = (x - 1) - \frac{1}{2}(x - 1)^2 + \frac{1}{3}(x - 1)^3$ on the same system of coordinate axes. What attributes do these curves have in common?

2. (Continuation) Replace x by 0 in the Taylor series for $\ln x$. Because $\ln x$ approaches $-\infty$ as x approaches 0, it seems likely that the series $-1 - \frac{1}{2} - \frac{1}{3} - \frac{1}{4} - \dots = -\sum_{n=1}^{\infty} 1/n$ diverges to $-\infty$. In other words, the series $\sum_{n=1}^{\infty} 1/n$ probably diverges to ∞ . One way to prove this is to notice that the third and fourth terms sum to more than $\frac{1}{2}$, as do the fifth, sixth, seventh, and eighth terms. Finish this *comparison* argument. The series $\sum_{n=1}^{\infty} 1/n$ is known as the *harmonic series*.

3. Show how to evaluate $\int_0^{\pi} e^x \cos x \, dx$ by using two applications of integration by parts.

4. A *geometric sequence* is a list of the form a, ar, ar^2, ar^3, \dots , in which each term (except the first) is obtained by multiplying its predecessor by a fixed number r . In the same vein, a *geometric series* is an addition problem formed by taking consecutive terms from some geometric sequence. An example: $16 + 24 + 36 + 54$ is a four-term geometric series whose sum is 130. Another example: $32 - 16 + 8 - 4 + \dots + 0.125$ is a nine-term geometric series whose sum is 21.375. It is convenient to have a concise formula for sums of this type.

(a) Given an equation $x = a + ar + ar^2 + ar^3 + ar^4 + \dots + ar^n$, multiply both sides by r to obtain a new equation. Subtract one equation from the other to obtain a useful formula. It should be apparent from your formula that the sum of a geometric series can be found quickly, once three things are known: the first term, the last term, and the multiplier. Explain.

(b) Find the sum of the geometric series $\sum_{k=0}^{20} 3000(1.05)^k$ and $\sum_{n=0}^{50} 18\left(-\frac{2}{3}\right)^n$.

5. Consider the first-quadrant region \mathcal{R} enclosed by the curves $y = x^2$ and $y = \sqrt{x}$.

(a) Find the area of \mathcal{R} .

(b) Find the volume of the solid that is obtained when \mathcal{R} is revolved around the x -axis. Check your answer by redoing the problem using a different method.

(c) The centroid of \mathcal{R} is (of course) somewhere on the line $y = x$. Where?

Mathematics 4C

1. A speckled red superball has an 80% rebound ratio. When it is dropped from a height of 25 feet, it bounces and bounces and bounces . . .
 - (a) How high does the ball bounce after it strikes the ground for the third time?
 - (b) How high does the ball bounce after it strikes the ground for the nineteenth time?
 - (c) When it strikes the ground for the second time, the ball has traveled 45 feet in a *downward* direction. Verify this. How far downwards has the ball traveled when it strikes the ground for the nineteenth time?
 - (d) At the top of its second rebound, the ball has traveled 36 feet in an *upward* direction. At the top of its nineteenth rebound, how far upwards has the ball traveled?
 - (e) At the top of its nineteenth rebound, how far has the ball traveled in total?
 - (f) How far would the ball travel if we just let it bounce and bounce and bounce . . . ?

2. Show that $\lim_{x \rightarrow \infty} \frac{1}{x} (\ln x)^{20}$ is zero. Show that in fact $\lim_{x \rightarrow \infty} \frac{1}{x} (\ln x)^p$ is zero for *any* exponent p , including the examples $p = 2002$, $p = -6$, and $p = 7.35$.

3. Consider the region \mathcal{R} enclosed by the line $y = x + 3$ and the parabola $y = 5 - x^2$. Find the volume of the three-dimensional solid obtained by revolving \mathcal{R}
 - (a) around the x -axis; (b) around the line $x = 2$.

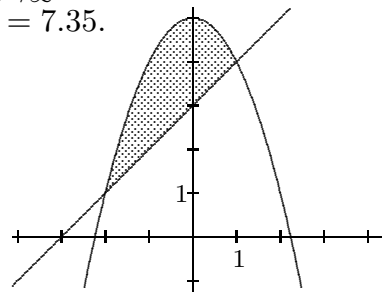

4. Because $g(x) = \sqrt{x}$ is not differentiable at $x = 0$, it is impossible to find a Maclaurin series for g . It is possible to write g in powers of $x - 1$, however. Find the third-degree Taylor approximation for $g(x)$ in powers of $x - 1$.

5. Another indeterminate form that is often encountered in Calculus is 1^∞ . The best-known example is the familiar definition $e = \lim_{x \rightarrow \infty} \left(1 + \frac{1}{x}\right)^x$. Show that 1^∞ is truly an ambiguous expression by finding another expression of this type that has a different value. Exponential equations are often dealt with by applying logarithms — for example, the equation $y = \left(1 + \frac{1}{x}\right)^x$ is equivalent to $\ln y = x \ln \left(1 + \frac{1}{x}\right)$. Show that this logarithmic technique allows l'Hôpital's Rule to be used in evaluating $\lim_{x \rightarrow \infty} \left(1 + \frac{2}{x}\right)^x$.

6. The graph of the *limaçon* $r = 1 + 2 \cos \theta$ is shown at right. Find the shaded area enclosed by the small loop in the graph.

7. It is not necessary to evaluate either integral in order to predict that $\int_0^{\pi/2} \frac{\sin x}{2 - \sin x} dx$ and $\int_0^{\pi/2} \frac{\cos x}{2 - \cos x} dx$ will have the same value. Explain the reasoning behind this statement.

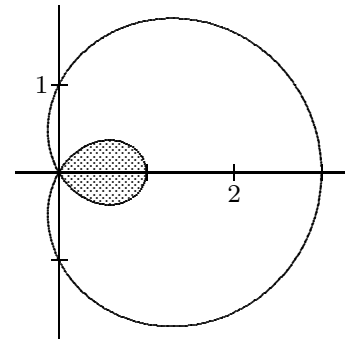

Mathematics 4C

1. Assume that an ideal snowplow removes snow at a constant rate, which means essentially that the speed of the plow is inversely proportional to the depth of the snow being plowed. During a recent storm it snowed steadily, starting at 11 a.m. An ideal plow began to clear a road at noon, taking 30 minutes to clear the first mile. At what time did the plow finish clearing the second mile?

2. Calculate the precise location of the centroid of a homogeneous solid hemisphere, whose radius is r .

3. The repeating decimal $0.12121212 \dots$ can be thought of as an infinite geometric series. Write it in the form $a + ar + ar^2 + ar^3 + \dots$, and also express it using sigma notation. By summing the series, find the rational number that is equivalent to this repeating decimal.

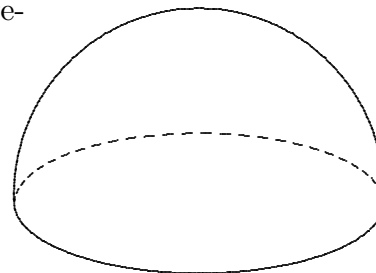

4. It is evident that Rolle's Theorem is a special case of the Mean-Value Theorem. Show, conversely, that the Mean-Value Theorem is a consequence of Rolle's Theorem.

5. *The Gap Theorem.* Given that f and g be differentiable functions on the interval $[a, b]$, and that $f(a) = g(a)$ and $f(b) = g(b)$, it follows from the Mean-Value Theorem that $f'(c) = g'(c)$ for some c in the interval (a, b) . Explain the reasoning.

6. The cycloid $(x, y) = (t - \sin t, 1 - \cos t)$ is the path followed by a point on the edge of a wheel of unit radius that is rolling along the x -axis. The point begins its journey at the origin (when $t = 0$), and returns to the x -axis at $x = 2\pi$ (when $t = 2\pi$), after the wheel has made one complete turn. What is the length of the cycloidal path that joins these x -intercepts?

7. Find the Maclaurin series for $f(x) = \frac{1}{(1-2x)(1-3x)}$ by using partial-fraction technique. Then check your answer by multiplying together two (geometric) Maclaurin series.

8. A fact from physics: The time needed to fall from a height of h feet (or to rise to that height after a bounce) is $\frac{1}{4}\sqrt{h}$ seconds. Now suppose that a ball, whose rebound ratio is 64 percent, is dropped from a height of 16 feet. How much time passes before the ball strikes the ground for the sixth time? How far has the ball traveled by then? How far does the ball travel if it is left to bounce "forever"? How much time does all this bouncing take?

9. Choose trigonometric substitutions to evaluate $\int_0^{1/2} \frac{x^3}{\sqrt{1-x^2}} dx$ and $\int_0^6 \frac{1}{4+x^2} dx$.

10. A series $\sum_{n=1}^{\infty} a_n$ is said to *converge* if its partial sums approach a limit, which is called the *sum* of the series. Consider the example $\frac{1}{2} + \frac{1}{6} + \frac{1}{12} + \dots$, for which $a_n = \frac{1}{n^2 + n}$ is the general term. Show that this is a convergent series.

Mathematics 4C

1. The equation $y = b^p$ produces the familiar differentiation formulas

$$\frac{dy}{dx} = pb^{p-1} \frac{db}{dx} \quad \text{and} \quad \frac{dy}{dx} = b^p \ln b \frac{dp}{dx}$$

when p does not depend on x and when b does not depend on x , respectively.

- (a) Verify that each of these formulas is correct.
 (b) Find a differentiation formula that applies when both the exponent p and the base b depend on x . It helps to begin by applying logarithms to both sides of $y = b^p$.
 (c) Use your formula to find $\frac{dy}{dx}$ when $y = (\sin x)^x$.

2. Let $f(x) = \sin x$ and $g(x) = 1 - \cos x$, whose graphs intersect at $x = 0$ and $x = \frac{1}{2}\pi$. There is a c between 0 and $\frac{1}{2}\pi$ for which $f'(c) = g'(c)$. Calculate c . Illustrate this result using a careful sketch of the graphs for $0 \leq x \leq \frac{1}{2}\pi$.

3. Find the area of the first-quadrant region enclosed by the x -axis, the line $x = \frac{5}{3}$, and the hyperbola $x^2 - y^2 = 1$. It helps to notice that $\frac{5}{3} = \cosh(\ln 3)$, which should suggest an effective substitution to apply to your area integral.

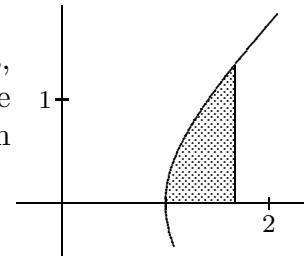

4. Evaluate without a calculator:

(a) $\int_1^{14} \frac{x}{\sqrt[3]{2x-1}} dx$ (b) $\int_0^{\pi/2} \sin^{99} x dx$ (c) $\int_0^{\ln 5} \frac{e^x}{5+e^x} dx$

5. Suppose that f and g are twice-differentiable functions for $a \leq x \leq b$. Given that $f(a) = g(a)$, $f'(a) = g'(a)$, and $f(b) = g(b)$, show that $f''(c) = g''(c)$ for some c strictly between a and b . (*Hint*: First show that $f'(k) = g'(k)$ for some k , where $a < k < b$.)

6. Let $f(x) = \sin x$ and $g(x) = \frac{1}{2} \sin 2x$, whose graphs intersect at $x = 0$ and $x = \pi$, the first intersection being tangential.

- (a) Verify that the intersection at $x = 0$ is tangential.
 (b) There is a c strictly between 0 and π for which $f''(c) = g''(c)$. Calculate c .

7. Suppose that f and g are thrice-differentiable functions for $a \leq x \leq b$. Given that $f(a) = g(a)$, $f'(a) = g'(a)$, $f''(a) = g''(a)$, and $f(b) = g(b)$, show that $f'''(c) = g'''(c)$ for some c strictly between a and b .

8. Write a clear statement that generalizes the preceding.

9. Find an explicit formula for the function that is inverse to $f(x) = \ln(x + \sqrt{x^2 + 1})$.

10. Calculate the following:

(a) $\frac{d}{dx} \arcsin \sqrt{x}$ (b) $\frac{d}{dx} \arcsin(\tanh x)$ (c) $\int_0^1 \frac{\sinh t}{\cosh^5 t} dt$ (d) $\int_0^{\ln 2} \tanh t dt$

Mathematics 4C

1. Let $f(x) = \cos x$, whose second Maclaurin polynomial is $p_2(x) = 1 - \frac{1}{2}x^2$.
- (a) The graphs of f and p_2 intersect when $x = 0$, but do not intersect when $x = \pi$. Confirm by making a sketch.
- (b) Show that there is a unique value of K for which the graph of $g(x) = p_2(x) + Kx^3$ intersects the graph of f at $(\pi, -1)$. Calculate this K , which is a small positive number.
- (c) After you confirm that $f(0) = g(0)$, $f'(0) = g'(0)$, and $f''(0) = g''(0)$, explain why it follows that $f'''(c) = g'''(c) = 6K$ for some c between 0 and π .
- (d) Conclude that $f(\pi) = p_2(\pi) + \frac{1}{6}f'''(c)\pi^3$ for some c between 0 and π .

2. From the 1988 AP: Suppose that f is a differentiable function, whose average value on any interval $0 \leq x \leq b$ is $\frac{1}{2}(f(0) + f(b))$. Suppose also that $f(0) = 5$ and $f(3) = -1$.
- (a) Find $\int_0^3 f(x) dx$.
- (b) Show that $f(x) = 5 + xf'(x)$ is true for all positive values of x .
- (c) Use part (b) to find $f(x)$.

3. Find the length of the curve $y = \cosh x$ that joins the points $(0, 1)$ and $P_a = (a, \cosh a)$. This curve is called a *catenary*.

4. Another way to show the divergence of the harmonic series is to compare the series to an integral. For example, explain why

$$1 + \frac{1}{2} + \frac{1}{3} + \cdots + \frac{1}{10000} \text{ is greater than } \int_1^{10001} \frac{1}{x} dx$$

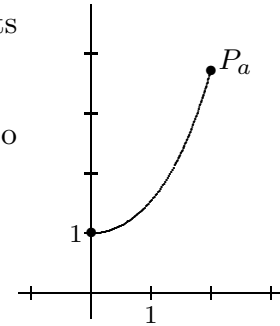

without evaluating either the sum or the integral. Then use this idea to complete a proof that the harmonic series diverges.

5. (Continuation) Show that the series $\sum_{n=1}^{\infty} \frac{1}{n^2}$ converges, and that its sum is less than 2.

6. *The Extended Mean-Value Theorem.* Suppose that f is a function that is $n + 1$ times differentiable for $0 \leq x \leq b$, and let p_n be the n^{th} Maclaurin polynomial of f . Define $g(x) = p_n(x) + Kx^{n+1}$, where the constant K is chosen to make $f(b) = g(b)$.

- (a) Show that K is unique by writing a formula for it.
- (b) Explain why $f(0) = g(0)$, $f'(0) = g'(0)$, \dots , and $f^{(n)}(0) = g^{(n)}(0)$.
- (c) Show that $f^{(n+1)}(c) = g^{(n+1)}(c)$ for some c strictly between 0 and b . Conclude that

$$f(b) = f(0) + f'(0)b + \frac{1}{2}f''(0)b^2 + \cdots + \frac{1}{n!}f^{(n)}(0)b^n + \frac{1}{(n+1)!}f^{(n+1)}(c)b^{n+1}$$

holds for some c strictly between 0 and b .

7. (Continuation) Illustrate this theorem using two examples:

- (a) $f(x) = e^x$, $n = 2$, and $b = 4$
- (b) $f(x) = e^x$, $n = 3$, and $b = 4$

Notice that the location of c depends on both n and b .

- (c) Prove that the Maclaurin series for $f(x) = e^x$ converges to e^x when $x = 4$.

Mathematics 4C

1. The statement of the Extended Mean-Value Theorem can be written so that it applies to any Taylor series, not just to a Maclaurin series. This general version is the work of Lagrange. Write a careful statement of it.

(a) Use the function defined by $f(x) = \ln x$ to illustrate this version of the Extended Mean-Value Theorem. Let $b = 2$ and $n = 3$, and base your calculations at $(a, f(a)) = (1, 0)$.

(b) Using this theorem, $\ln x$ can be expressed as a series of powers of $x - 1$, namely

$$\ln x = (x - 1) - \frac{1}{2}(x - 1)^2 + \frac{1}{3}(x - 1)^3 - \dots = \sum_{n=1}^{\infty} (-1)^{n-1} \frac{1}{n} (x - 1)^n,$$

for certain values of x . Show that the series converges to $\ln x$ for $\frac{1}{2} \leq x \leq 2$.

2. Find the area of the first-quadrant region enclosed by the x -axis, the line $x = \cosh k$, and the hyperbola $x^2 - y^2 = 1$. Your answer will be expressed in terms of the number k , of course. Then use your answer to write a formula for the area of the shaded region at right. The coordinates of point P are $(\cosh k, \sinh k)$. You may be surprised by the simplicity of your answer. Notice how it reinforces the analogy between circular and hyperbolic functions.

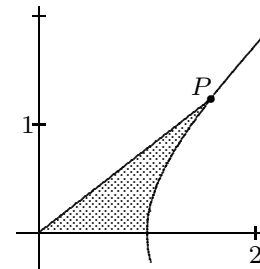

3. *The Integral Test.* Assume that $f(x)$ is positive and decreasing for positive x , and that $\lim_{x \rightarrow \infty} f(x) = 0$. Consider the two convergence questions: Does $\int_1^{\infty} f(x) dx$ have a finite value? Does the infinite series $f(1) + f(2) + f(3) + \dots$ have a finite sum? You have considered the example $f(x) = 1/x$, for which both questions had the same answer (no), and also the example $f(x) = 1/x^2$, for which both questions had the same answer (yes). *This is always the case — both questions have the same answer.* Explain why. The diagrams below may be of some help.

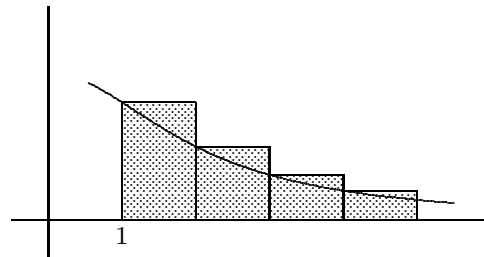
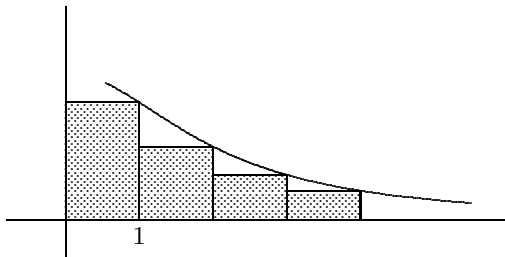

4. Verify that the fraction $\frac{1}{n^2 + n}$ is equivalent to $\frac{1}{n} - \frac{1}{n + 1}$. This *partial-fraction decomposition* enables an easy evaluation of the integral $\int_1^{\infty} \frac{1}{x^2 + x} dx$ and the sum $\sum_{n=1}^{\infty} \frac{1}{n^2 + n}$. You could have anticipated that the integral would have a smaller value than the sum. Explain how.

5. Use the Extended Mean-Value Theorem to show that the Maclaurin series for $\sin x$ converges to $\sin x$ for every value of x .

Mathematics 4C

1. Find coordinates for the centroid of the circular sector formed by the unit circle, the y -axis, and the line $y = x$.

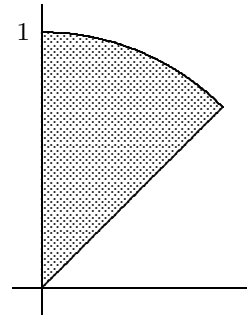

2. Because the series $\frac{1}{2} + \frac{8}{4} + \frac{27}{8} + \cdots = \sum_{n=1}^{\infty} n^3 \left(\frac{1}{2}\right)^n$ is not geometric, it is difficult to decide whether it converges to a finite sum. The following exercises introduce a comparison approach to the convergence of positive series. Use the abbreviation $y_n = n^3 \left(\frac{1}{2}\right)^n$.

(a) Calculate a formula for the ratio $\frac{y_n}{y_{n-1}}$ of a typical term to its predecessor. Show that this ratio is greater than 1 when $2 \leq n \leq 4$, but less than 1 when $5 \leq n$.

(b) Notice that the ratio $\frac{y_n}{y_{n-1}}$ is actually less than 0.98 whenever $5 \leq n$, and that $y_4 = 4$. Deduce that $y_n \leq 4(0.98)^{n-4}$ whenever $4 \leq n$, and that $0 = \lim_{n \rightarrow \infty} y_n$.

(c) Explain why $4 + 4(0.98) + 4(0.98)^2 + \cdots = 200$.

(d) Conclude that $\sum_{n=1}^{\infty} n^3 \left(\frac{1}{2}\right)^n < \frac{47}{8} + 200$.

3. (Continuation) The overestimate $\sum_{n=1}^{\infty} n^3 \left(\frac{1}{2}\right)^n < 205.875$ can be improved considerably.

First notice that $\frac{y_n}{y_{n-1}}$ is less than 0.8 whenever $7 \leq n$. Use this information, together with the first six terms of the series, to conclude that $\sum_{n=1}^{\infty} n^3 \left(\frac{1}{2}\right)^n < 30.66$.

4. (Continuation) Does the ratio $\frac{y_n}{y_{n-1}}$ ever become smaller than 0.51?

5. Given that p and q are positive numbers whose sum is 1, find the sum of the infinite series $q + pq + p^2q + p^3q + \cdots$. Interpret your answer in the context of probability.

6. Use the Maclaurin series for e^x and e^{-x} to help you find the Maclaurin series for $\sinh x$, $\cosh x$, and e^{-x^2} . Write your answers using sigma notation. For what values of x do these series converge?

7. If $0 = \lim_{n \rightarrow \infty} a_n$, is it necessarily true that $\sum_{n=1}^{\infty} a_n$ converges?

8. Find the exact sum of the series (a) $\sum_{n=0}^{\infty} (-1)^n \frac{\pi^{2n+1}}{(2n+1)!}$ (b) $\sum_{n=0}^{\infty} \left(\frac{x-2}{3}\right)^n$

Mathematics 4C

1. The graph $y = \sec x - \tan x$ seems to cross the x -axis between $x = 0$ and $x = \pi$. Explain first why this is only an *apparent* crossing. (You will need to convert the indeterminate form $\infty - \infty$ into the form $\frac{0}{0}$ if you wish to use l'Hôpital's Rule.) Next find the apparent slope of this apparent crossing. Justify your answer, using more than just calculator data.

2. A superball is dropped from a height of h feet, and left to bounce forever. The rebound ratio of the ball is r . In terms of r and h , find formulas for

(a) the total distance traveled by the ball;

(b) the total time needed for all this bouncing to take place.

3. Apply an appropriate trigonometric substitution to evaluate $\int_{-2}^2 \frac{x^2}{(9-x^2)^{3/2}} dx$.

4. Given an arc, its centroid is — roughly speaking — the average of the points on the arc. For example, consider the semicircular arc $y = \sqrt{1-x^2}$ for $-1 \leq x \leq 1$. The centroid is usually denoted by coordinates (\bar{x}, \bar{y}) . The y -axis symmetry of this example makes it clear that $\bar{x} = 0$, thus only \bar{y} needs to be calculated. As usual, it is convenient to approximate the arc by a series of inscribed segments, whose lengths are $\sqrt{\Delta x_i^2 + \Delta y_i^2}$. Imagine that M points have been distributed uniformly along all of these segments. The task confronting you is to add all of their y -coordinates and then divide by M .

(a) For any one of these segments, it is reasonable to use the *same* y -value for every point found on the segment. What y -value would you use, and why is it reasonable?

(b) If y_i represents a segment whose length is $\sqrt{\Delta x_i^2 + \Delta y_i^2}$, then this segment has about $\frac{\sqrt{\Delta x_i^2 + \Delta y_i^2}}{\pi} M$ of the points, and it therefore contributes $y_i \frac{\sqrt{\Delta x_i^2 + \Delta y_i^2}}{\pi} M$ to the sum of all the y -coordinates. Explain this reasoning.

(c) The average of the y -coordinates of all the points on these segments is approximately

$$y_1 \frac{\sqrt{\Delta x_1^2 + \Delta y_1^2}}{\pi} + y_2 \frac{\sqrt{\Delta x_2^2 + \Delta y_2^2}}{\pi} + y_3 \frac{\sqrt{\Delta x_3^2 + \Delta y_3^2}}{\pi} + \cdots + y_n \frac{\sqrt{\Delta x_n^2 + \Delta y_n^2}}{\pi},$$

which approaches $\frac{1}{\pi} \int_{-1}^1 y \sqrt{1 + (dy/dx)^2} dx$ as the number of segments grows. Explain these remarks, then complete the calculation of \bar{y} .

5. The series $1 + 2r + 3r^2 + 4r^3 + \cdots = \sum_{n=1}^{\infty} nr^{n-1}$ is not geometric, so you do not have a formula for its sum. Apply the geometric-series trick anyway: Multiply r times both sides of $x = 1 + 2r + 3r^2 + 4r^3 + \cdots$, subtract one equation from the other, and look. Hmm...

6. Without using your calculator, find the following antiderivatives:

(a) $\int_0^x \frac{u}{\sqrt{1-u}} du$ (b) $\int_0^x \tan^4 u \sec^2 u du$ (c) $\int_0^x \frac{1}{\sqrt{9-u^2}} du$

7. Consider the region \mathcal{R} that is enclosed by the cycloid $(x, y) = (t - \sin t, 1 - \cos t)$ and the x -axis segment $0 \leq x \leq 2\pi$. When \mathcal{R} is revolved around the x -axis, the resulting solid is shaped like a *rugby* ball. Find its volume.

Mathematics 4C

1. Use the Integral Test to determine the convergence or divergence of each of the following series. For convergent examples, do not worry about finding the actual sum.

(a) $\sum_{n=1}^{\infty} \frac{1}{\sqrt{n}}$ (b) $\sum_{n=1}^{\infty} \frac{1}{n^{1.001}}$ (c) $\sum_{n=1}^{\infty} \frac{1}{n^p}$ (d) $\sum_{n=1}^{\infty} \frac{1}{p^n}$ (e) $\sum_{n=2}^{\infty} \frac{1}{n \ln n}$ (f) $\sum_{n=2}^{\infty} \frac{1}{n(\ln n)^2}$

2. Apply the partial-fraction method to $\int_4^5 \frac{1}{x^2 - 9} dx$. First factor the denominator.

3. To find the length of a polar curve $r = f(\theta)$, the diagram at right is helpful. Place the labels r , $\Delta\theta$, $r\Delta\theta$, and Δr where they belong in the diagram, then deduce an approximation formula for the length of arc PQ . Convince yourself that the accuracy of this approximation improves as $\Delta\theta$ becomes very small. Then do an example: Show that the length of the cardioid $r = 1 + \cos\theta$ is given by the definite integral $\int_0^{2\pi} \sqrt{(1 + \cos\theta)^2 + (-\sin\theta)^2} d\theta$. Now finish the job by evaluating the integral.

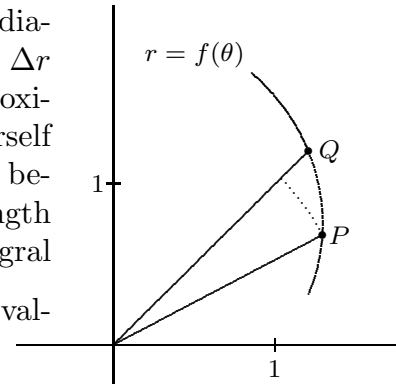

4. Evaluate: (a) $\int_0^{\pi/2} \sin^{100} x dx$ (b) $\int_0^{\infty} x^{100} e^{-x} dx$ (c) $\int_0^1 (1 - x^2)^{100} dx$

5. The centroid of the parabolic arc $y = 1 - x^2$ for $-1 \leq x \leq 1$ should be close to the centroid of the semicircular arc $y = \sqrt{1 - x^2}$ for $-1 \leq x \leq 1$. Explain, predicting which is higher. Then calculate the parabolic centroid. Use your calculator to evaluate the necessary integrals.

6. Why does the Integral Test provide no information about the series $\sum_{n=1}^{\infty} \frac{\sin n}{n}$?

7. Find a simple way to calculate the Maclaurin series for $f(x) = \sin^2 x$.

8. Let $a_n = \frac{n}{2^n}$. In a limiting sense, each term of the sequence a_1, a_2, a_3, \dots is approximately half of the preceding term. Explain. In fact, show that $0.5 < \frac{a_n}{a_{n-1}} < 0.5001$ for all suitably large values of n . How large is “suitably large”? What does this information tell you about the series $\sum_{n=1}^{\infty} a_n$?

9. Show that $\ln(n+1) < 1 + \frac{1}{2} + \frac{1}{3} + \frac{1}{4} + \dots + \frac{1}{n} < 1 + \ln n$ is true for any integer $1 < n$.

10. *Tails.* A tail of an infinite series $\sum_{n=0}^{\infty} x_n$ is the series $x_k + x_{k+1} + x_{k+2} + \dots$ obtained by removing a partial sum. If $\sum_{n=0}^{\infty} x_n$ converges, then each of its tails converges. Conversely, $\sum_{n=0}^{\infty} x_n$ must converge if one of its tails does. Discuss. Notice also that the sum of a convergent tail $\sum_{n=k}^{\infty} x_n$ can be made arbitrarily small by making k large enough.

Mathematics 4C

1. By examining ratios of successive terms, show that $\frac{10^n}{n!}$ approaches zero as n approaches infinity. Then show that the series $\sum_{n=0}^{\infty} \frac{10^n}{n!}$ converges. What is the sum of the series? Is this an example that can be analyzed by using the Integral Test?
2. *The Ratio Test.* Suppose that $\sum_{n=1}^{\infty} a_n$ is a series of positive terms, whose ratios $\frac{a_{n+1}}{a_n}$ approach a limiting value L as n approaches infinity. If $L < 1$, you can be sure that the series is convergent. Explain why.
3. (Continuation) If $L > 1$, you can be sure that the series diverges. Why?
4. (Continuation) If $L = 1$, then nothing can be said with certainty about the convergence of $\sum_{n=1}^{\infty} a_n$. Show this by finding two specific examples — one that converges and the other that diverges — both of which make $L = 1$. This is the ambiguous case.
5. Find the lengths of the following polar graphs:
(a) $r = 6 \cos \theta$ for $0 \leq \theta \leq \pi$ (b) $r = 3 \sec \theta$ for $-\frac{\pi}{3} \leq \theta \leq \frac{\pi}{3}$ (c) $r = 1.2^\theta$ for $0 \leq \theta \leq \frac{\pi}{2}$
6. Solve the antiderivative problem $\int_0^x \sec^3 u \, du$.
7. Apply the Ratio Test to show that $\sum_{n=1}^{\infty} \frac{(0.75)^n}{n}$ converges but that $\sum_{n=1}^{\infty} \frac{(1.25)^n}{n}$ diverges.
In general, for what nonnegative values of b does $\sum_{n=1}^{\infty} \frac{b^n}{n}$ converge?
8. Consider the Taylor series based at $x = 1$ for $\ln x$. Although the series consists exclusively of negative terms whenever $0 < x \leq 1$, the Ratio Test *can* be applied. Explain. Show that the series converges whenever $0 < x \leq 1$. Unlike the Extended Mean-Value Theorem, the Ratio Test does *not* tell you that the sum of the Taylor series is $\ln x$.
9. If $\sum_{n=1}^{\infty} b_n$ converges and $0 \leq a_n \leq b_n$ for all positive n , then $\sum_{n=1}^{\infty} a_n$ converges. Use the partial-sum concept to explain why this is true.
10. A definite integral that arises frequently in statistical work is $\int_0^1 e^{-x^2} dx$. Because it is impossible to evaluate this integral exactly by means of antidifferentiation, an approximation method is needed. One approach is to integrate the rapidly converging Maclaurin series for e^{-x^2} . Carry out this plan, and include enough terms to guarantee three-place accuracy, which means keeping the error smaller than $\frac{1}{2000}$. Compare your answer with the result of a numerical integration on your calculator.

Mathematics 4C

1. By now you have probably noticed the main difficulty of trying to work with non-geometric series — *there is no longer a formula for partial sums*. Finding the sum of the first hundred terms of a series can usually be done only by adding up those hundred numbers! Without a way of detecting patterns in the behavior of partial sums, it is difficult to sum most series. There are *some* interesting special cases, however. For example,

consider the series $\frac{1}{3} + \frac{1}{15} + \frac{1}{35} + \frac{1}{63} + \dots = \sum_{n=1}^{\infty} \frac{1}{4n^2 - 1}$. Confirm first that this is *not*

geometric. Then notice that there is a pattern in the partial sums. By examining the first few, you should be able to predict a value for the *thousandth* partial sum (the sum of the first thousand terms) without actually calculating it. (Perhaps you see why this is called a *telescoping* series.) It is a simple matter to find the “sum” of this series, which means to calculate the limit of the partial sums.

2. During a recent baseball game, Jace hit a long fly ball, which fell deep in the outfield for an extra-base hit. The position of the ball was $(x, y) = (70t, 96t - 16t^2)$ after t seconds of flight, where x and y are measured in feet. Home plate is at the origin $(0, 0)$, of course.

- When the ball landed, how far was it from home plate, and how fast was it moving?
- What was the greatest height attained by the ball?
- While the ball was in the air, how far did it travel along its trajectory?
- While the ball was in the air, what was its slowest speed?
- What was the average speed of the ball while it was in the air?
- When the ball was hit, Atiba was behind the backstop, standing 80 feet from home plate, in the same vertical plane as the ball’s trajectory. From Atiba’s point of view, Jace’s hit *seemed* to rise for a short time before beginning its descent to the ground. For how much time did Jace’s hit seem to Atiba to be rising?

3. Integrals such as $\int_{-1}^1 \frac{1}{x^{1/3}} dx$ and $\int_0^{\infty} \frac{1}{(1+x)\sqrt{x}} dx$ are *doubly* improper, because *two* limits are needed to resolve the convergence question. By evaluating the indicated limits, verify that both integrals converge:

(a) The first is the sum of $\lim_{c \rightarrow 0^-} \int_{-1}^c \frac{1}{x^{1/3}} dx$ and $\lim_{p \rightarrow 0^+} \int_p^1 \frac{1}{x^{1/3}} dx$.

(b) The second is the sum of $\lim_{p \rightarrow 0^+} \int_p^4 \frac{1}{(1+x)\sqrt{x}} dx$ and $\lim_{k \rightarrow \infty} \int_4^k \frac{1}{(1+x)\sqrt{x}} dx$.

4. It is tempting to think that $\int_{-1}^1 \frac{1}{x} dx = 0$ and that $\int_{-\infty}^{\infty} \sin x dx = 0$. In fact, neither of these improper integrals is convergent. Explain why.

5. Given a polar curve $r = f(\theta)$, it can be represented parametrically using the equations $x = f(\theta) \cos \theta$ and $y = f(\theta) \sin \theta$. Show that the expression $\sqrt{\left(\frac{dx}{d\theta}\right)^2 + \left(\frac{dy}{d\theta}\right)^2}$ can be simplified to a familiar form.

Mathematics 4C

1. Let $y = \sqrt[3]{x}$. Find the first three nonzero terms of the Taylor series for f that is written in powers of $x - 8$, and use these terms to find an approximate value for $\sqrt[3]{8.4}$.

2. Find antiderivatives: (a) $\int_0^x \sec^4 u \tan^2 u \, du$ (b) $\int_2^x \frac{1}{\sqrt{u^2 - 1}} \, du$

3. If $\sum_{n=1}^{\infty} a_n$ diverges and $0 \leq a_n \leq b_n$ holds for all positive n , then $\sum_{n=1}^{\infty} b_n$ diverges. Why?

4. (Continuation) By means of an example, show that the statement would not be true if the hypothesis $0 \leq a_n \leq b_n$ were replaced by the simpler hypothesis $a_n \leq b_n$.

5. Find the area enclosed by both loops of the *lemniscate* shown at right. It is described by the polar equation $r^2 = \cos 2\theta$. To put the correct limits on your integral, you will need to notice that the curve is undefined for some values of θ , while for other values of θ there are two values of r .

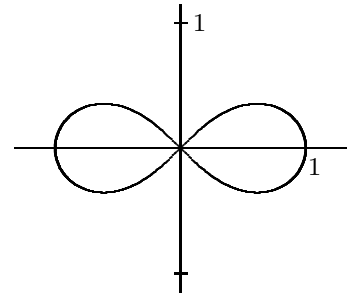

6. Find coordinates for the centroid of the cycloidal arc defined by $(x, y) = (t - \sin t, 1 - \cos t)$ for $0 \leq t \leq 2\pi$.

7. When a wheel rolls along at fifty miles per hour, there is always a point on its rim that is moving at one hundred miles per hour, and another point on its rim that is stationary. Make calculations that explain this strange statement.

8. (Continuation) When an automobile tire is discarded after being driven 40000 miles, it is a fact that most of the tire has traveled *more* than 40000 miles — some parts of the tire have traveled nearly 51000 miles! Make calculations that explain this strange statement.

9. *The triangle inequality and series.* Explain why $|a_1 + a_2| \leq |a_1| + |a_2|$. Notice that this is an interesting question only if a_1 and a_2 differ in sign. Next, justify the inequality $|a_1 + a_2 + a_3| \leq |a_1| + |a_2| + |a_3|$. Finally, write and prove a generalization that applies to series of arbitrary length.

10. Let m be a positive integer and consider the sum $\frac{1}{m} + \frac{1}{m+1} + \frac{1}{m+2} + \cdots + \frac{1}{2m}$.

(a) Show that this sum is greater than $1/2$, for any m .

(b) Show that this sum approaches a positive limit as m approaches infinity.

11. What is the relation between the solution curves for the differential equation $\frac{dy}{dx} = \frac{1}{2}y$ and the solution curves for the differential equation $\frac{dy}{dx} = -\frac{2}{y}$? Find equations for the two curves (one from each family) that go through the point $(0, 2)$.

12. If $\sum a_n$ converges, then $a_n \rightarrow 0$ as $n \rightarrow \infty$. Explain. Is the converse also true?

Mathematics 4C

1. If the series $\sum_{n=1}^{\infty} a_n$ and $\sum_{n=1}^{\infty} b_n$ are convergent, then so is $\sum_{n=1}^{\infty} (a_n + b_n)$. Explain.

2. It is difficult to analyze *nonpositive series* such as $\frac{\cos 1}{1} + \frac{\cos 2}{4} + \frac{\cos 3}{9} + \dots = \sum_{n=1}^{\infty} \frac{\cos n}{n^2}$, because they cannot be directly compared with integrals or with other series.

(a) The signs of the first five terms of this series are positive, negative, negative, negative, and positive. Is there an overall pattern to the signs in this series?

(b) Although $\sum_{n=1}^{\infty} \frac{\cos n}{n^2}$ cannot be compared with other series, $\sum_{n=1}^{\infty} \left| \frac{\cos n}{n^2} \right|$ can be. Show that this positive series converges, by finding a convergent series that has larger terms.

(c) Because $\sum_{n=1}^{\infty} \left| \frac{\cos n}{n^2} \right|$ converges, a suitably large N makes its tail $\sum_{n=N}^{\infty} \left| \frac{\cos n}{n^2} \right|$ arbitrarily

small. Show that the same is true of the tail $\sum_{n=N}^{\infty} \frac{\cos n}{n^2}$. Thus $\sum_{n=1}^{\infty} \frac{\cos n}{n^2}$ converges.

3. (Continuation) Give another example of a nonpositive series $\sum a_n$ for which $\sum |a_n|$ is known to converge. Explain why $\sum a_n$ must therefore converge, regardless of the pattern of its signs. Such a series is called *absolutely convergent*.

4. (Continuation) The series $1 - \frac{1}{2} + \frac{1}{3} - \frac{1}{4} + \dots = \sum_{n=1}^{\infty} (-1)^{n+1} \frac{1}{n}$ is called the *alternating harmonic series*. It is known to converge. Why? You have in fact shown that the sum is $\ln 2$. Does the alternating harmonic series provide an efficient way of calculating a value for $\ln 2$? Explain why this convergent series is *not* an absolutely convergent series.

5. When the curve $y = \sqrt{x}$ for $2 \leq x \leq 6$ is revolved around the x -axis, a surface called a *paraboloid* is obtained. One way to approximate the *area* of this surface is to slice it into many thin ribbons, using cutting planes that are perpendicular to the x -axis. The diagram may help you visualize this process. Each of these thin ribbons is very nearly a *frustum*. Explain

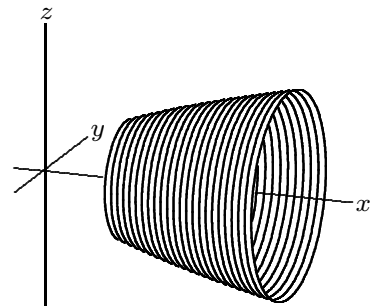

why the value of the integral $\int_2^6 2\pi\sqrt{x} \sqrt{1 + \left(\frac{1}{2\sqrt{x}}\right)^2} dx$ is numerically equal to the surface area of the paraboloid. Evaluate the integral.

6. The Ratio Test applies only to positive series, thus it detects only *absolute* convergence. Explain. Use this test to determine values of x for which each series (absolutely) converges:

(a) $\sum_{n=0}^{\infty} \frac{x^{2n}}{(2n+1)!}$ (b) $\sum_{n=1}^{\infty} n!x^n$ (c) $\sum_{n=1}^{\infty} \frac{n!}{n^n} x^n$ (d) $\sum_{n=1}^{\infty} (-1)^{n-1} \frac{1}{n} (x-1)^n$

Mathematics 4C

1. A series that converges without converging absolutely is called *conditionally convergent*. Such a series converges, but *only* because it has a mixture of positive and negative terms. Make up two examples of conditionally convergent series.

2. Suppose that $1 = \int_a^b g(x) dx$, where $g(x)$ is nonnegative and continuous for $a \leq x \leq b$. If function f is continuous for $a \leq x \leq b$, then $\int_a^b f(x)g(x) dx$ is called a *weighted average* of the values of f . A familiar example is $g(x) = \frac{1}{b-a}$. Discuss the general case, explaining why any weighted average of f -values must equal $f(c)$, for some c that is between a and b .

3. *A new approach to Taylor series.* Assume that f is infinitely differentiable on an interval that includes a and b . In other words, assume that $f(x), f'(x), f''(x), f'''(x), \dots$ all exist for $a \leq x \leq b$. Now calculate $f(b)$, using $f(a), f'(a), f''(a), f'''(a), \dots$

(a) The first step is accomplished by $f(b) = f(a) + \int_a^b f'(x) dx$. Justify this equation.

(b) Justify $\int_a^b f'(x) dx = f'(x) \cdot x \Big|_a^b - \int_a^b f''(x) \cdot x dx$.

(c) Show that the preceding can be rearranged as

$$f(b) = f(a) + f'(a) \cdot (b-a) + [f'(b) \cdot b - f'(a) \cdot b] - \int_a^b f''(x) \cdot x dx.$$

(d) Explain why this can be rewritten as

$$f(b) = f(a) + f'(a) \cdot (b-a) + \int_a^b f''(x) \cdot (b-x) dx.$$

(e) Apply Integration by Parts again to obtain

$$f(b) = f(a) + f'(a) \cdot (b-a) + \frac{1}{2} f''(a) \cdot (b-a)^2 + \int_a^b f'''(x) \cdot \frac{1}{2} (b-x)^2 dx.$$

(f) The pattern should now be clear. The general formulation looks like the Extended Mean-Value Theorem, except for the integral form of the last term. This version is known as *Taylor's Theorem*. Write a careful description of it.

4. (Continuation) The last term does not always approach zero as the number of terms increases. For example, apply the preceding development to the example $f(x) = \ln x$, with $a = 1$ and $b = 3$. Show that the case $b = 1/3$ solves the problem of calculating $\ln 3$.

5. (Continuation) By using a weighted average, show that $\int_a^b f^{(n+1)}(x) \cdot \frac{1}{n!} (b-x)^n dx$ is equal to $f^{(n+1)}(c) \frac{1}{(n+1)!} (b-a)^{n+1}$ for some c that is between a and b . This shows that the Taylor error formula is at least as strong as the Lagrange error formula.

6. *Limit comparison test.* Suppose that $\{a_n\}$ and $\{b_n\}$ are two positive sequences, and that $\lim_{n \rightarrow \infty} (a_n/b_n)$ is a positive number L . Thus $a_n \approx Lb_n$ when n is large.

(a) Show that $a_n < (L+1)b_n$ and $b_n < (2/L)a_n$ are both true for all suitably large n .

(b) The infinite series $\sum a_n$ and $\sum b_n$ either both converge or both diverge. Explain.

(c) Discuss the convergence of $\sum_{n=1}^{\infty} 1/(n + \ln n)$.

Mathematics 4C

1. Consider the non-geometric series $S(x) = 1 + 2x + 3x^2 + 4x^3 + \dots = \sum_{n=1}^{\infty} nx^{n-1}$.

The terms of this series suggest that antidifferentiation may be of some help in finding a compact formula for $S(x)$. Explore this approach.

2. Surface \mathcal{S} results from revolving a curve $y = f(x)$ for $a \leq x \leq b$ around the x -axis. Explain why the area of \mathcal{S} equals the integral $\int_a^b 2\pi f(x)\sqrt{1+f'(x)^2} dx$. Find the area of

- (a) the cone obtained by revolving $y = mx$ for $0 \leq x \leq 1$ around the x -axis;
- (b) the sphere obtained by revolving $y = \sqrt{1-x^2}$ for $-1 \leq x \leq 1$ around the x -axis.

3. Consider the function defined by $f(x) = \frac{1}{2} \ln \frac{1+x}{1-x}$.

- (a) Find the domain of x -values, and show that f is an increasing function.
- (b) Find an explicit formula for the inverse function f^{-1} .
- (c) Find a compact formula for the coefficients of the Maclaurin series for f . What is the *interval of convergence* of this series? What is the *radius of convergence*?
- (d) What is the sum of the Maclaurin series when $x = \frac{1}{2}$? Show that *any* value of $\ln k$ can be calculated by substituting a suitable value for x into the Maclaurin series for f . Notice that there is no easy way to estimate the approximation error for this series. In particular, show that the next term in the series does *not* overestimate the error.

4. The figure at right shows a tower of congruent blocks. The length of each block is 2 cm. Such a tower is stable provided that the combined centroid of all the blocks that lie above a given block \mathcal{B} lies directly over a point of \mathcal{B} . For example, the top block can (precariously) overhang by nearly 1 cm the block on which it rests.

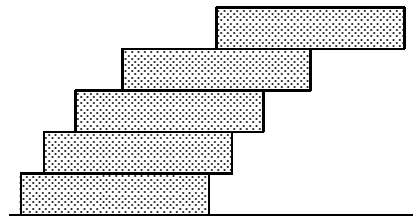

- (a) How large an overhang can be created using three of these blocks?
- (b) Explain why it is possible to make a stable tower of five blocks so that no part of the top block lies above any part of the bottom block, as shown in the figure.
- (c) How large an overhang can be created using a hundred of these blocks?

5. The area of the spherical surface $x^2 + y^2 + z^2 = 1$ is 4π . How much of this area is found between the planes $z = 0$ and $z = \frac{1}{2}$? How much is between the planes $z = -\frac{1}{4}$ and $z = \frac{1}{4}$? How much is between the planes $z = a$ and $z = b$, where $-1 \leq a < b \leq 1$?

6. Consider the sequence $x_n = \left(\frac{1}{2}\right)^n \left| \sin \frac{n\pi}{2} \right| - \frac{1}{n} \left| \cos \frac{n\pi}{2} \right|$ for $n = 1, 2, 3, \dots$

- (a) Write out the first four terms of this sequence, and show that $x_n \rightarrow 0$ as $n \rightarrow \infty$.
- (b) Is the series $\sum_{n=1}^{\infty} x_n$ alternating? Explain. Does it converge? Explain.

Mathematics 4C

1. By examining ratios, determine the convergence or divergence of the following:

(a) $\sum_{n=0}^{\infty} \frac{2^n}{n!}$ (b) $\sum_{n=3}^{\infty} \frac{n^5}{3^n}$ (c) $\sum_{n=1}^{\infty} n \left(\frac{13}{21}\right)^{n-1}$ (d) $\sum_{n=1}^{\infty} \frac{n}{2n+1}$

2. If surface \mathcal{S} results from revolving a parametrically defined curve $x = f(t)$, $y = g(t)$ for $a \leq t \leq b$ around the x -axis, then the area of \mathcal{S} equals $\int_a^b 2\pi g(t) \sqrt{f'(t)^2 + g'(t)^2} dt$.

Explain why, then find the area of

- (a) the sphere obtained by revolving $x = \cos t$, $y = \sin t$ for $0 \leq t \leq \pi$ around the x -axis;
 (b) the cycloidal surface obtained by revolving $x = t - \sin t$, $y = 1 - \cos t$ for $0 \leq t \leq 2\pi$ around the x -axis.

3. As you have seen, a spherical loaf of bread has the *equal-crust property*: Any two slices of bread of equal thickness cut from the same spherical loaf will have the same amount of crust. It is clear that a cylindrical loaf also has the equal-crust property. One wonders if there are *other* surfaces of revolution that have this property.

(a) If function f satisfies the equation $mx = \int_0^x 2\pi f(t) \sqrt{1 + f'(t)^2} dt$ for $0 \leq x \leq L$, then the loaf obtained by revolving the region $0 \leq y \leq f(x)$ for $0 \leq x \leq L$ about the x -axis will have the equal-crust property. Explain why. The positive number m is a constant of proportionality, while the positive number L is the length of the loaf.

(b) To solve this equation for f , first differentiate both sides with respect to x , then solve the resulting separable differential equation. Are the solutions what you expected?

4. The figure at right shows part of the Archimedean spiral $r = \theta$, for $0 \leq \theta \leq 40\pi$. Find the length of this curve. Compare your answer to the estimate $800\pi^2$, and explain the logic behind this approximation. Make a similar estimate for the spiral defined on the interval $0 \leq \theta \leq 2n\pi$, and compare it to the exact answer.

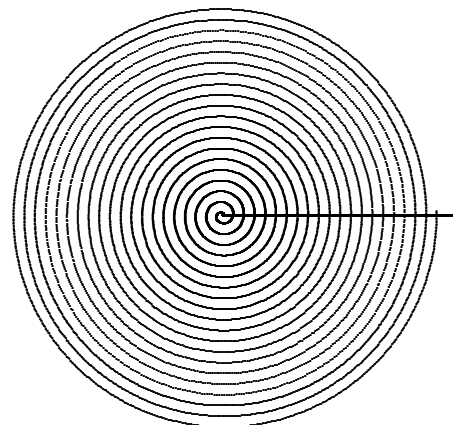

5. An open hemispherical bowl of radius R is slowly draining through a small hole of radius r in the bottom of the bowl. Let g be the acceleration due to gravity and y be the depth of the water (which means the distance from the water surface to the hole). Torricelli's Law states that the speed of the droplets leaving the hole is $\sqrt{2gy}$. (This is actually the speed that the droplets would acquire by falling from the water surface to the hole.)

- (a) What is the meaning of the expression $\pi r^2 \sqrt{2gy}$?
 (b) In terms of y , what is the area of the water surface when the water is y cm deep?
 (c) Assume that the bowl is initially full. How much time will be needed to drain it?

6. Show that $x - \frac{1}{6}x^3 + \frac{1}{120}x^5 - \sin x$ is positive whenever x is positive.

Mathematics 4C

1. Use Maclaurin series (instead of l'Hôpital's Rule) to evaluate $\lim_{t \rightarrow 0} \frac{t \cos t - \sin t}{t - \sin t}$.
2. Consider the cylinder $y^2 + z^2 = 1$, whose axis is the x -axis, and the cylinder $x^2 + z^2 = 1$, whose axis is the y -axis, and let \mathcal{C} be the region that is common to both cylinders.
 - (a) Explain why the volume of \mathcal{C} is more than $\frac{4}{3}\pi$ and less than 8.
 - (b) What section is obtained when \mathcal{C} is sliced by a plane that is parallel to the xy -plane?
 - (c) Set up and evaluate an integral for the volume of \mathcal{C} .

3. *The seesaw principle:* As you probably know, any two persons can balance each other when sitting on opposite sides of a seesaw, regardless of their weights. It is necessary only that each person contribute the same *moment* — calculated by multiplying the person's weight times the distance to the fulcrum. For example, if an 80-pound child sits at one end of a 20-foot plank, 10 feet from the fulcrum, a 200-pound adult can balance this system. Tell how.

4. (Continuation) The region \mathcal{R} shown at right is enclosed by the x -axis and the parabolic graph of $y = 15 - x^2$. The centroid of \mathcal{R} is $(0, 6)$, which you need not verify. Think of the diagram as the top view of a seesaw that uses the dashed line $y = 6$ for its fulcrum.

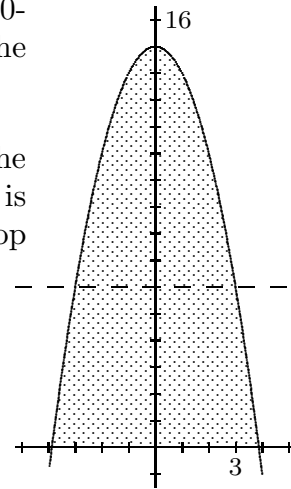

(a) Explain why the equality of the integrals

$$\int_6^{15} (y - 6)2x \, dy = \int_0^6 (6 - y)2x \, dy$$

demonstrates that the seesaw is in balance. Evaluate the integrals to confirm that they *are* equal in value.

- (b) Simplify the preceding equation to $\int_0^{15} (y - 6)2x \, dy = 0$.
- (c) Rearrange the preceding equation to $\int_0^{15} y 2x \, dy = 6 \int_0^{15} 2x \, dy$. Look familiar?
- (d) By means of an integral, show that the line $y = 6$ does *not* bisect the area of \mathcal{R} .

5. The value of the integral $\int_0^{\pi/2} \frac{\sin^4 x}{\sin^4 x + \cos^4 x} \, dx$ can be obtained mentally. Try it.

6. Consider the familiar curve traced parametrically by $(x, y) = \left(\frac{1-t^2}{1+t^2}, \frac{2t}{1+t^2} \right)$.

(a) Evaluate the expressions $\lim_{t \rightarrow \infty} \frac{1-t^2}{1+t^2}$, $\lim_{t \rightarrow -\infty} \frac{1-t^2}{1+t^2}$, $\lim_{t \rightarrow \infty} \frac{2t}{1+t^2}$, and $\lim_{t \rightarrow -\infty} \frac{2t}{1+t^2}$.

(b) Simplify the arclength differential $ds = dt \sqrt{\left(\frac{dx}{dt}\right)^2 + \left(\frac{dy}{dt}\right)^2}$.

(c) Show that the integral $\int_{-\infty}^{\infty} \frac{ds}{dt} \, dt$ has a familiar value.

7. Does the geometric series $18 - 6 + 2 - \frac{2}{3} + \frac{2}{9} - \dots$ converge conditionally? Explain.

Mathematics 4C

1. When a semi-ellipse $(x, y) = (a \cos t, b \sin t)$ for $0 \leq t \leq \pi$ is revolved around its *major* axis ($b < a$ is assumed), the resulting surface is called a *prolate* ellipsoid. Show that the *area* of the prolate surface is $2\pi b \left(b + a \cdot \frac{a}{c} \arcsin \frac{c}{a} \right)$, where $c = \sqrt{a^2 - b^2}$.

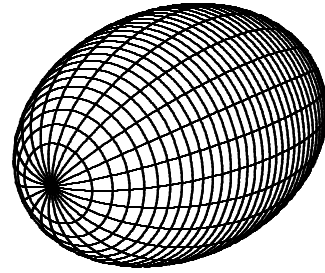

2. (Continuation) What happens to this area formula when b and a are nearly equal (and c is nearly zero)? *Hint:* What is the value of $\lim_{t \rightarrow 0} \frac{\arcsin t}{t}$?

3. Write $\frac{1}{x^3 + 1}$ as the sum of a geometric series. Integrate term-by-term to express $\int_0^1 \frac{1}{x^3 + 1} dx$ as an equivalent series of constants. Calculate the first few partial sums of this series, and compare them with $\frac{1}{3} \ln 2 + \frac{\pi}{9} \sqrt{3} = 0.8356\dots$, which is the exact value of the integral, obtainable by applying a partial-fractions approach to $\frac{1}{(x + 1)(x^2 - x + 1)}$.

4. In ancient times, a *clepsydra* was a bowl of water that was used to time speeches. As the water trickled out through a small hole in the bottom of the bowl, time was measured by watching the falling water level. Consider the special bowl that is obtained by revolving the curve $y = x^4$ for $0 \leq x \leq 1$ around the y -axis. Use Torricelli's Law to show that the water level in this bowl will drop *at a constant rate*.

5. Consider the cylinder $y^2 + z^2 = 1$, whose axis is the x -axis, the cylinder $z^2 + x^2 = 1$, whose axis is the y -axis, and the cylinder $x^2 + y^2 = 1$, whose axis is the z -axis. Let \mathcal{R} be the region that is common to all three cylinders. You know that the volume of \mathcal{R} is more than $\frac{4}{3}\pi$ and less than $\frac{16}{3}$. Find the exact volume of \mathcal{R} . Using symmetry shortens the calculations.

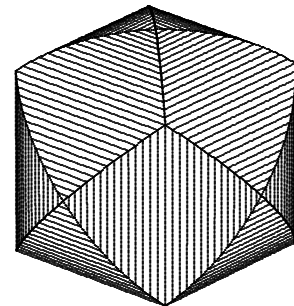

6. A cylindrical loaf of bread has the *proportional-crust property*:

The ratio of bread volume to crust is constant for any slice from the loaf. (There is no crust on the ends of the loaf.) Verify that this is true, then consider the problem of finding *other* surfaces of revolution that have this property.

(a) Explain why the problem is to find a function f and a positive constant k that satisfy the equation $\int_0^x \pi f(t)^2 dt = k \int_0^x 2\pi f(t) \sqrt{1 + f'(t)^2} dt$ on an interval $0 \leq x \leq L$.

(b) To solve this equation for f , first differentiate both sides with respect to x , then solve the resulting separable differential equation. Are the solutions what you expected?

7. Evaluate the integral $\int_0^{\pi/2} \frac{\sin^{45} x}{\cos^{45} x + \sin^{45} x} dx$ without a calculator. Justify your answer.

Mathematics 4C

1. The region \mathcal{R} shown is enclosed by the x -axis and the parabolic graph of $y = 9 - x^2$. The volume of the solid obtained by revolving \mathcal{R} about the x -axis is equal to the value of the integral $\int_0^9 2\pi y \cdot 2x \, dy$.

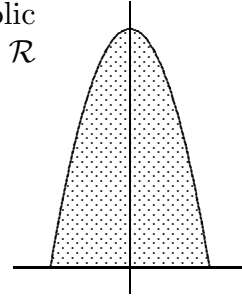

(a) Explain the method that was used to set up this integral. Then explain why this volume integral can be rewritten as $2\pi\bar{y} \int_0^9 2x \, dy$, where $\bar{y} = 3.6$ is the y -coordinate of the centroid of \mathcal{R} . The value of $\int_0^9 2x \, dy$ is 36; what is its meaning?

(b) This volume formula illustrates the *Theorem of Pappus*. If you can guess the statement of this result, you will not need integration to find the volume of the solid that is obtained when \mathcal{R} is revolved about the axis $y = -2$, or to find the volume of the solid that is obtained when \mathcal{R} is revolved about the axis $x = 5$.

2. Consider the series $1 + x + 2x^2 + 3x^3 + 5x^4 + 8x^5 + \dots$, in which the first two coefficients equal 1, and each subsequent coefficient is the sum of the two that precede it. In other words, the coefficients are the famous *Fibonacci numbers*. For those values of x that produce a convergent series, let $F(x)$ be the sum of the series. For example, $F(0) = 1$.

(a) Notice that $F(x)$ is undefined for all $x \leq -1$ and all $1 \leq x$. Explain why.

(b) Confirm that the given series is not geometric, by calculating a few ratios.

(c) The sum of a geometric series is found by the trick of multiplying the series by $1 - r$, where r is the given ratio. A modified version of the trick works here: Multiply both sides of the equation $F(x) = 1 + x + 2x^2 + 3x^3 + 5x^4 + 8x^5 + \dots$ by $1 - x - x^2$, and notice the dramatic effect this has on the right side. Obtain a formula for $F(x)$.

(d) Find the numbers p and q that make $1 - x - x^2 = (1 - px)(1 - qx)$ an identity. Without loss of generality, label them so that $q < 0 < p$.

(e) Find a and b to put $\frac{1}{1 - x - x^2}$ into partial-fraction form $\frac{a}{1 - px} + \frac{b}{1 - qx}$.

(f) The Maclaurin series for $\frac{a}{1 - px}$ is $a + apx + ap^2x^2 + ap^3x^3 + \dots$. What is the Maclaurin

series for $\frac{b}{1 - qx}$? What is the Maclaurin series for $\frac{a}{1 - px} + \frac{b}{1 - qx}$?

(g) Compare the two series formulas you now have for $F(x)$. Obtain an explicit formula for the n^{th} term of the Fibonacci sequence as a function of n . Test your formula on small values of n , then try calculating the 40th Fibonacci number directly.

(h) What is the interval of convergence for $F(x) = 1 + x + 2x^2 + 3x^3 + 5x^4 + \dots$?

3. A *torus* (a mathematical term used to describe the surface of a bagel) is obtained by revolving a circle of radius a around an axis that is b units from the circle center. Without doing any integration, provide an intuitive value for the *area* of this surface, and explain your thinking. Then confirm your answer by setting up and evaluating a suitable integral.

4. Find the following sums: (a) $1 + \sin^2 x + \sin^4 x + \dots = \sum_{n=0}^{\infty} \sin^{2n} x$ (b) $\sum_{n=0}^{\infty} \left(\frac{e}{\pi}\right)^n$

5. *Limit comparison test*. Suppose that $\{a_n\}$ and $\{b_n\}$ are two positive sequences, and that $\lim_{n \rightarrow \infty} (a_n/b_n)$ is 0. If $\sum b_n$ converges, what can be said about $\sum a_n$? If $\sum a_n$ diverges, what can be said about $\sum b_n$? If $\sum a_n$ converges, what can be said about $\sum b_n$?

Mathematics 4C

1. A police helicopter H is using radar to check the speed of a red convertible C on the highway below. The radar shows that the helicopter-car distance HC is 1250 feet and increasing at 66 feet per second, at an instant when the helicopter altitude HF is 1000 feet, and dropping at 12 feet per second. How fast is the car going, to the nearest mile per hour?

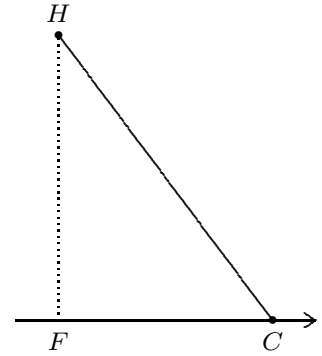

2. A function f is defined for all x , and it has the special property that the average of its values over any interval $a \leq x \leq b$ is just $\frac{1}{2}(f(a) + f(b))$, the average of the functional values at the endpoints of that interval. Given that $f(0) = 3960$ and $f(5280) = 0$, find $f(1999)$.

3. Evaluate: (a) $\lim_{x \rightarrow \infty} x^{100} e^{-x}$ (b) $\lim_{x \rightarrow 0} \frac{x^4}{x^2 - 2 + 2 \cos x}$ (c) $\int_1^{e^\pi} \sin(\ln x) dx$

4. Use the first four terms of the Maclaurin series for $\ln(1+x)$ to calculate values for $\ln \frac{4}{3}$, $\ln \frac{5}{4}$, and $\ln \frac{6}{5}$. Estimate the accuracy of these approximations, then combine them to obtain an approximation for $\ln 2$. Estimate the accuracy of this approximation. How many terms of the series for $\ln 2$ would be needed to achieve the same accuracy?

5. The trapezoidal and parabolic methods both involve the same amount of work, but one usually delivers greater accuracy. Compare the two on an integral of your choosing.

6. When applied to an integral of a quadratic function, Simpson's method produces the exact value of the integral, of course. Show that perfect accuracy is also obtained when Simpson's method is used to integrate cubic functions. In establishing this result, why does it suffice to consider the example $f(x) = x^3$?

7. The diagram at right shows the first five terms of a graphical representation of the series $1 + 2 \cdot \frac{1}{2} + 3 \cdot \frac{1}{4} + 4 \cdot \frac{1}{8} + \dots = \sum_{n=1}^{\infty} n \left(\frac{1}{2}\right)^{n-1}$. You have already learned at least one way to find the sum of this series. Show that another way of proceeding is to replace the system of vertical rectangles by a system of horizontal rectangles.

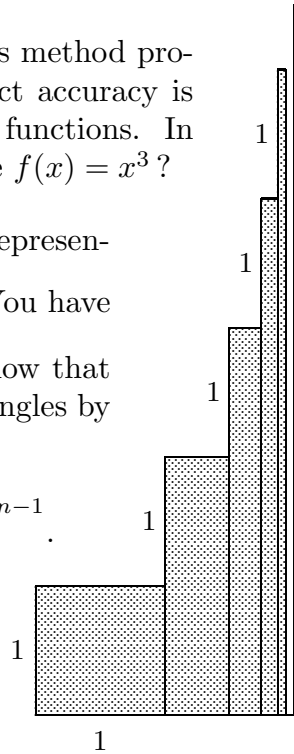

8. Evaluate the sum $1 + 2 \cdot \frac{1}{5} + 3 \cdot \frac{1}{25} + 4 \cdot \frac{1}{125} + \dots = \sum_{n=1}^{\infty} n \left(\frac{1}{5}\right)^{n-1}$.

9. There are many techniques for evaluating $\int_0^{2\pi} \cos^2 x dx$. Find as many as you can. The easiest method pays particular attention to the limits on this integral!

Mathematics 4C

1. Consider the region enclosed by the x -axis and the graph of $y = 1 - x^{2n}$, where n is a positive integer. When $n = 1$, the centroid of this region is $(0, \frac{2}{5})$. Find the y -coordinate of the centroid as a function of n . What is the limit of this coordinate as n approaches infinity?

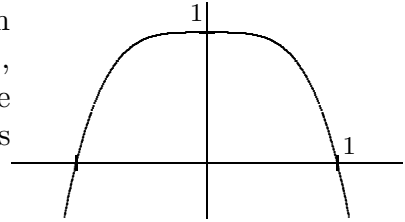

2. As the Earth travels in its orbit, its distance from the Sun varies. Describe two different approaches to the problem of calculating a number that could be called the *average distance between the Earth and the Sun*.

3. One of the focal points of the ellipse $9x^2 + 25y^2 = 225$ is $F = (4, 0)$. What is the average distance from F to a point on the ellipse? Another version of the same question: What is the average distance from F to a point on the ellipse $(x, y) = (5 \cos t, 3 \sin t)$?

4. (Continuation) The origin is one of the focal points of the ellipse $r = \frac{9}{5 - 4 \cos \theta}$. What is the average distance from a point on the ellipse to this focal point? A numerical answer from your calculator is sufficient.

5. The length of one arch of the cycloid $(x, y) = (t - \sin t, 1 - \cos t)$ is exactly 8. Find coordinates for the point on this curve that is 2 units from the origin, the distance being measured *along the curve*.

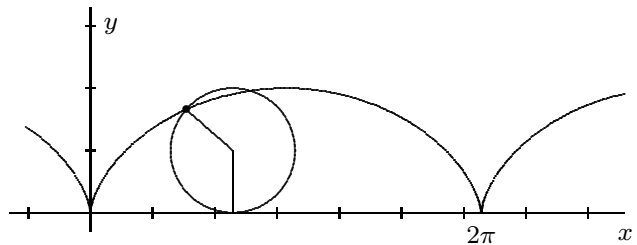

6. The Theorem of Pappus can be modified so that it applies to surfaces of revolution: Given a differentiable arc and an axis that both lie in the same plane, the area of the surface of revolution generated by the arc and the axis is the product of the arc length and the circumference of the circle traced by the centroid of the arc.

(a) Look through the surface area examples you have done and find two examples that confirm the statement of this theorem.

(b) Prove the theorem.

7. The spiral $r = e^{k\theta}$ (shown at right for $k = 3$) can also be described by the parametric equations $x = e^{k\theta} \cos \theta$ and $y = e^{k\theta} \sin \theta$. Use these equations to show that the cosine of the acute angle at $P = (x, y)$ formed by the radius vector and a tangent vector is $\frac{|k|}{\sqrt{1 + k^2}}$, a value that does not depend on θ . This is why this spiral is called *equiangular*.

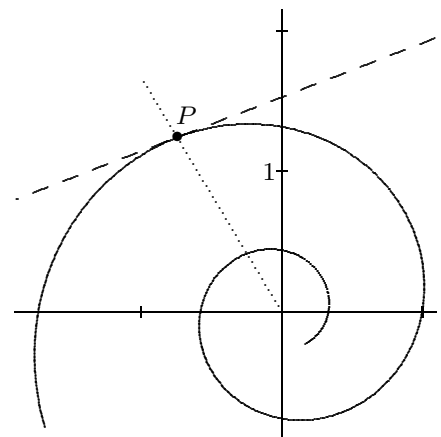

Mathematics 4C

1. *Buffon's needle problem.* Needles of unit length are tossed onto a plane surface that has been ruled by parallel lines that are 2 units apart. The probability that a given needle will land touching one of the lines is about 31.8%. Explain. (*Hint:* Let x be the distance from the center of the needle to the nearest line. If $x \leq 0.5$, then $\frac{2}{\pi} \cos^{-1} 2x$ is the probability that the line is touched by the needle, otherwise the probability is 0.)

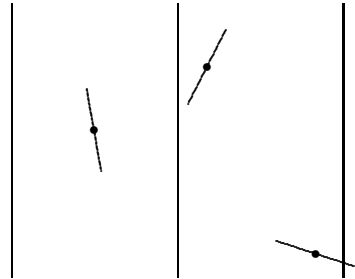

2. Suppose that f is a continuous function on a domain that includes a , and that $f'(x)$ exists whenever $x \neq a$. Suppose also that $L = \lim_{x \rightarrow a} f'(x)$ exists. Then f is differentiable at a as well, and $f'(a) = L$. Prove this statement.

3. Consider the region \mathcal{R} that is enclosed by the curve $y = \sin x$ and the x -axis segment $0 \leq x \leq \pi$. When \mathcal{R} is revolved around the x -axis, the resulting solid is shaped like an American football. Find exact formulas for its volume and its surface area.

4. Consider the function f defined for all x by the rule $f(x) = \begin{cases} x^2 \sin \frac{1}{x} & \text{for } x \neq 0 \\ 0 & \text{for } x = 0 \end{cases}$.

- (a) Show that f is continuous at $x = 0$.
- (b) Calculate $f'(x)$ for nonzero values of x .
- (c) Show that $\lim_{x \rightarrow 0} f'(x)$ does not exist.
- (d) Is f differentiable at $x = 0$? Justify your response.

Mathematics 4C Reference

absolutely convergent: A series Σa_n for which $\Sigma |a_n|$ converges. In other words, Σa_n converges, regardless of the pattern of its signs. [116]

acceleration: The rate of change of velocity. [51]

accumulate: To integrate a function, which becomes the rate of accumulation. [61]

alternating series: A *series* in which every other term is positive. [102,118]

angle-addition identities: For any angles α and β , $\cos(\alpha + \beta) \equiv \cos \alpha \cos \beta - \sin \alpha \sin \beta$ and $\sin(\alpha + \beta) \equiv \sin \alpha \cos \beta + \cos \alpha \sin \beta$.

angle between vectors: When two vectors \mathbf{u} and \mathbf{v} are placed tail-to-tail, the angle θ they form can be calculated by the dot-product formula $\cos \theta = \frac{\mathbf{u} \cdot \mathbf{v}}{|\mathbf{u}| |\mathbf{v}|}$. If $\mathbf{u} \cdot \mathbf{v} = 0$ then \mathbf{u} is perpendicular to \mathbf{v} . If $\mathbf{u} \cdot \mathbf{v} < 0$ then \mathbf{u} and \mathbf{v} form an obtuse angle.

antiderivative: If f is the derivative of g , then g is called *an antiderivative of f* . For example, $g(x) = 2x\sqrt{x} + 5$ is an antiderivative of $f(x) = 3\sqrt{x}$, because $g' = f$. [37,40,60,61]

antidifferentiation by parts: A common approach to *integration by parts*. [87]

AP Questions: A few free-response questions are found on pages 80, 84, 108.

arc length: A common application of integration. [80,82,86,91,94]

arccos: This is another name for the inverse cosine function, commonly denoted \cos^{-1} .

arcsin: This is another name for the inverse sine function, commonly denoted \sin^{-1} .

arctan: This is another name for the inverse tangent function, commonly denoted \tan^{-1} .

Archimedean spiral: A spiral curve described in polar coordinates by $r = a\theta$. [17,119] Archimedes (287-212 BC) was a Greek problem-solver who invented integration.

arithmetic mean: The *arithmetic mean* of two numbers p and q is $\frac{1}{2}(p + q)$. [9]

arithmetic sequence: A list in which each term is obtained by adding a constant amount to the preceding term.

asteroid: Do not confuse a small, planet-like member of our solar system with an *astroid*.

astroid: A type of cycloid, this curve is traced by a point on a wheel that rolls without slipping around the inside of a circle whose radius is four times the radius of the wheel. [73,84] Leibniz studied the curve in 1715.

Mathematics 4C Reference

asymptote: Two graphs are *asymptotic* if they become indistinguishable as the plotted points get further from the origin. Either graph is an asymptote for the other. [3,12,16]

average value: If $f(x)$ is defined on an interval $a \leq x \leq b$, the average of the values of f on this interval is $\frac{1}{b-a} \int_a^b f(x) dx$. [67,68,73]

average velocity is displacement divided by elapsed time; it is calculated during a time interval.

Babylonian algorithm: Known to the Babylonians, this divide-and-average recursive process approximates the square root of any positive number p . Each approximation x_n is obtained from the preceding approximation x_{n-1} by forming the *arithmetic mean* of x_{n-1} and p/x_{n-1} . [9]

binomial coefficients: Numbers that appear when a binomial power $(x+y)^n$ is multiplied out. For example, $(x+y)^5 = 1x^5 + 5x^4y + 10x^3y^2 + 10x^2y^3 + 5xy^4 + 1y^5$, whose coefficients are 1, 5, 10, 10, 5, 1 — this is the fifth row of *Pascal's Triangle*.

cardioid: A *cycloid*, traced by a point on a circular wheel that rolls without slipping around another circular wheel of the same size. [101]

catenary: Modeled by the graph of the *hyperbolic cosine* function, this is the shape assumed by a hanging chain. [3,108]

center of curvature: Given points P and Q on a differentiable curve, let C be the intersection of the lines *normal* to the curve at P and Q . The limiting position of C as Q approaches P is the center of curvature of the curve at P . [58,73,75]

centroid of a region: Of all the points in the region, this is their average. [95,97,103]

centroid of an arc: Of all the points on the arc, this is their average. [111,112]

Chain Rule: If a composite function is defined by $C(x) = f(g(x))$, its derivative is a product of derivatives, namely $C'(x) = f'(g(x))g'(x)$. [36]

chord: A segment that joins two points on a curve. [86]

cis θ : Stands for the unit complex number $\cos \theta + i \sin \theta$. Also known as $e^{i\theta}$. [5,23,39]

combination: An *unordered* collection of things, typically chosen from a (larger) collection. There are ${}_n C_r = n \cdot (n-1) \cdots (n+1-r)/r!$ ways to choose r things from n things. The numbers ${}_n C_r$ form the n^{th} row of *Pascal's Triangle*. [16]

Mathematics 4C Reference

comparison of series: Given two infinite series Σa_n and Σb_n , about which $0 < a_n \leq b_n$ is known to be true for all n , the convergence of Σb_n implies the convergence of Σa_n , and the divergence of Σa_n implies the divergence of Σb_n . [102,104,109,110,113,115,117]

complex multiplication: The rule is $(a + bi)(c + di) = (ac - bd) + (bc + ad)i$ in Cartesian mode, and it is $(r_1 \text{cis} \theta_1)(r_2 \text{cis} \theta_2) = r_1 r_2 \text{cis}(\theta_1 + \theta_2)$ in polar mode. [13]

components of velocity: See *velocity vector*.

composite: A function that is obtained by applying two functions in succession. For example, $f(x) = (2x - 60)^3$ is a composite of $g(x) = 2x - 60$ and $h(x) = x^3$, because $f(x) = h(g(x))$. Another composite of g and h is $k(x) = g(h(x)) = 2x^3 - 60$. Notice also that f is a composite of $p(x) = 2x$ and $q(x) = (x - 60)^3$. [6,36]

compound interest: When interest is left in an account (instead of being withdrawn), the additional money in the account itself earns interest. [7]

concavity: A graph $y = f(x)$ is *concave up* on an interval if f'' is positive on the interval. The graph is *concave down* on an interval if f'' is negative on the interval. [44,64]

conditionally convergent: A convergent series Σa_n for which $\Sigma |a_n|$ diverges. [117]

conic section: Any graph obtainable by slicing a cone with a cutting plane. This might be an ellipse, a parabola, a hyperbola, or some other special case. [12,94]

conjugate: Irrational roots to polynomial equations sometimes come in pairs. [14,20]

constant function: A function that has only one value. [57,78]

continuity: A function f is *continuous at a* if $f(a) = \lim_{x \rightarrow a} f(x)$. A function is called *continuous* if it is continuous at every point in its domain. For example, $f(x) = 1/x$ (which is undefined at $x = 0$) is continuous. If a function is continuous at every point in an interval, the function is said to be continuous *on* that interval. [24,42,47,58]

converge (sequence): If the terms of a *sequence* come arbitrarily close to a fixed value, the sequence is said to *converge* to that value. [8,13]

converge (series): If the *partial sums* of an infinite *series* come arbitrarily close to a fixed value, the series is said to *converge* to that value. [7,96,102,104,106]

converge (integral): An *improper integral* that has a finite value is said to *converge* to that value, which is defined using a limit of proper integrals. [74,76,91]

cosecant: The reciprocal of the sine. [53]

Mathematics 4C Reference

cosh: See *hyperbolic functions*.

critical point: A number c in the domain of a function f is called *critical* if $f'(c) = 0$ or if $f'(c)$ is undefined. [62]

cross-sections: A method of calculating the volume of a solid figure, which partitions the solid by a system of 2-dimensional slices that are all perpendicular to a fixed axis. [63,68,71,73]

curvature: In an absolute sense, the rate at which the direction of a curve is changing, with respect to the distance traveled along it. For a circle, this is just the reciprocal of the radius. [58,61,73] The sign of the curvature indicates on which side of the tangent vector the curve is found. [64]

cycloid: A curve traced by a point on a wheel that rolls without slipping. Galileo named the curve, and *Torricelli* was the first to find its area. [60,75,92]

cylindrical shells: A system of thin-walled, coaxial tubes that dissect a given solid of revolution; used to set up a definite integral for the volume of the solid. [80]

Darth Vader: [69]

De Moivre's Theorem: For any number α and integer n , $\text{cis}(\alpha)^n = \text{cis}(n\alpha)$. [11] Abraham de Moivre (1667-1754) made original contributions to probability theory, and also discovered Stirling's formula.

decreasing: A function f is *decreasing* on an interval $a \leq x \leq b$ if $f(v) < f(u)$ holds whenever $a \leq u < v \leq b$ does. [33,43]

degree: See *polynomial degree*.

derivative: Given a function f , its derivative is another function f' , whose values are defined by $f'(a) = \lim_{h \rightarrow 0} \frac{f(a+h) - f(a)}{h}$, which is the derivative of f at a . [27]

derivative at a point: Given a function f , its *derivative at a* is the limiting value of the difference quotient $\frac{f(x) - f(a)}{x - a}$ as x approaches a . [27]

difference quotient: The slope of a chord that joins two points $(a, f(a))$ and $(b, f(b))$ on a graph $y = f(x)$ is $\frac{f(b) - f(a)}{b - a}$, a quotient of two differences. [29]

differentiable: A function that has derivatives at all the points in its domain. [34]

differential equation: An equation that is expressed in terms of an unknown function and its derivative. A solution to a differential equation is a function. [48]

Mathematics 4C Reference

differentials: Things like dx , dt , and dy . Called “ghosts of departed quantities” by George Berkeley (1685-1753), who was skeptical of Newton’s approach to mathematics.

differentiation: The process of finding a derivative, perhaps by evaluating the limit of a difference quotient, perhaps by applying a formula such as the *Power Rule*. [29]

discontinuous: A function f has a *discontinuity at a* if $f(a)$ is defined but does not equal $\lim_{x \rightarrow a} f(x)$; a function is *discontinuous* if it has one or more discontinuities. [24,46,54]

discriminant of a cubic: Calculated using the coefficients of a cubic equation, this number determines whether the equation has three real roots. [95]

diverge means *does not converge*. [91,104]

divide-and-average: A description of the *Babylonian* square-root algorithm. [15]

domain: The domain of a function consists of all the numbers for which the function returns a value. For example, the domain of a logarithm function consists of positive numbers only.

double-angle identities: Best-known are $\sin 2\theta \equiv 2 \sin \theta \cos \theta$, $\cos 2\theta \equiv 2 \cos^2 \theta - 1$, and $\cos 2\theta \equiv 1 - 2 \sin^2 \theta$; special cases of the *angle-addition identities*. [75,81,97]

e is approximately 2.71828. This irrational number frequently appears in scientific investigations. One of the many ways of defining it is $e = \lim_{n \rightarrow \infty} \left(1 + \frac{1}{n}\right)^n$. [7]

eccentricity: For curves defined by a focus and a directrix, this number determines the shape of the curve. It is the distance to the focus divided by the distance to the directrix, measured from any point on the curve. The eccentricity of an ellipse is less than 1, the eccentricity of a parabola is 1, and the eccentricity of a hyperbola is greater than 1. The eccentricity of a circle (a special ellipse) is 0. The word is pronounced “eck-sen-trissity”.

ellipse I: An ellipse is determined by a focal point, a directing line, and an eccentricity between 0 and 1. Measured from any point on the curve, the distance to the focus divided by the distance to the directrix is always equal to the eccentricity.

ellipse II: An ellipse has two focal points. The sum of the *focal radii* to any point on the ellipse is constant.

equal-crust property: Given a solid of revolution cut by two planes perpendicular to the axis of revolution, this rare property says that the surface area found between the planes is proportional to the separation between the planes. [118,119]

Mathematics 4C Reference

equiangular spiral: The angle formed by the radius vector and the tangent vector is the same at every point on the spiral. Any polar curve of the form $r = b^\theta$ has this property. [1,10,124]

Euler's formula states that $e^{i\theta} = \cos \theta + i \sin \theta$. [23,39] Leonhard Euler (1707-1783) was a prolific Swiss mathematician who did much of his work while blind. He was the first to find the exact value of the convergent series $\sum_{n=1}^{\infty} n^{-2}$. He had 13 children.

Euler's Method: Given a differential equation, a starting point, and a step size, this method provides an approximate numerical solution to the equation. [64,65,68,69,96]

even function: A function whose graph has reflective symmetry in the y -axis. Such a function satisfies the identity $f(x) = f(-x)$ for all x . The name *even* comes from the fact that $f(x) = x^n$ is an even function whenever the exponent n is an even integer. [2]

expected value: The average value of a variable whose values are randomly determined by a probability experiment (the number of aces when three dice are tossed, for example). The average is calculated by considering every possible outcome of the experiment. It may be expressed as $p_1v_1 + p_2v_2 + p_3v_3 + \cdots + p_nv_n$, in which each value v_k has been multiplied by the probability p_k that v_k will occur. The expected value need not be a value of the variable — the expected number of heads is 2.5 when five coins are tossed. [8,10,21,23] See also *weighted average*.

exponential functions have the strict form $f(x) = b^x$, with a constant base and a *variable exponent*. It is also common practice to use this terminology to refer to functions of the form $f(x) = k + a \cdot b^x$, although most of them do not satisfy the rules of exponents.

Extended Mean-Value Theorem: If f is a function that is $n + 1$ times differentiable for $0 \leq x \leq b$, then

$$f(b) = f(0) + f'(0)b + \frac{1}{2}f''(0)b^2 + \cdots + \frac{1}{n!}f^{(n)}(0)b^n + \frac{1}{(n+1)!}f^{(n+1)}(c)b^{n+1}$$

for some c between 0 and b . This version of the theorem is due to *Lagrange*. [108]

Extended Power Rule: The derivative of $p(x) = [f(x)]^n$ is $p'(x) = n[f(x)]^{n-1}f'(x)$. [47]

extreme point: either a *local minimum* or a *local maximum*. Also called an *extremum*.

Extreme-value Theorem: If $f(x)$ is continuous for $a \leq x \leq b$, then $f(x)$ attains a maximum and a minimum value. In other words, $m \leq f(x) \leq M$, where $m = f(p)$, $a \leq p \leq b$, $M = f(q)$, and $a \leq q \leq b$. Furthermore, p and q are critical values for f . [62]

factorial: The product of all positive integers less than or equal to n is called n *factorial*. The abbreviation $n!$ is generally used. For example, $5!$ is 120. In general, $n!$ is the number of permutations of n distinguishable objects.

Mathematics 4C Reference

Fibonacci sequence: A list of numbers, each of which is the sum of the two preceding. [15] Leonardo of Pisa (1180-1250), who was called *Fibonacci* (literally “Filius Bonaccio”), learned mathematics from his Arab teachers, and introduced algebra to Europe.

focal radius: A segment that joins a point on a conic section to one of the focal points; also used to indicate the length of such a segment.

folium: A cubic curve that René Descartes was the first to write about, in 1638. [93,103]

frustrum: There is no such word. See *frustum*.

frustum: When a cone is sliced by a cutting plane that is parallel to its base, one of the resulting pieces is another (similar) cone; the other piece is a *frustum*.

functional notation: For identification purposes, functions are given short names (usually just one to three letters long). If f is the name of a function, then $f(a)$ refers to the number that f assigns to the value a .

Fundamental Theorem of Algebra: Every complex polynomial of degree n can be factored (in essentially only one way) into n linear factors. [17]

Fundamental Theorem of Calculus: In a certain sense, differentiation and integration are inverse procedures. [61,67]

geometric mean: The *geometric mean* of two positive numbers p and q is \sqrt{pq} . [9]

geometric sequence: A list in which each term is obtained by applying a constant multiplier to the preceding term.

geometric series: Infinite examples take the form $a + ar + ar^2 + ar^3 + \dots = \sum_{n=0}^{\infty} ar^n$; they converge if and only if $|r| < 1$. The sum of such a series is $\frac{a}{1-r}$. [7,98,104]

global maximum: Given a function f , this may or may not exist. It is the value $f(c)$ that satisfies $f(x) \leq f(c)$ for all x in the domain of f . [62]

global minimum: Given a function f , this may or may not exist. It is the value $f(c)$ that satisfies $f(c) \leq f(x)$ for all x in the domain of f . [62]

Gödel’s Incompleteness Theorem. [207]

Greek letters: Apparently unavoidable in reading and writing mathematics! Some that are found in this book are α (alpha [31,34]), β (beta [31,34]), Δ (delta [28]), π (pi [32]), ψ (psi [57]), Σ (sigma [7]), and θ (theta [1]). Where does the word *alphabet* come from?

Mathematics 4C Reference

Gregory's series: The alternating sum of the reciprocals of odd integers is a convergent infinite series. Its sum is $\frac{1}{4}\pi$. [103]

half-life: When a quantity is described by a decreasing exponential function of t , this is the time needed for half of the current amount to disappear.

harmonic series: The sum of the reciprocals of the positive integers. [104]

Heaviside operator: The use of a symbol, such as D or D_x , to indicate the differentiation process. [39] The scientist Oliver Heaviside (1850-1925) advocated the use of vector methods, clarified Maxwell's equations, and introduced operator notation so that solving differential equations would become a workout in algebra.

hyperbola I: A hyperbola has two focal points, and the difference between the *focal radii* drawn to any point on the hyperbola is constant.

hyperbola II: A hyperbola is determined by a focal point, a directing line, and an eccentricity greater than 1. Measured from any point on the curve, the distance to the focus divided by the distance to the directrix is always equal to the eccentricity.

hyperbolic functions: Just as the properties of the circular functions \sin , \cos , and \tan are consequences of their definition using the unit circle $x^2 + y^2 = 1$, the analogous properties of \sinh , \cosh , and \tanh follow from their definition using the unit hyperbola $x^2 - y^2 = 1$. [98,221]

identity: An equation (sometimes written using \equiv) that is true no matter what values are assigned to the variables that appear in it. One example is $(x+y)^3 \equiv x^3 + 3x^2y + 3xy^2 + y^3$, and another is $\sin x \equiv \sin(180 - x)$. [4]

implicit differentiation: Applying a differentiation operator to an identity that has not yet been solved for a dependent variable in terms of its independent variable. [42]

implicitly defined function: Equations such as $x^2 + y^2 = 1$ do not express y explicitly in terms of x . As the examples $y = \sqrt{1 - x^2}$ and $y = -\sqrt{1 - x^2}$ illustrate, there in fact could be several values of y that correspond to a given value of x . These functions are said to be *implicitly defined* by the equation $x^2 + y^2 = 1$. [42]

improper fraction: Not a *proper fraction*.

improper integral: $\int_a^b f(x) dx$ is *improper* when either a or b is infinite or when the values $f(x)$ of the integrand are undefined, or not bounded, for all $a \leq x \leq b$. [74,76,81,88,91]

increasing: A function f is *increasing* on an interval $a \leq x \leq b$ if $f(u) < f(v)$ holds whenever $a \leq u < v \leq b$ does. [43]

Mathematics 4C Reference

indeterminate form: This is an ambiguous limit expression, whose actual value can be deduced only by looking at the given example. The five most common types are:

$$\frac{0}{0}, \text{ examples of which are } \lim_{t \rightarrow 0} \frac{\sin t}{t} \text{ and } \lim_{h \rightarrow 0} \frac{2^h - 1}{h} \quad [8,17,36,68,70]$$

$$1^\infty, \text{ examples of which are } \lim_{n \rightarrow \infty} \left(1 + \frac{1}{n}\right)^n \text{ and } \lim_{n \rightarrow \infty} \left(1 + \frac{2}{n}\right)^n \quad [7,11,105]$$

$$\frac{\infty}{\infty}, \text{ examples of which are } \lim_{x \rightarrow \infty} \frac{2x + 1}{3x + 5} \text{ and } \lim_{x \rightarrow 0} \frac{\log_2 x}{\log_3 x} \quad [13,85]$$

$$0 \cdot \infty, \text{ examples of which are } \lim_{x \rightarrow 0} x \ln x \text{ and } \lim_{x \rightarrow \pi/2} \left(x - \frac{1}{2}\pi\right) \tan x \quad [88]$$

$$\infty - \infty, \text{ examples being } \lim_{x \rightarrow \infty} \sqrt{x^2 + 4x} - x \text{ and } \lim_{x \rightarrow \pi/2} \sec x \tan x - \sec^2 x \quad [111]$$

The preceding limit examples all have different values.

infinite series: To find the sum of one of these, you must look at the limit of its partial sums. If the limit exists, the series *converges*; otherwise, it *diverges*. [96,114]

inflection point: A point on a graph $y = f(x)$ where f'' changes sign. [53,54,69]

instantaneous velocity is unmeasurable, and must therefore be calculated as a limiting value of average velocities, as the time interval diminishes to zero. [26,31]

integral: The precise answer to an accumulation problem. [61] A limit of *Riemann sums*.

integral test: A method of establishing convergence for positive, decreasing series of terms, by comparing them with improper integrals. [109]

integrand: A function that is integrated. [75]

integration by parts: An application of the product rule that allows one to conclude that two definite integrals have the same numerical value. See examples below. [81,87,222]

integration by substitution: Replacing the independent variable in a definite integral by some function of a new independent variable. The integral that results has the same numerical value as the original integral. [76,84,85,223]

intermediate-value property: A function f has this property if, for any k between $f(a)$ and $f(b)$, there is a number p between a and b , for which $k = f(p)$. For example, f has this property if it is *continuous* on the interval $a \leq x \leq b$. [82,85]

interval notation: A system of shorthand, in which " $a \leq x \leq b$ " is replaced by the statement " x is in $[a,b]$ ", and " θ is in $(0, 2\pi)$ " means $0 < \theta < 2\pi$. [42,68,70]

Mathematics 4C Reference

interval of convergence: Given a power series $\sum_{n=0}^{\infty} c_n(x-a)^n$, the x -values for which the series (absolutely) converges form an interval, by the *Ratio Test*. For example, the *geometric series* $\sum_{n=0}^{\infty} x^n$ converges for $-1 < x < 1$. [117,118] Also see *radius of convergence*.

inverse function: Any function f processes input values to obtain output values. A function that undoes what f does is said to be *inverse* to f , and often denoted f^{-1} . In other words, $f^{-1}(b) = a$ must hold whenever $f(a) = b$ does. For some functions ($f(x) = x^2$, for example), it is necessary to restrict the domain in order to define an inverse.

isocline: A curve, all of whose points are assigned the same slope by a differential equation. [70,73]

Lagrange's error formula: Given a function f and one of its Taylor polynomials p_n based at $x = a$, the difference between $f(x)$ and $p_n(x)$ is $\frac{1}{(n+1)!} f^{(n+1)}(c)(x-a)^{n+1}$, for some c that is between a and x . [108,109] Joseph Lagrange (1736-1813) made many contributions to calculus and analytic geometry, including a simple notation for derivatives.

Lagrange notation: The use of primes to indicate derivatives. [27]

Law of Cosines: This theorem can be expressed in the SAS form $c^2 = a^2 + b^2 - 2ab \cos C$ or in the equivalent SSS form $\cos C = \frac{a^2 + b^2 - c^2}{2ab}$.

Leibniz notation: A method of naming a derived function by making reference to the variables used to define the function. For example, the volume V of a sphere is a function of the radius r . The derivative of this function can be denoted $\frac{dV}{dr}$ instead of V' . [29] The philosopher Gottfried Wilhelm Leibniz (1646-1716) is given credit for inventing calculus (along with his contemporary, Isaac Newton).

l'Hôpital's Rule: A method for dealing with indeterminate forms: If f and g are differentiable, and $f(a) = 0 = g(a)$, then $\lim_{t \rightarrow a} \frac{f(t)}{g(t)}$ equals $\lim_{t \rightarrow a} \frac{f'(t)}{g'(t)}$, provided that the latter limit exists. [68,70] The Marquis de l'Hôpital (1661-1704) wrote the first textbook on calculus.

lemniscate: Given two focal points that are separated by a distance $2c$, the lemniscate consists of points for which the product of the focal radii is c^2 . [115]

limaçon: This cycloidal curve is traced by an arm of length $2r$ attached to a wheel of radius r that is rolling around a circle of the same size. [105] See also *cardioid*.

limit: A number that the terms of a sequence (or the values of a function) get arbitrarily close to. [1,2,3,7,8,15,114]

Mathematics 4C Reference

Limit Comparison Test: Provides a sufficient condition for the convergence of a positive series. [117,122]

linear interpolation: To calculate coordinates for an unknown point that is between two known points, this method makes the assumption that the three points are collinear.

Lissajous curve: Curve traced by $(x, y) = (f(t), g(t))$ when f and g are sinusoidal functions with a common period. [68] Jules Lissajous (1822-1880) was a physicist who extensively studied the interactions of a variety of oscillatory signals.

ln: An abbreviation of *natural logarithm*, it means \log_e . It should be read “log” or “natural log”. [10]

local maximum: Given a function f and a point c in its domain, $f(c)$ is a local maximum of f if there is a positive number d such that $f(x) \leq f(c)$ for all x in the domain of f that satisfy $|x - c| < d$.

local minimum: Given a function f and a point c in its domain, $f(c)$ is a local minimum of f if there is a positive number d such that $f(c) \leq f(x)$ for all x in the domain of f that satisfy $|x - c| < d$.

logarithm: The exponent needed to express a given positive number as a power of a given positive base. Using a base of 4, the logarithm of 64 is 3, because $64 = 4^3$.

logarithmic derivative: Dividing the derivative of a function by the function produces a relative rate of change. [28,43,74]

logarithmic spiral: A curve described in polar coordinates by an equation $r = a \cdot b^\theta$. [1]

logistic equation: A differential equation that describes population growth in situations where limited resources constrain the growth. [64,92]

long-division algorithm: The process by which an *improper fraction* is converted to a mixed fraction. For example, the polynomial division scheme shown at right was used to convert the improper fraction $\frac{2x^2 + 3}{x - 2}$ into the equivalent mixed form $2x + 4 + \frac{11}{x - 2}$. The process is terminated because the remainder 11 cannot be divided by $x - 2$. (In other words, $\frac{11}{x - 2}$ is a *proper fraction*.)

$$\begin{array}{r} 2x + 4 \\ x - 2 \overline{) 2x^2 + 0x + 3} \\ \underline{2x^2 - 4x} \\ 4x + 3 \\ \underline{4x - 8} \\ 11 \end{array}$$

Maclaurin polynomials: Given a highly differentiable function, the values of its derivatives at $x = 0$ are used to create these ideal approximating polynomials. They can be viewed as the partial sums of the Maclaurin *series* for the given function. [83,85,87,89,96] Colin Maclaurin (1698-1746) wrote papers about calculus and analytic geometry. He learned about Maclaurin series from the writings of Taylor and Stirling.

Mathematics 4C Reference

magnitude: For a complex number $a + bi$, the *magnitude* $|a + bi|$ is $\sqrt{a^2 + b^2}$. [4]

Mean-Value Theorem: If the curve $y = f(x)$ is continuous for $a \leq x \leq b$, and differentiable for $a < x < b$, then the slope of the line through $(a, f(a))$ and $(b, f(b))$ equals $f'(c)$, where c is strictly between a and b . [78,79] There is also a version of this statement that applies to integrals. [85]

megabucks: Slang for a million dollars, this has been used in the naming of lotteries. [8]

mho: The basic unit of conductance, which is the reciprocal of resistance, which is measured in ohms. This was probably someone's idea of a joke. [28]

mixed expression: The sum of a polynomial and a proper fraction, e.g. $2x - 3 + \frac{5x}{x^2 + 4}$.

moment: Quantifies the effect of a force that is magnified by applying it to a lever. Multiply the length of the lever by the magnitude of the force. [120]

monotonic: A function that either increases or decreases is called *monotonic*. [100,102]

natural logarithm: The exponent needed to express a given positive number as a power of e . [10]

Newton's Law of Cooling is described by exponential equations $D = D_0b^t$, in which t represents time, D is the difference between the temperature of the cooling object and the surrounding temperature, D_0 is the initial temperature difference, and b is a positive constant that incorporates the rate of cooling. [1] Isaac Newton (1642-1727) contributed deep, original ideas to physics and mathematics.

Newton's Method is a recursive process for solving equations of the form $f(x) = 0$. [90]

nondifferentiable: A function is nondifferentiable at a point if its graph does not have a tangent line at that point, or if the tangent line has no slope. [34,38]

normal line: The line that is perpendicular to a tangent line at the point of tangency. [58]

nth derivative: The standard notation for the result of performing n successive differentiations of a function f is $f^{(n)}$. For example, $f^{(6)}$ means f'''''' . It thus follows that $f^{(1)}$ means f' and $f^{(0)}$ means f . [87,96,101]

oblate: Describes the shape of the solid that is produced by revolving an elliptical region around its minor axis. The Earth is an oblate ellipsoid. See also *prolate*.

Mathematics 4C Reference

odd function: A function whose graph has half-turn symmetry at the origin. Such a function satisfies the identity $f(-x) = -f(x)$ for all x . The name *odd* comes from the fact that $f(x) = x^n$ is an odd function whenever the exponent n is an odd integer. [4]

one-sided limit: Just what the name says. [24,34,55,88,96,114]

operator notation: A method of naming a derivative by means of a prefix, usually D , as in $D \cos x = -\sin x$, or $\frac{d}{dx} \ln x = \frac{1}{x}$, or $D_x(u^x) = u^x(\ln u)D_x u$. [39]

oval: A differentiable curve that is closed, simple (does not intersect itself), convex (no line intersects it more than twice), and that has two perpendicular axes of symmetry of different lengths. [93]

Pappus's Theorem: To find the volume of a solid obtained by revolving a planar region \mathcal{R} around an axis in the same plane, simply multiply the area of \mathcal{R} by the circumference of the circle generated by the centroid of \mathcal{R} . [122]

parabola: This curve consists of all the points that are equidistant from a given point (the *focus*) and a given line (the *directrix*).

parabolic method: A method of numerical integration that approximates the integrand by a piecewise-quadratic function. [78]

partial fractions: Converting a proper fraction with a complicated denominator into a sum of fractions with simpler denominators, as in $\frac{3x+2}{x^2+x} = \frac{2}{x} + \frac{1}{x+1}$. [64,66,73]

partial sum: Given an infinite series $x_0+x_1+x_2+\dots$, the finite series $x_0+x_1+x_2+\dots+x_n$ is called the n^{th} *partial sum*. [7,96,102,106,114]

Pascal's triangle: The entries in the n^{th} row of this array appear as coefficients in the expanded binomial $(a+b)^n$. The r^{th} entry in the n^{th} row is ${}_nC_r$, the number of ways to choose r things from n things. Each entry in Pascal's Triangle is the sum of the two entries above it. Blaise Pascal (1623-1662) made original contributions to geometry and the theory of probability.

period: A function f has positive number p as a period if $f(x+p) = f(x)$ holds for all x .

permutation: An arrangement of objects. There are ${}_nP_r = n \cdot (n-1) \cdot \dots \cdot (n+1-r)$ ways to arrange r objects that are selected from a pool of n distinguishable objects.

piecewise-defined function: A function can be defined by different rules on different intervals of its domain. For example, $|x|$ equals x when $0 \leq x$, and $|x|$ equals $-x$ when $x < 0$. [34,66]

Mathematics 4C Reference

polar coordinates: Given a point P in the xy -plane, a pair of numbers $(r; \theta)$ can be assigned, in which r is the distance from P to the origin O , and θ is the size of an angle in standard position that has OP as its terminal ray. [1,2,92]

polar equation: An equation written using the polar variables r and θ . [1,2,12]

polar form of a complex number: The trigonometric form $r\text{cis } \theta = r(\cos \theta + i \sin \theta)$, which is also written $re^{i\theta}$. [5,9] See *cis* θ .

polynomial: A sum of terms, each being the product of a numerical coefficient and a nonnegative integer power of a variable, for examples $1 + t + 2t^2 + 3t^3 + 5t^4 + 8t^5$ and $2x^3 - 11x$.

polynomial degree: The degree of a polynomial is its largest exponent. For example, the degree of $p(x) = 2x^5 - 11x^3 + 6x^2 - 9x - 87$ is 5, and the degree of the constant polynomial $q(x) = 7$ is 0. [87,101,104]

polynomial division: See *long division*.

Power Rule: The derivative of $p(x) = x^n$ is $p'(x) = nx^{n-1}$. [27,29,34,36,38]

power series: A series of the form $\sum c_n(x - a)^n$. See also *Taylor series*. [104]

prismoidal formula: To find the average value of a quadratic function on an interval, add two thirds of the value at the center to one sixth of the sum of the values at the endpoints. [77]

Product Rule: The derivative of $p(x) = f(x)g(x)$ is $p'(x) = f(x)g'(x) + g(x)f'(x)$. [41]

prolate: Describes the shape of a solid that is produced by revolving an elliptical region around its major axis. [121]

proper fraction: The degree of the numerator is less than the degree of the denominator, as in $\frac{5x - 1}{x^2 + 4}$. Improper fractions can be converted by *long division* to *mixed expressions*.

proportional-crust property: Given a solid of revolution cut by two planes perpendicular to the axis of revolution, this rare property says that the surface area found between the planes is proportional to the volume found between the planes. [121]

quadratic formula: The solutions to $ax^2 + bx + c = 0$ are

$$x = \frac{-b + \sqrt{b^2 - 4ac}}{2a} \quad \text{and} \quad x = \frac{-b - \sqrt{b^2 - 4ac}}{2a} .$$

quadratic function: A polynomial function of the second degree. [22,33]

Mathematics 4C Reference

quartic function: A polynomial function of the fourth degree. [9]

Quotient Rule: The derivative of $p(x) = \frac{f(x)}{g(x)}$ is $p'(x) = \frac{g(x)f'(x) - f(x)g'(x)}{[g(x)]^2}$. [44,45]

radius of convergence: A *power series* $\sum c_n(x - a)^n$ converges for all x -values in an interval $a - r < x < a + r$ centered at a . The largest such r is the radius of convergence. It can be 0 or ∞ . [118]

radius of curvature: Given a point P on a differentiable curve, this is the distance from P to the *center of curvature* for that point. [58,59,61,65,69,75,83]

random walk: A sequence of points, each of which is obtained recursively and randomly from the preceding point. [5]

range: The range of a function consists of all possible values the function can return. For example, the range of the sine function is the interval $-1 \leq y \leq 1$.

Ratio Test: Provides a sufficient condition for the convergence of a positive series. [113]

reciprocal of a complex number is another complex number, meaning that it has a real part and an imaginary part. To see the parts, multiply and divide by the conjugate of the denominator: $\frac{1}{a + bi} = \frac{a - bi}{(a + bi)(a - bi)} = \frac{a - bi}{a^2 + b^2} = \frac{a}{a^2 + b^2} - \frac{b}{a^2 + b^2}i$

rectangular form of a complex number: The standard $x + yi$ form. [4]

recursion: This is a method of describing a sequence, whereby each term is defined by referring to previous terms. Two examples of recursion are $x_n = 1.007x_{n-1} - 87.17$ [1,6] and $x_n = (1 + x_{n-1})/x_{n-2}$ [24]. To complete such a definition, initial values must be provided.

reduction formula: Recursively generates a sequence of integrals or antiderivatives. [99]

relative maximum means the same thing as *local maximum*.

relative minimum means the same thing as *local minimum*.

Riemann sum: This has the form $f(x_1)w_1 + f(x_2)w_2 + f(x_3)w_3 + \cdots + f(x_n)w_n$. It is an approximation to the integral $\int_a^b f(x) dx$. The interval of integration $a \leq x \leq b$ is divided into subintervals I_1, I_2, I_3, \dots , and I_n , whose lengths are w_1, w_2, w_3, \dots , and w_n , respectively. For each subinterval I_k , the value $f(x_k)$ is calculated using a value x_k from I_k . [61,65] Bernhard Riemann (1826-1866) applied calculus to geometry in original ways.

Mathematics 4C Reference

Rolle's Theorem: If f is a differentiable function, and $f(a) = 0 = f(b)$, then $f'(c) = 0$ for at least one c between a and b . [79] Michel Rolle (1652-1719) described the emerging calculus as a collection of ingenious fallacies.

root: Another name for *zero*. [13]

Rugby: One of the oldest boarding schools in England, it is probably best known for a game that originated there, and for the clothing worn by the players of that game. [111,121]

secant: The reciprocal of the cosine. [18,53]

secant line: A line that intersects a (nonlinear) graph in two places. [8]

seed value: Another name for the initial term in a recursively defined sequence. [3]

seesaw principle: To balance a seesaw, the sum of the *moments* on one side of the fulcrum must equal the sum of the moments on the other side. [120]

separable: A differential equation that can be written in the form $f(y)\frac{dy}{dx} = g(x)$. [57]

sequence: A list, typically generated according to a pattern, which can be described *explicitly*, as in $u_n = 5280(1.02)^n$, or else *recursively*, as in $u_n = 3.46u_{n-1}(1 - u_{n-1})$, $u_0 = 0.331$. In either case, it is understood that n stands for a nonnegative integer.

series: The *sum* of a sequence.

shells: A method of calculating the volume of a *solid of revolution*, which partitions the solid by a system of nested cylindrical shells (or sleeves) of varying heights and radii. [80]

sigma notation: A concise way of describing a *series*. For examples, the expression $\sum_{n=0}^{24} r^n$ stands for the sum $1 + r + r^2 + \dots + r^{24}$, and the expression $\sum_{n=5}^{17} \frac{n}{24}$ stands for $\frac{5}{24} + \frac{6}{24} + \frac{7}{24} + \dots + \frac{17}{24}$. The sigma is the Greek letter S.

sign function: This is defined for all nonzero values of x by $\text{sgn}(x) = \frac{x}{|x|}$. [22]

simple harmonic motion: A sinusoidal function of time that models the movement of some physical objects, such as weights suspended from springs. [37,52]

Simpson's Method is another name for the parabolic method. [77] Thomas Simpson (1710-1761) was a self-taught genius who wrote a popular algebra book.

sinh: See *hyperbolic functions*.

Mathematics 4C Reference

slope field: To visualize the solution curves for a differential equation $\frac{dy}{dx} = F(x, y)$, plot several short segments to represent the slopes assigned to each point in the xy -plane. [69,224]

slope of a curve at a point: The slope of the tangent line at that point. [9,10]

Snell's Law: Also known as the *Law of Refraction*, this describes the change in direction that occurs when light passes from one medium to another. The ratio of speeds is equal to the ratio of the sines of the angles formed by the rays and lines perpendicular to the interface. [52,57] The Dutch physicist Willebrod Snell (1580-1626) did not tell anyone of this discovery when he made it in 1621.

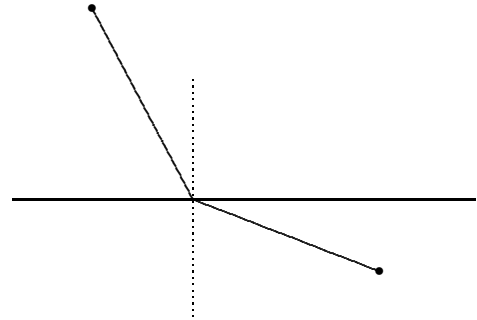

solid of revolution: A 3-dimensional object that is defined by a region \mathcal{R} and a line λ that lie in the same plane: the solid is the union of all circles whose centers are on λ , whose planes are perpendicular to λ , and that intersect \mathcal{R} . [62,72,76,80]

speed: The magnitude of *velocity*. For a parametric curve $(x, y) = (f(t), g(t))$, speed is expressed by the formula $\sqrt{(x')^2 + (y')^2}$, which is sometimes denoted $\frac{ds}{dt}$. [120] Notice that that speed is *not* the same as dy/dx . [26,29,80,81]

standard position: An angle in the xy -plane is said to be in *standard position* if its initial ray points in the positive x -direction. Angles that open in the counterclockwise direction are *positive*; angles that open in the clockwise direction are *negative*.

step function: A piecewise constant function. [46]

surface of revolution: A 2-dimensional object that is defined by an arc \mathcal{A} and a line λ that lie in the same plane: the surface is the union of all circles whose centers are on λ , whose planes are perpendicular to λ , and that intersect \mathcal{A} .

tail: Given an infinite series $a_1 + a_2 + a_3 + \cdots$, a *tail* is the infinite series $a_m + a_{m+1} + \cdots$ that results by removing the partial sum $a_1 + a_2 + \cdots + a_{m-1}$. For the given series to be convergent, the sum of this tail must become arbitrarily small when m is made suitably large; the converse is also true. [112]

tangent line: A line is tangent to a curve at a point P if the line and the curve become indistinguishable when arbitrarily small neighborhoods of P are examined.

tanh: See *hyperbolic functions*.

Mathematics 4C Reference

Taylor polynomial: Given a differentiable function f , a Taylor polynomial $\sum c_n(x-a)^n$ matches all derivatives at $x = a$ through a given order. The coefficient of $(x-a)^n$ is given by Taylor's formula $c_n = \frac{1}{n!}f^{(n)}(a)$. [104] Brook Taylor (1685-1731) wrote books on perspective, and re-invented Taylor series.

Taylor series: A *power series* $\sum c_n(x-a)^n$ in which the coefficients are calculated using Taylor's formula $c_n = \frac{1}{n!}f^{(n)}(a)$. The series is said to be "based at a ." [104,109]

Taylor's Theorem: The difference $f(b) - p_n(b)$ between a function f and its n^{th} Taylor polynomial is $\int_a^b f^{(n+1)}(x) \frac{1}{n!} (b-x)^n dx$. [117]

telescope: Refers to infinite series whose partial sums happen to collapse. [106,109,114]

term-by-term differentiation: The derivative of a sum of functions is the sum of the derivatives of the functions. [34]

Torricelli's Law: When liquid drains from an open container through a hole in the bottom, the speed of the droplets leaving the hole equals the speed that droplets would have if they fell from the liquid surface to the hole. [54,119] Evangelista Torricelli (1608-1647) was the first to consider the graphs of logarithmic functions.

torus: A surface that models an inner tube, or the boundary of a doughnut. [122]

tractrix: A curve traced by an object that is attached to one end of a rope of constant length, and thereby dragged when the other end of the rope moves along a line. [71]

trapezoidal method: A method of numerical integration that approximates the integrand by a piecewise-linear function. [65,66]

triangle inequality: The inequality $PQ \leq PR + RQ$ says that any side of any triangle is at most equal to the sum of the other two sides. [115]

velocity vector: The *velocity vector* of a differentiable curve $(x, y) = (f(t), g(t))$ is $\left[\frac{df}{dt}, \frac{dg}{dt} \right]$ or $\left[\frac{dx}{dt}, \frac{dy}{dt} \right]$, which is tangent to the curve. Its magnitude $\sqrt{\left(\frac{dx}{dt}\right)^2 + \left(\frac{dy}{dt}\right)^2}$ is the speed. Its *components* are derivatives of the component functions. [31,52,80]

volume by cross-sections: See *cross-sections*.

volume by shells: See *shells*.

Mathematics 4C Reference

Wallis product formula is $\frac{\pi}{2} = \frac{2}{1} \cdot \frac{2}{3} \cdot \frac{4}{3} \cdot \frac{4}{5} \cdot \frac{6}{5} \cdot \frac{6}{7} \cdots = \lim_{k \rightarrow \infty} \left(\frac{4^k k! k!}{(2k)!} \right)^2 \frac{1}{2k+1}$. It was published in 1655 by John Wallis (1616-1703), who made original contributions to calculus and geometry.

web diagram: For sequences that are defined recursively in the form $x_n = f(x_{n-1})$, the long-term behavior of the sequence can be visualized by overlaying a web diagram on the graph of $y = f(x)$. [3]

weighted average: A sum $p_1 y_1 + p_2 y_2 + p_3 y_3 + \cdots + p_n y_n$ is called a *weighted average* of the numbers $y_1, y_2, y_3, \dots, y_n$, provided that $p_1 + p_2 + p_3 + \cdots + p_n = 1$ and each *weight* p_k is nonnegative. If $p_k = \frac{1}{n}$ for every k , this average is called the *arithmetic mean*.

Zeno's paradox: In the 5th century BCE, Zeno of Elea argued that motion is impossible, because the moving object cannot reach its destination without first attaining the halfway point. Motion becomes an infinite sequence of tasks, which apparently cannot be completed. To resolve the paradox, observe that the sequence of times needed to accomplish the sequence of tasks is convergent. [106]

zero: A number that produces 0 as a functional value. For example, $\sqrt{2}$ is one of the zeros of the function $f(x) = x^2 - 2$. Notice that 1 is a zero of any logarithm function, because $\log 1$ is 0, and the sine and tangent functions both have 0 as a zero. [8]

Mathematics 4C Reference

Selected Derivative Formulas

1. $D_x au = a \cdot D_x u$ (a is constant)

2. $D_x uv = u \cdot D_x v + v \cdot D_x u$

3. $D_x \frac{u}{v} = \frac{v \cdot D_x u - u \cdot D_x v}{v^2}$

4. $D_x u^n = nu^{n-1} \cdot D_x u$

5. $D_x \ln u = \frac{1}{u} \cdot D_x u$

6. $D_x \log_a u = (\log_a e) \frac{1}{u} \cdot D_x u$

7. $D_x e^u = e^u \cdot D_x u$

8. $D_x a^u = (\ln a)a^u \cdot D_x u$

9. $D_x \sin u = \cos u \cdot D_x u$

10. $D_x \cos u = -\sin u \cdot D_x u$

11. $D_x \tan u = \sec^2 u \cdot D_x u$

12. $D_x \cot u = -\csc^2 u \cdot D_x u$

13. $D_x \sec u = \sec u \tan u \cdot D_x u$

14. $D_x \csc u = -\csc u \cot u \cdot D_x u$

15. $D_x \sin^{-1} u = \frac{1}{\sqrt{1-u^2}} \cdot D_x u$

16. $D_x \arcsin u = \frac{1}{\sqrt{1-u^2}} \cdot D_x u$

17. $D_x \cos^{-1} u = -\frac{1}{\sqrt{1-u^2}} \cdot D_x u$

18. $D_x \arccos u = -\frac{1}{\sqrt{1-u^2}} \cdot D_x u$

19. $D_x \tan^{-1} u = \frac{1}{1+u^2} \cdot D_x u$

20. $D_x \arctan u = \frac{1}{1+u^2} \cdot D_x u$

21. $D_x f(u) = D_u f(u) \cdot D_x u$

22. $D_x u^v = vu^{v-1} \cdot D_x u + u^v \ln u \cdot D_x v$

Mathematics 4C Reference

Selected Antiderivative Formulas

$$1. \int u^n du = \frac{1}{n+1} u^{n+1} + C \quad (n \neq -1) \quad 2. \int \frac{1}{u^n} du = \frac{1}{1-n} u^{1-n} + C \quad (n \neq 1)$$

$$3. \int \frac{1}{u} du = \ln |u| + C$$

$$4. \int a^u du = \frac{1}{\ln a} a^u + C$$

$$5. \int e^u du = e^u + C$$

$$6. \int \ln u du = u \ln u - u + C$$

$$7. \int \sin u du = -\cos u + C$$

$$8. \int \cos u du = \sin u + C$$

$$9. \int \tan u du = \ln |\sec u| + C$$

$$10. \int \cot u du = \ln |\sin u| + C$$

$$11. \int \sec u du = \ln |\sec u + \tan u| + C$$

$$12. \int \csc u du = \ln \left| \tan \frac{u}{2} \right| + C$$

$$13. \int \sec u du = \frac{1}{2} \ln \left| \frac{1 + \sin u}{1 - \sin u} \right| + C$$

$$14. \int \csc u du = -\frac{1}{2} \ln \left| \frac{1 + \cos u}{1 - \cos u} \right| + C$$

$$15. \int \frac{1}{u^2 + a^2} du = \frac{1}{a} \arctan \frac{u}{a} + C \quad (a \neq 0)$$

$$16. \int \frac{1}{u^2 - a^2} du = \frac{1}{2a} \ln \left| \frac{u - a}{u + a} \right| + C \quad (a \neq 0)$$

$$17. \int \frac{mu + b}{u^2 + a^2} du = \frac{m}{2} \ln |u^2 + a^2| + \frac{b}{a} \arctan \frac{u}{a} + C \quad (a \neq 0)$$

$$18. \int \frac{1}{(u - a)(u - b)} du = \frac{1}{a - b} \ln \left| \frac{u - a}{u - b} \right| + C \quad (a \neq b)$$

$$19. \int \frac{mu + k}{(u - a)(u - b)} du = \frac{m}{a - b} \ln \frac{|u - a|^a}{|u - b|^b} + \frac{k}{a - b} \ln \left| \frac{u - a}{u - b} \right| + C \quad (a \neq b)$$

$$20. \int \frac{1}{\sqrt{a^2 - u^2}} du = \arcsin \frac{u}{a} + C \quad (a \neq 0)$$

Mathematics 4C Reference

21. $\int \frac{1}{\sqrt{u^2 - a^2}} du = \ln \left| u + \sqrt{u^2 - a^2} \right| + C$
22. $\int \frac{1}{\sqrt{u^2 + a^2}} du = \ln \left| u + \sqrt{u^2 + a^2} \right| + C$
23. $\int \sqrt{a^2 - u^2} du = \frac{1}{2} u \sqrt{a^2 - u^2} + \frac{a^2}{2} \arcsin \frac{u}{a} + C \quad (a \neq 0)$
24. $\int \sqrt{u^2 - a^2} du = \frac{1}{2} u \sqrt{u^2 - a^2} - \frac{a^2}{2} \ln \left| u + \sqrt{u^2 - a^2} \right| + C \quad (a \neq 0)$
25. $\int \sqrt{u^2 + a^2} du = \frac{1}{2} u \sqrt{u^2 + a^2} + \frac{a^2}{2} \ln \left| u + \sqrt{u^2 + a^2} \right| + C$
26. $\int \frac{1}{u^3 + a^3} du = \frac{1}{a^2} \left(\frac{1}{6} \ln \left| \frac{(u+a)^3}{u^3 + a^3} \right| + \frac{1}{\sqrt{3}} \arctan \frac{2u-a}{a\sqrt{3}} \right) + C \quad (a \neq 0)$
27. $\int e^{au} \sin bu du = \frac{1}{a^2 + b^2} e^{au} (a \sin bu - b \cos bu) + C$
28. $\int e^{au} \cos bu du = \frac{1}{a^2 + b^2} e^{au} (a \cos bu + b \sin bu) + C$
29. $\int \sin au \sin bu du = \frac{1}{b^2 - a^2} (a \cos au \sin bu - b \sin au \cos bu) + C \quad (a^2 \neq b^2)$
30. $\int \cos au \cos bu du = \frac{1}{b^2 - a^2} (b \cos au \sin bu - a \sin au \cos bu) + C \quad (a^2 \neq b^2)$
31. $\int \sin au \cos bu du = \frac{1}{b^2 - a^2} (b \sin au \sin bu + a \cos au \cos bu) + C \quad (a^2 \neq b^2)$
32. $\int u^n \ln u du = \frac{1}{n+1} u^{n+1} \ln |u| - \frac{1}{(n+1)^2} u^{n+1} + C \quad (n \neq -1)$
33. $\int \sin^n u du = -\frac{1}{n} \sin^{n-1} u \cos u + \frac{n-1}{n} \int \sin^{n-2} u du + C \quad (1 < n)$
34. $\int \cos^n u du = \frac{1}{n} \cos^{n-1} u \sin u + \frac{n-1}{n} \int \cos^{n-2} u du + C \quad (1 < n)$

Mathematics 4C Reference

The Circular-Hyperbolic Analogy

$$x^2 + y^2 = 1$$

$$x^2 - y^2 = 1$$

$$x = \cos t \quad y = \sin t$$

$$x = \cosh t \quad y = \sinh t$$

$$\cos^2 t + \sin^2 t = 1$$

$$\cosh^2 t - \sinh^2 t = 1$$

$$\cos(t + u) = \cos t \cos u - \sin t \sin u$$

$$\cosh(t + u) = \cosh t \cosh u + \sinh t \sinh u$$

$$\sin(t + u) = \sin t \cos u + \cos t \sin u$$

$$\sinh(t + u) = \sinh t \cosh u + \cosh t \sinh u$$

$$\sin 2t = 2 \sin t \cos t$$

$$\sinh 2t = 2 \sinh t \cosh t$$

$$\cos 2t = \cos^2 t - \sin^2 t$$

$$\cosh 2t = \cosh^2 t + \sinh^2 t$$

$$\frac{d}{dt} \cos t = -\sin t$$

$$\frac{d}{dt} \cosh t = \sinh t$$

$$\frac{d}{dt} \sin t = \cos t$$

$$\frac{d}{dt} \sinh t = \cosh t$$

$$\frac{d}{dt} \tan t = \frac{1}{\cos^2 t} = \sec^2 t$$

$$\frac{d}{dt} \tanh t = \frac{1}{\cosh^2 t} = \operatorname{sech}^2 t$$

$$\frac{d}{dt} \sec t = \sec t \tan t$$

$$\frac{d}{dt} \operatorname{sech} t = -\operatorname{sech} t \tanh t$$

$$\frac{d}{dt} \csc t = -\csc t \cot t$$

$$\frac{d}{dt} \operatorname{csch} t = -\operatorname{csch} t \coth t$$

$$\frac{d}{dt} \cot t = -\frac{1}{\sin^2 t} = -\operatorname{csc}^2 t$$

$$\frac{d}{dt} \operatorname{coth} t = -\frac{1}{\sinh^2 t} = -\operatorname{csch}^2 t$$

$$\frac{d}{dt} \cos^{-1} t = \frac{-1}{\sqrt{1-t^2}} \quad (-1 < t < 1)$$

$$\frac{d}{dt} \cosh^{-1} t = \frac{1}{\sqrt{t^2-1}} \quad (1 < t)$$

$$\frac{d}{dt} \sin^{-1} t = \frac{1}{\sqrt{1-t^2}} \quad (-1 < t < 1)$$

$$\frac{d}{dt} \sinh^{-1} t = \frac{1}{\sqrt{t^2+1}}$$

$$\frac{d}{dt} \tan^{-1} t = \frac{1}{1+t^2}$$

$$\frac{d}{dt} \tanh^{-1} t = \frac{1}{1-t^2} \quad (-1 < t < 1)$$

Mathematics 4C Reference

Integration by parts

The familiar *product rule* for differentiation is $[f \cdot g]' = f \cdot g' + g \cdot f'$. Integrate this from $x = a$ to $x = b$ to obtain $\int_a^b [f \cdot g]'(x) dx = \int_a^b f(x)g'(x) dx + \int_a^b g(x)f'(x) dx$. Apply the Fundamental Theorem of calculus to the first integral. The result is

$$f(b)g(b) - f(a)g(a) = \int_a^b f(x)g'(x) dx + \int_a^b g(x)f'(x) dx,$$

which is known as the *integration by parts formula*. The functions f and g are the *parts*. The usefulness of this formula is that *either of the two integrals that appear in it can be evaluated if the other can be*. Here are some examples:

1. To treat $\int_1^e x \ln x dx$ by this method, use the parts $f(x) = \frac{1}{2}x^2$ and $g(x) = \ln x$. These were chosen so that $f'(x)g(x) = x \ln x$. Notice that $f(x)g'(x) = \frac{1}{2}x$. The parts formula says that $\frac{1}{2}e^2 - 0 = \int_1^e \frac{1}{2}x dx + \int_1^e x \ln x dx$. It follows that $\frac{1}{4}(e^2 + 1) = \int_1^e x \ln x dx$.

2. It is perhaps surprising that $\int_0^1 \arctan x dx$ can be treated by this method. Use the parts $f(x) = x$ and $g(x) = \arctan x$. Notice that $f'(x)g(x) = \arctan x$ and $f(x)g'(x) = \frac{x}{1+x^2}$.

The parts formula says that $\frac{1}{4}\pi - 0 = \int_0^1 x(1+x^2)^{-1} dx + \int_0^1 \arctan x dx$, hence it follows that $\frac{1}{4}\pi - \frac{1}{2}\ln 2 = \int_0^1 \arctan x dx$.

3. The integral $\int_0^1 x^2 e^x dx$ requires more than one application of the parts method. First let $f(x) = x^2$ and $g(x) = e^x$. These parts were chosen so that $f(x)g'(x) = x^2 e^x$. Notice that $g(x)f'(x) = 2xe^x$. It follows from the parts formula that $e - \int_0^1 2xe^x dx = \int_0^1 x^2 e^x dx$. It is still necessary to treat $\int_0^1 2xe^x dx$, so use the parts $f(x) = 2x$ and $g(x) = e^x$. The parts formula yields $2e - \int_0^1 2e^x dx = \int_0^1 2xe^x dx$. It follows that $e - 2 = \int_0^1 x^2 e^x dx$.

4. To solve the integral $\int_0^{\pi/2} \cos^5 x dx$, choose the parts $f(x) = \sin x$ and $g(x) = \cos^4 x$, and notice that $g(x)f'(x) = \cos^5 x$ and $f(x)g'(x) = -4\sin^2 x \cos^3 x$. The parts formula says that $0 - 0 = \int_0^{\pi/2} \cos^5 x dx - \int_0^{\pi/2} 4\sin^2 x \cos^3 x dx$, so the requested $\int_0^{\pi/2} \cos^5 x dx$ has the same value as $\int_0^{\pi/2} 4\sin^2 x \cos^3 x dx$. It is now helpful to replace $\sin^2 x$ by $1 - \cos^2 x$, which converts $\int_0^{\pi/2} \cos^5 x dx = \int_0^{\pi/2} 4\sin^2 x \cos^3 x dx$ into $5 \int_0^{\pi/2} \cos^5 x dx = 4 \int_0^{\pi/2} \cos^3 x dx$. Once you find a way to show that $\frac{2}{3} = \int_0^{\pi/2} \cos^3 x dx$, you will then understand why $\frac{8}{15} = \int_0^{\pi/2} \cos^5 x dx$.

Mathematics 4C Reference

Integration by substitution

1. It is not clear by inspection whether the integral $\int_1^8 \frac{1}{x + x^{2/3}} dx$ can be evaluated by means of antidifferentiation (the Fundamental Theorem of Calculus). One approach to this difficulty is to apply the *substitution method*, with the hope of creating an equivalent and recognizable definite integral. The integration variable x is to be replaced by a function of some new variable, *everywhere* that x appears in the integral. There are three places to look — the *integrand*, the *limits of integration*, and the *differential*.

In this example, the integrand suggests that replacing x by t^3 might be beneficial, for this will eliminate the fractional exponent. Confirm the following calculations:

$$\int_{x=1}^{x=8} \frac{1}{x + x^{2/3}} dx = \int_{t^3=1}^{t^3=8} \frac{1}{t^3 + t^2} 3t^2 dt = \int_{t=1}^{t=2} \frac{3t^2}{t^3 + t^2} dt = \int_1^2 \frac{3}{t+1} dt$$

Because $3 \ln(1+t)$ is an antiderivative for the integrand on the right, it is now straightforward to verify that $3 \ln \frac{3}{2} = 1.216 \dots$ is the common value of all these integrals.

Notice the role of the Chain Rule in replacing dx by the equivalent $3t^2 dt$. This essential step explains why you should never forget to write the differential when composing (or copying) an integral: *If the differential does not appear in an integral, it is likely to be overlooked when making a substitution.*

The figure at right, which graphs the x -substitution as a function of t , shows that it would also be a mistake to assume that the differentials dx and dt are interchangeable.

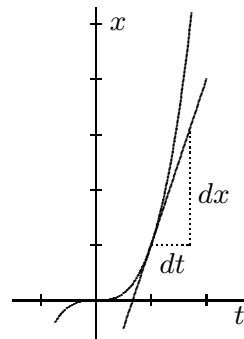

2. The substitution method is often applied to examples in which it is difficult — perhaps even impossible — to explicitly express x as a function of the new integration variable. What makes these examples manageable is that the substitution is chosen *implicitly* to take advantage of a conspicuous Chain-Rule shortcut. For example, consider $\int_{\pi/2}^{\pi} \frac{1 + \cos x}{x + \sin x} dx$. Solving the equation $t = x + \sin x$ for x as a function of t is out of the question, but it does not matter, because it so happens that $\frac{dt}{dx} = 1 + \cos x$, allowing $(1 + \cos x) dx$ to be replaced by just dt . The integration limits for the new integral are given explicitly by $t = x + \sin x$, thus

$$\int_{x=\pi/2}^{x=\pi} \frac{1 + \cos x}{x + \sin x} dx = \int_{t=1+\frac{1}{2}\pi}^{t=\pi} \frac{1}{t} dt = \ln t \Big|_{1+\frac{1}{2}\pi}^{\pi} = \ln \pi - \ln \left(1 + \frac{1}{2} \pi\right) = \ln \frac{2\pi}{2 + \pi}$$

Mathematics 4C Reference

Limit Definitions and Theorems

In the sequel, it is understood that L and M are real numbers.

- 1. Definition.** Let x_1, x_2, \dots be an infinite sequence of real numbers. The sequence is said to *converge to L* provided that: for every $\epsilon > 0$ there is an integer N (which depends on ϵ), such that $|x_n - L| < \epsilon$ is true whenever $N < n$.
- 2. Definition.** Let S be a nonempty set of real numbers, and p and q be real numbers. If $p \leq x$ for every x in S , then p is called a *lower bound* for S , and S is said to be *bounded below*. If $x \leq q$ for every x in S , then q is called an *upper bound* for S , and S is said to be *bounded above*. If S has both a lower bound and an upper bound, then it is customary to say simply that S is *bounded*.
- 3. Definition.** Let p be a lower bound for a nonempty set S of real numbers. If every other lower bound b for S satisfies $b < p$, then p is called the *greatest lower bound* of S . The terminology *least upper bound* is defined in a similar fashion.
- 4. Theorem.** Let S be a nonempty set of real numbers. If S is bounded below, then it has a greatest lower bound. If S is bounded above, then it has a least upper bound.
- 5. Theorem.** If a sequence of real numbers is monotonically increasing and bounded above, then it converges. If a sequence of real numbers is monotonically decreasing and bounded below, then it converges.
- 6. Theorem.** Given sequences $\{x_n\}$ and $\{y_n\}$ that converge to L and M , respectively,
 - (a) the sequence $\{x_n + y_n\}$ converges to $L + M$;
 - (b) the sequence $\{x_n - y_n\}$ converges to $L - M$;
 - (c) the sequence $\{x_n y_n\}$ converges to LM ;
 - (d) if $M \neq 0$, the sequence $\{x_n/y_n\}$ converges to L/M .
- 7. Definition.** Let $x_1 + x_2 + \dots = \sum_{i=1}^{\infty} x_i$ be an infinite series of real numbers. The series is said to *converge to L* provided that: for every $\epsilon > 0$ there is a number N (which depends on ϵ), such that $|L - \sum_{i=1}^n x_i| < \epsilon$ is true whenever $N < n$.
- 8. Theorem.** Given series $\sum_{i=1}^{\infty} x_i$ and $\sum_{i=1}^{\infty} y_i$ that converge to L and M , respectively,
 - (a) the series $\sum_{i=1}^{\infty} (x_i + y_i)$ converges to $L + M$;
 - (b) the series $\sum_{i=1}^{\infty} (x_i - y_i)$ converges to $L - M$.
- 9. Definition.** An infinite sequence x_1, x_2, \dots of real numbers is said to be a *Cauchy sequence* provided that: for every $\epsilon > 0$ there is an integer N (which depends on ϵ), such that $|x_n - x_m| < \epsilon$ is true whenever $N < n$ and $N < m$.
- 10. Theorem.** A sequence converges if and only if it is a Cauchy sequence.

Mathematics 4C Reference

11. Definition. Suppose that $f(x)$ is defined for all x in an interval that includes a , except possibly at a itself. The function is said to *approach L as x approaches a* , written $\lim_{x \rightarrow a} f(x) = L$, provided that: for every $\epsilon > 0$ there is a $\delta > 0$ (which depends on ϵ), such that $|f(x) - L| < \epsilon$ is true whenever $0 < |x - a| < \delta$.

12. Theorem. Given that $\lim_{x \rightarrow a} f(x) = L$ and $\lim_{x \rightarrow a} g(x) = M$, then

- (a) $\lim_{x \rightarrow a} (f(x) + g(x)) = L + M$; (b) $\lim_{x \rightarrow a} (f(x) - g(x)) = L - M$;
(c) $\lim_{x \rightarrow a} f(x)g(x) = LM$; (d) if $M \neq 0$, $\lim_{x \rightarrow a} f(x)/g(x) = L/M$.

13. Definition. Suppose that $f(x)$ is defined for all x in an interval that includes a . Then f is said to be *continuous at a* , provided that $f(a) = \lim_{x \rightarrow a} f(x)$. If f is continuous at every point in its domain, it is called *continuous*.

14. Theorem. Given that f and g are both continuous at a , then the functions $f + g$, $f - g$, and $f \cdot g$ are also continuous at a ; if $g(a) \neq 0$, then the function f/g is continuous at a .

15. Theorem. If $\lim_{x \rightarrow a} g(x) = b$ and $\lim_{x \rightarrow b} f(x) = L$, then $\lim_{x \rightarrow a} f(g(x)) = L$.

16. Theorem. Suppose that g is continuous at a , and that f is continuous at $g(a)$. Let h be the *composite function* defined by $h(x) = f(g(x))$. Then h is continuous at a .

17. Definition. Suppose that $f(x)$ is defined for all x in an interval that includes a . Then f is said to be *differentiable at a* , provided that $\lim_{x \rightarrow a} (f(x) - f(a))/(x - a)$ exists.

18. Definition. Suppose that $f(x)$ is defined for all x in an interval that includes a , except possibly at a itself. The function is said to *approach ∞ as x approaches a* , written $\lim_{x \rightarrow a} f(x) = \infty$, provided that: for every M there is a $\delta > 0$ (which depends on M), such that $M < f(x)$ is true whenever $0 < |x - a| < \delta$.

19. Definition. Suppose that $f(x)$ is defined for all x in an interval that includes a , except possibly at a itself. The function is said to *approach $-\infty$ as x approaches a* , written $\lim_{x \rightarrow a} f(x) = -\infty$, provided that: for every M there is a $\delta > 0$ (which depends on M), such that $f(x) < M$ is true whenever $0 < |x - a| < \delta$.

Mathematics 4C Reference

Slope fields using Winplot

Start *Winplot* by double-clicking its icon, found in the folder *Applications|Peanut*. Click **Window|2-dim** (or just press the *F2* key) to open a graphing window.

To work on an example, open the **Differential|dy/dx** dialog box in the pull-down **Equa** menu. If you want to explore the equation $\frac{dy}{dx} = 2xy$, just type $2xy$ into the edit box. In order to see slope fields, the **slopes** radio button should be checked. You can change the number of *horizontal rows*, which defaults to 20, but it will probably not be necessary. You can also change the *lengths* of the little segments that the program draws. The default length is about 1.5% of the width of the computer screen, which will seem too long if your drawing window is small. You can also change the **color** of the slopes, which defaults to black. When all the information is ready, click **ok**. A slope field should appear, along with an inventory dialog box that shows the example you entered. If you want to edit any of the information, select the example in the inventory list box and click **Edit**.

Once an example has appeared on the screen, you may wish to alter the viewframe. Pull down the **View** menu and consider the options. The simplest alterations are to zoom out (press *PgDn*) or zoom in (press *PgUp*). Setting the window more precisely requires the **View|View** dialog (press *Ctrl+V*). This allows you to set the center and width of the viewframe, or to define the corners of the viewframe (unlinking the scale on the two axes).

By the way, to see solution curves, you must open the **One|dy/dx trajectory** dialog. This allows you to initiate a trajectory by using the mouse (a left-click in the drawing window will produce the solution curve that goes through the clicked point) or by typing in the coordinates of the initial point of the desired trajectory and clicking **draw**. All solution curves are saved in an inventory.

To print a copy of the window, click **File|Print**, but first use the **File|Format** dialog to position the output on the paper. For more information, click **File|Help**.

Implicitly defined curves using Winplot

As above, start the program, and click **Window|2-dim** to obtain a graphing window.

Open the **Implicit** dialog box in the pull-down **Equa** menu, and type the desired equation into the edit box. Notice that the default equation $x^2 + y^2 = 13$ defines a circle of radius $\sqrt{13}$. The program does not know how many connected pieces the finished graph will consist of, and it may stop looking before it has found them all. For instance, the graph of $0.28 = \sin x \sin y$ has infinitely many components. You can instruct the computer to keep looking by checking the **long search** box before clicking **ok**, but be advised: The computer keeps looking until you press *Q*. For more information, click **Equa|Help**.

Printing and changing viewframes is accomplished as described above.

Mathematics 4C Reference

